

## **Step-Down WLED-Current Controller with Wide 6V to 60V Input Voltage**

### **❖ GENERAL DESCRIPTION**

The AX2024 is a high-efficiency step-down controller. It is designed to operate in continuous current mode (CCM) to power LEDs of high-brightness with a wide input voltage range of 6V to 60V.

The AX2024 employs a hysteretic control architecture that accurately regulates LED current with a feedback coming from an external high-side current-sense resistor. This control scheme optimizes circuit stabilization and fast response time without loop compensation. Its low 200mV average feedback voltage reduces power loss and improves the converter's efficiency.

The AX2024 implements PWM and analog dimming together through the EN/DIM pin.

The AX2024 includes thermal overload protection in case of output overload.

The AX2024 is available in TSOT-23-6L package.

### **❖ FEATURES**

- Wide 6V to 60V Input Range
- Able to Drive >1A LED Load
- Hysteresis Control
- High Efficiency (>95%)
- 2500:1 PWM Dimming Ratio
- Open LED Protection
- Short LED Protection
- Thermal Shutdown
- RoHS and Halogen free compliance.

### **❖ APPLICATIONS**

- Low Voltage Halogen Replacement
- Low Voltage General Illumination
- Automotive/Decorative LED Lighting
- Signs/Emergency Lighting
- LED Backlighting

### ❖ TYPICAL APPLICATION

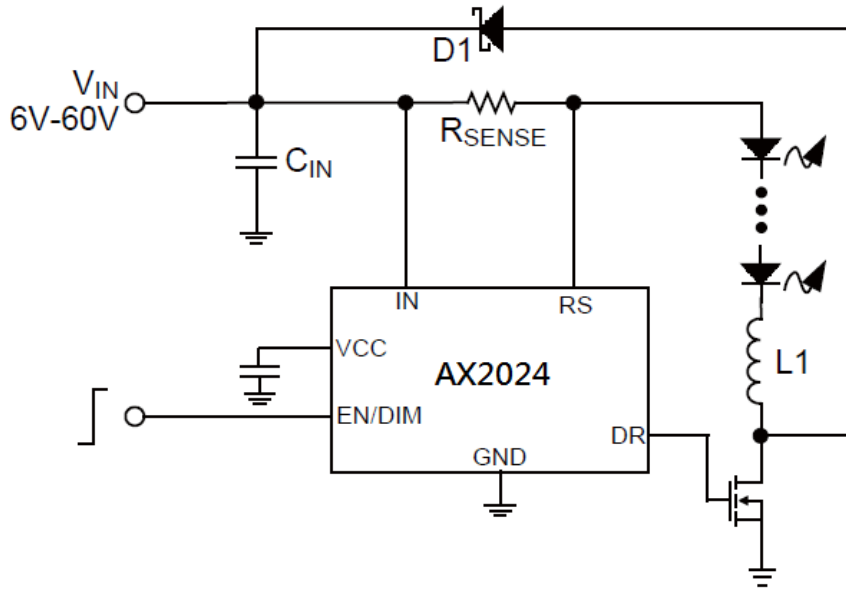

### ❖ PIN ASSIGNMENT

The package of AX2024 is TSOT-23-6L; the pin assignment is given by:

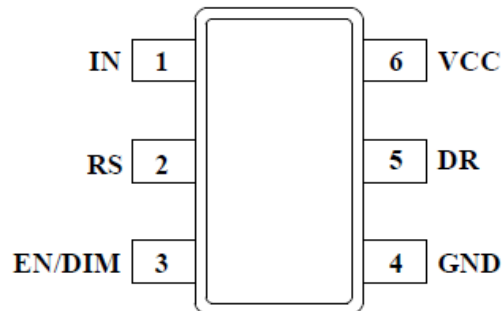

### ❖ PIN FUNCTIONS

| Pin # | Name   | Description  |
|-------|--------|--|
| 1     | IN     | Input Supply Pin. Connect a decoupling capacitor from IN pin to GND.   |
| 2     | RS     | LED Current Sense Input. Connect a current-sense resistor that programs LED average current to the IN pin.   |
| 3     | EN/DIM | Enable/Dimming Command Input. A voltage greater than 0.3V turns on the chip. To use PWM dimming, apply a square wave signal to this pin. If dimming-off time is larger than 20ms, the IC shuts down. For analog dimming, the EN/DIM pin voltage rises from 0.3V to 2.7V and LED current will change from 20% to 100% of the maximum LED current. |
| 4     | GND    | Ground.  |
| 5     | DR     | Gate-Driver Output. Connect this pin to the gate of the external MOSFET.   |
| 6     | VCC    | Internal Regulator Output. Connect a 1µF decoupling cap from this pin to ground.   |



**❖ ELECTRICAL CHARACTERISTICS**

 ( $V_{IN} = 24V$ ,  $T_A = 25^{\circ}C$ , unless otherwise noted.)

| Parameter  | Symbol          | Condition             | Min | Typ      | Max  | Units       |
|--|-----------------|-----------------------|-----|----------|------|-------------|
| Input voltage  | $V_{IN}$        |                       | 6   |          | 60   | V           |
| Shutdown supply current                              | $I_{SD}$        |                       |     | 80       | 108  | $\mu A$     |
| Quiescent supply current                             | $I_Q$           | No Switching          |     | 0.3      | 0.5  | mA          |
| VCC voltage  | VCC             | $V_{EN/DIM} = 3.5V$   | 5.5 | 6        |      | V           |
| Feedback average voltage (with respect to $V_{IN}$ ) | $V_{IN}-V_{RS}$ | $V_{EN/DIM} = 3.5V$   | 194 | 200      | 206  | mV          |
| Feedback reference voltage hysteresis                | $V_{FB\_HYS}$   |                       |     | $\pm 30$ |      | mV          |
| EN/DIM enable high voltage                           | $V_{EN\_HIGH}$  | $V_{EN}$ Rising       |     | 0.29     | 0.34 | V           |
| EN/DIM enable hysteresis                             | $V_{EN\_HYS}$   |                       | 20  | 50       | 80   | mV          |
| EN/DIM pull-up current                               |                 | Pull up to 5V         |     | 2.8      |      | $\mu A$     |
| EN/DIM pull-down current                             |                 | Pull down to GND      |     | 25       |      | $\mu A$     |
| Min recommended pwm dimming frequency                | $F_{PWMmin}$    |                       |     | 0.1      |      | kHz         |
| Max recommended pwm dimming frequency                | $F_{PWMmax}$    |                       |     | 20       |      | kHz         |
| Gate driver source resistor                          | $R_{source}$    | $V_{GS} = 5.5V$       |     | 6        |      | $\Omega$    |
| Gate driver sink resistor                            | $R_{sink}$      |                       |     | 2        |      | $\Omega$    |
| Gate driver output-voltage high                      | $V_{OH}$        | $I_{DRV} = 10mA$      | 5.5 |          |      | V           |
| Gate driver output-voltage low                       | $V_{OL}$        | $I_{DRV} = 10mA$      |     |          | 0.5  | V           |
| Minimum on time                                      | $T_{ON\_MIN}$   | Guarantee by Designer |     | 100      |      | ns          |
| Minimum off time                                     | $T_{OFF\_MIN}$  | Guarantee by Designer |     | 100      |      | ns          |
| Recommended maximum operating frequency              | $F_{MAX}$       |                       |     | 1        |      | MHz         |
| UVLO threshold voltage(VCC)                          | $V_{UVLOTH}$    | VCC Rising            |     | 5.6      |      | V           |
| UVLO hysteresis                                      | $V_{UVLOHYS}$   |                       |     | 0.4      |      | V           |
| Thermal shutdown threshold                           |                 | Temp Rising           |     | 150      |      | $^{\circ}C$ |
| Thermal shutdown hysteresis                          |                 | Guarantee by Designer |     | 20       |      | $^{\circ}C$ |

❖ FUNCTIONAL BLOCK DIAGRAM

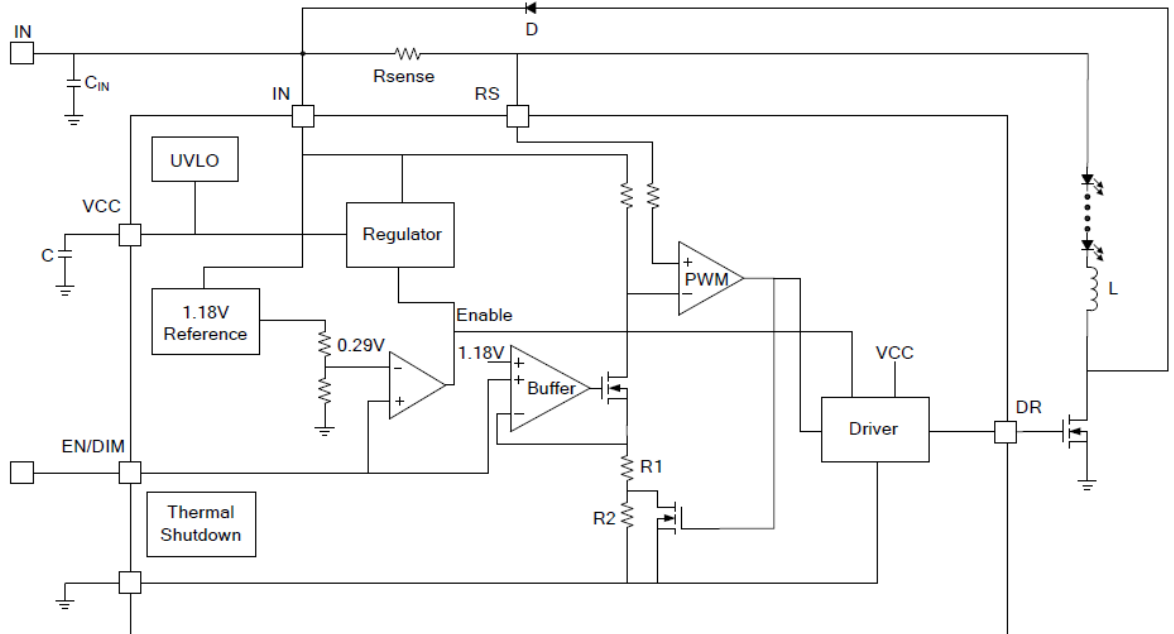

Figure 1—AX2024 Functional Block Diagram

❖ FUNCTION DESCRIPTIONS

Operation

Steady State

The AX2024 is a step-down LED-current controller with hysteresis control that is easily configured for a wide input that ranges from 6V to 60V input. The AX2024 uses a high-side current-sense resistor to detect and regulate LED current. The voltage across the current-sense resistor is measured and regulated in the 200mV±30mV range.

The internal 1.18V reference voltage provides a 0.3V reference to enable the part. When  $V_{EN} > 0.3V$ , the output of the comparator goes high and enables the other blocks. The AX2024 also provides a 5V pull-up voltage as current reference voltage when EN/DIM pin is float.

The inductor current is sensed through the high-side resistor,  $R_{sense}$ . When the switch is on, R2 (see Figure 1) is shorted and inductor current upper-threshold is fixed by R1. When the switch is off, inductor current lower-threshold is fixed by R1 and R2. The ratio of R1 and R2 determines the current hysteresis.

System Soft Start

The voltage on the EN/DIM pin provides the inductor current reference. An external capacitor from the EN/DIM pin to ground provides a soft-start delay. When  $V_{IN}$  starts, internal voltage source charges the capacitor from 0V to 5V to fulfill soft-start function.

### Dimming Control

The AX2024 allows the EN/DIM pin to control both Analog and PWM dimming. Whenever the voltage on DIM is less than 0.25V, the chip turns off. For analog dimming, when the voltage on DIM is from 0.3V to 2.7V, the LED current will change from 20% to 100% of the maximum LED current. If the voltage on EN pin is higher than 2.9V, output LED current will equal the maximum LED current. For PWM dimming, the signal amplitude must exceed 3V. Choose a PWM frequency in range of 100Hz to 20kHz for good dimming linearity.

## ❖ APPLICATION INFORMATION

### Setting the LED Current

The LED current is identical and set by the current sense resistor between the IN pin and RS pin.

$$R_{SENSE} = 200\text{mV}/I_{LED}$$

For  $R_{SENSE} = 0.2\Omega$ , the LED current is set to 1A

### Selecting the Inductor

Lower value of inductance can result in a higher switching frequency, which causes a larger switching loss. Choose a switch frequency between 100kHz to 600kHz for most application. According to switching frequency, inductor value can be estimated as:

$$L = \frac{(1 - \frac{V_{OUT}}{V_{IN}}) \times V_{OUT}}{0.3 \times I_{LED} \times f_{SW}}$$

For higher efficiency, choose an inductor with a DC resistance as small as possible.

### Selecting the Input Capacitor

The input capacitor reduces the surge current drawn from the input supply and the switching noise from the device. Choose a capacitor value between 10 $\mu$ F and 22 $\mu$ F for most applications. The voltage rating should be greater than the input voltage. Use a low ESR capacitor for input decoupling.

### Selecting the Output Capacitor

For most applications, the output capacitor is not necessary. For applications that require that the peak-to-peak LED ripple current falls below 30% of the average current, add a capacitor across the LEDs. Higher capacitor values will result in proportionally lower ripple. A value of 2.2 $\mu$ F will meet most requirements.

### Selecting Soft-Start Capacitor

When selecting a soft-start capacitor, the delay time can be estimated as 0.2ms/nF. For PWM dimming, select  $C < 2.2\text{nF}$  to eliminate its effect on the average LED current.

### Dimming Control

AX2024 provides 1:2500 high-ratio PWM dimming. Apply a 100Hz to 20kHz square waveform to the EN/DIM pin. The average LED current is proportional to PWM duty cycle.

**Layout Consideration**

Pay careful attention to the PCB layout and component placement.  $R_{SENSE}$  should be placed close to the IN pin and RS pin in order to minimize current sense error. The input loop—including input capacitor, Schottky diode, and Mosfet—should be as short as possible.

**Design Example**

Below is a design example following the application guidelines for the specifications:

**Table 1: Design Example**

|                  |     |
|------------------|-----|
| $V_{IN}$         | 24V |
| $V_{OUT}$        | 10V |
| I <sub>out</sub> | 1A  |

The detailed application schematic is shown in Figure 2. The typical performance and circuit waveforms have been shown in the Typical Performance Characteristics section. For more device applications, please refer to the related Evaluation Board Datasheets.

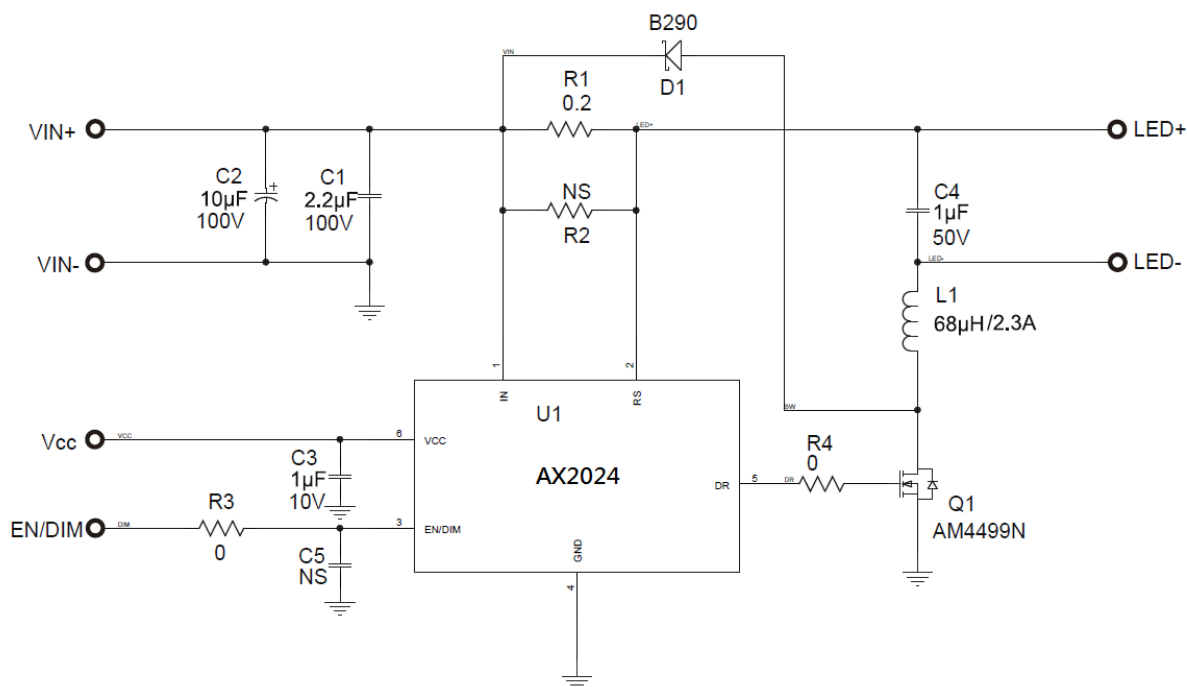

**Figure 2: Application Circuit**

❖ TYPICAL CHARACTERISTICS

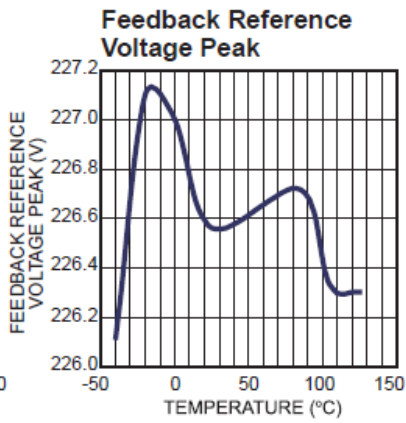
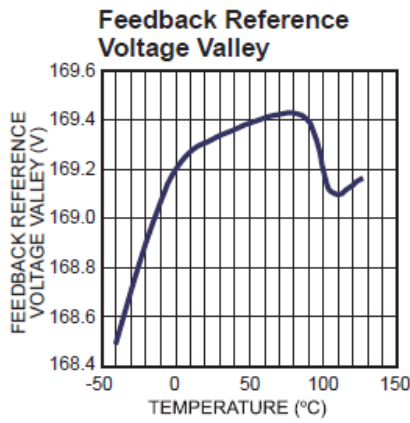
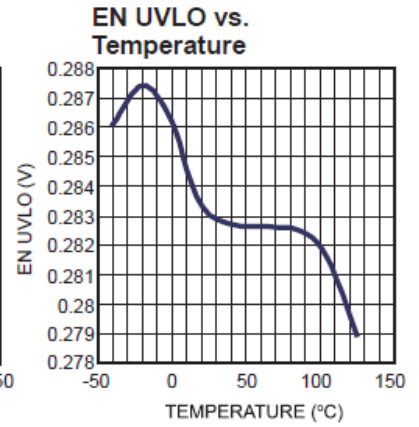
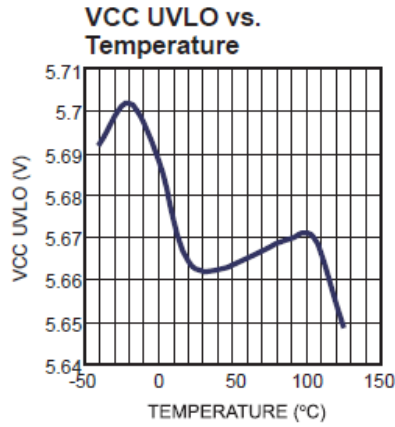
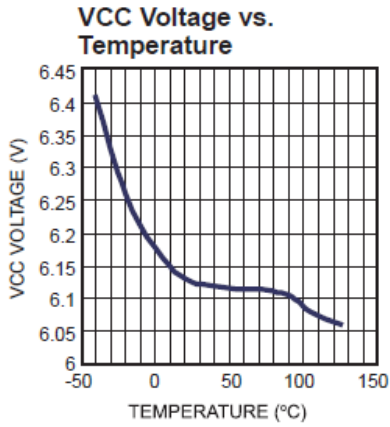



❖ TYPICAL PERFORMANCE CHARACTERISTICS

Performance waveforms are tested on the evaluation board of the Design Example section.  $V_{IN} = 24V$ , 3LEDs,  $I_{OUT} = 1A$ ,  $T_A = 25^\circ C$ , unless otherwise noted.

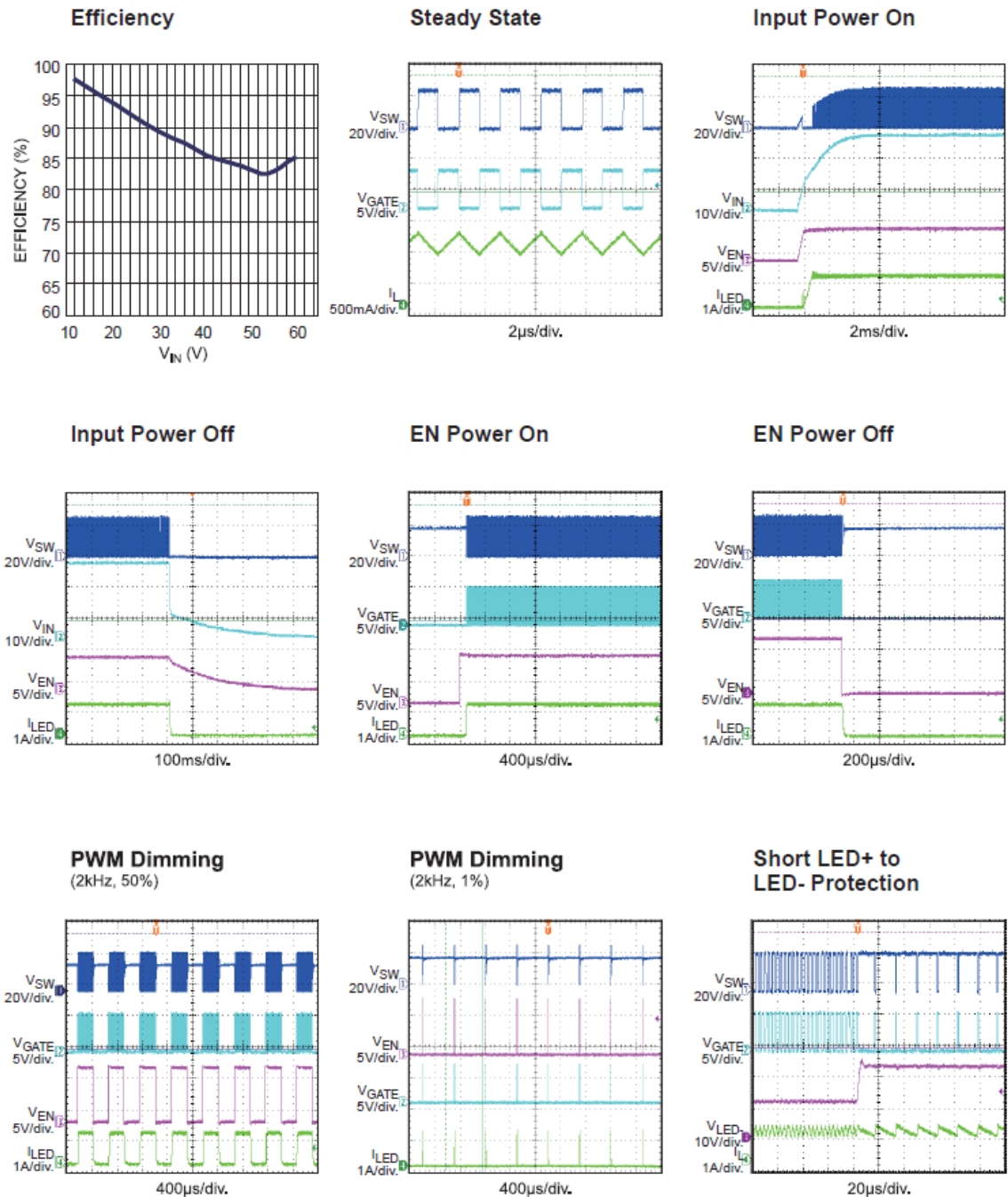

❖ **TYPICAL PERFORMANCE CHARACTERISTICS (continued)**

Performance waveforms are tested on the evaluation board of the Design Example section.  $V_{IN} = 24V$ , 3LEDs,  $I_{OUT} = 1A$ ,  $T_A = 25^{\circ}C$ , unless otherwise noted.

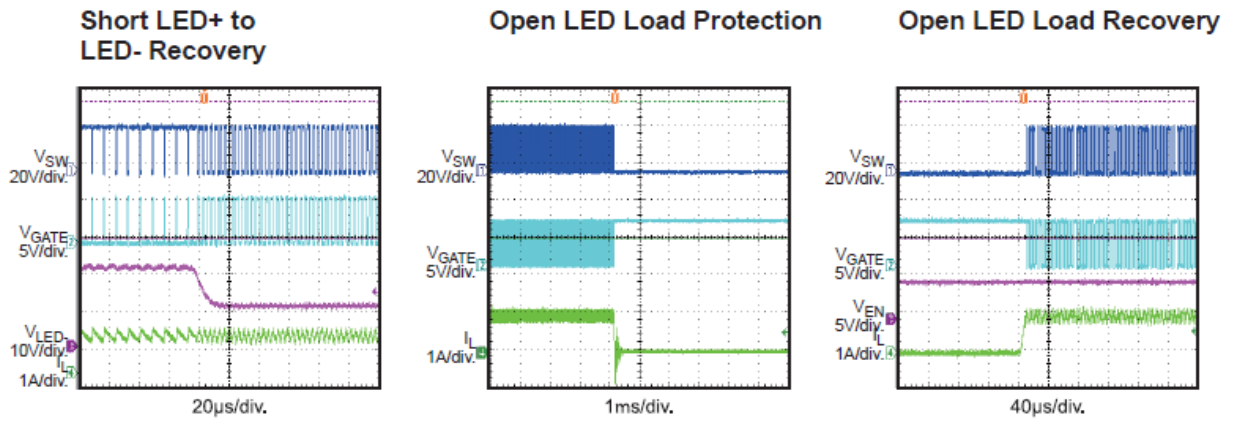

❖ PACKAGE OUTLINES

TSOT-23-6L

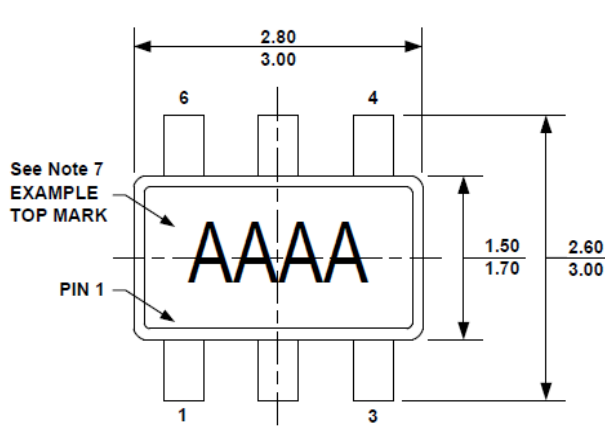

**TOP VIEW**

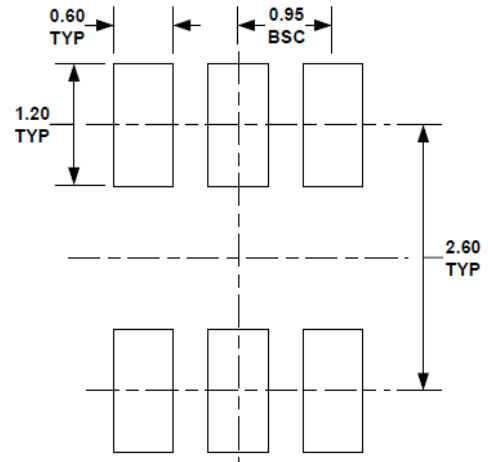

**RECOMMENDED LAND PATTERN**

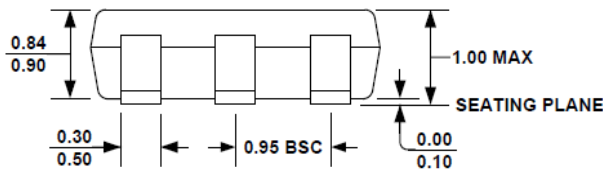

**FRONT VIEW**

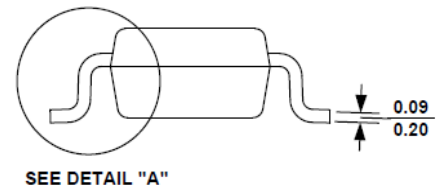

**SIDE VIEW**

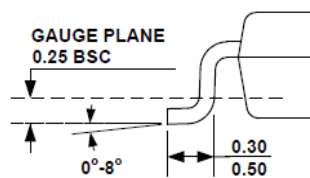

**DETAIL "A"**

**NOTE:**

- 1) ALL DIMENSIONS ARE IN MILLIMETERS.
- 2) PACKAGE LENGTH DOES NOT INCLUDE MOLD FLASH, PROTRUSION OR GATE BURR.
- 3) PACKAGE WIDTH DOES NOT INCLUDE INTERLEAD FLASH OR PROTRUSION.
- 4) LEAD COPLANARITY (BOTTOM OF LEADS AFTER FORMING) SHALL BE 0.10 MILLIMETERS MAX.
- 5) DRAWING CONFORMS TO JEDEC MO-193, VARIATION AB.
- 6) DRAWING IS NOT TO SCALE.
- 7) PIN 1 IS LOWER LEFT PIN WHEN READING TOP MARK FROM LEFT TO RIGHT, (SEE EXAMPLE TOP MARK)