

1.2V Output-1A LOW Dropout Linear Regulator

❖ GENERAL DESCRIPTION

AX1212 is a low dropout positive 1.2V output regulator with minimum of 1A output current capability. The product is specifically designed to provide well-regulated supply for low voltage IC applications. AX1212 is also well suited for other applications such as VGA cards. AX1212 is guaranteed to have lower than 1.4V dropout at full load current making it ideal to provide well-regulated outputs of 1.2V with 2.6V to 12V input supply.

❖ FEATURES

- Fixed 1.2V \pm 2% output voltage
- 1.4V maximum dropout at full load current
- Fast transient response
- Output current limiting
- Built-in thermal shutdown
- Good noise rejection
- Pb-Free Packages: SOT223, TO252

❖ BLOCK DIAGRAM

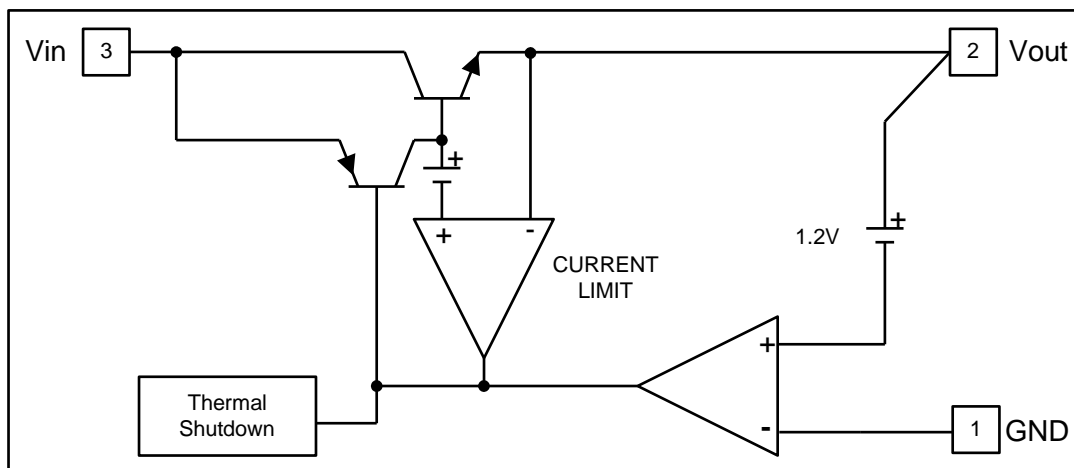

❖ PIN ASSIGNMENT

The packages of AX1212 are SOT223-3L and TO252-3L; the pin assignment is given by:

Name	Description
GND	A resistor divider from this pin to the V _{OUT} pin and ground sets the output voltage. (Ground only for Fixed-Mode)
V _{OUT}	The output of the regulator. A minimum of 10uF capacitor (0.1Ω ≤ ESR ≤ 20Ω) must be connected from this pin to ground to insure stability.
V _{IN}	The input pin of regulator. Typically a large storage capacitor (0.10Ω ≤ ESR ≤ 20Ω) is connected from this pin to ground to insure that the input voltage does not sag below the minimum dropout voltage during the load transient response. This pin must always be 1.4V higher than V _{OUT} in order for the device to regulate properly.

Package	Pin	Function
SOT223 (Top View)	3	V _{IN}
	2	V _{OUT}
	1	GND
Tab is V _{out}		
TO252 (Top View)	3	V _{IN}
	2	V _{OUT}
	1	GND
Tab is V _{out}		

❖ ORDER/MARKING INFORMATION

Order Information	
AX1212 X X	
Low Dropout Regulator	Package E : SOT223-3L D : TO252-3L
	Packing Blank : Tube A : Taping
Top Marking (SOT223-3L)	Top Marking (TO252-3L)
Logo ← AX 1 2 1 2 → Part number YWWX → ID code: internal → WW: 01~52 → Year: A=2010 1=2011	Logo ← AX 1 2 1 2 → Part number YYWWX → ID code: internal → WW: 01~52 → Year: 10=2010 11=2011

❖ ABSOLUTE MAXIMUM RATINGS (T_A = 25°C)

Characteristics	Symbol	Rating	Unit
DC Supply Voltage	V _{in}	-0.3 to 12	V
Operating Junction Temperature Range	T _{OP}	0 to +125	°C
Maximum junction Temperature	T _{MJ}	150	°C
Power Dissipation (multi-layer PCB copper area 10mm*10mm) T _A =25°C, T _J =125°C	SOT-223	1330	mW
	TO-252	1810	
Storage Temperature	T _{ST}	-65 to +150	°C

❖ ELECTRICAL CHARACTERISTICS

(Under Operating Conditions)

Characteristics	Conditions	Min	Typ	Max	Units
Operation Input Voltage		2.6	-	12	V
Output Voltage	$I_{OUT} = 10\text{mA}$, $2.6\text{V} \leq V_{IN} \leq 12\text{V}$, $T_J = 25^\circ\text{C}$	1.175	1.20	1.225	V
Line Regulation	$I_{OUT} = 10\text{mA}$, $2.6\text{V} \leq V_{IN} \leq 7\text{V}$, $T_J = 25^\circ\text{C}$ (Note 1,2)	-	1.2	3.6	mV
	$I_{OUT} = 10\text{mA}$, $2.6\text{V} \leq V_{IN} \leq 12\text{V}$, $T_J = 25^\circ\text{C}$ (Note 1,2)	-	1.8	6	mV
Load Regulation	$V_{IN} = 2.6\text{V}$, $10\text{mA} < I_{O} < 1\text{A}$, $T_J = 25^\circ\text{C}$ (Note 1,2)	-		12	mV
Dropout Voltage ($V_{IN} - V_{OUT}$)	$I_{OUT} = 1\text{A}$, $\Delta V_{OUT} = 1\% V_{OUT}$	-	1.3	1.4	V
Current Limit	$(V_{IN} - V_{OUT}) = 3\text{V}$	1	-	-	A
Minimum Load Current	$0^\circ\text{C} \leq T_J \leq 125^\circ\text{C}$	-	5	10	mA
Ripple Rejection	$F = 120\text{Hz}$, $C_{OUT} = 25\mu\text{F}$ Tantalum, $I_{OUT} = 1\text{A}$, $V_{IN} = 5\text{V}$	-	60	70	dB
Temperature Stability	$I_{OUT} = 10\text{mA}$	-	0.5	-	%
θ_{JA} Thermal Resistance Junction-to-Ambient (Note 4)	SOT-223 TO-252	-	75 55	-	$^\circ\text{C/W}$
θ_{JC} Thermal Resistance Junction-to-Case	SOT-223 TO-252	-	15 10	-	$^\circ\text{C/W}$

Note1: See thermal regulation specifications for changes in output voltage due to heating effects. Line and load regulation are measured at a constant junction temperature by low duty cycle pulse testing. Load regulation is measured at the output lead = 1/18" from the package.

Note2: Line and load regulation are guaranteed up to the maximum power dissipation of 15W. Power dissipation is determined by the difference between input and output differential and the output current. Guaranteed maximum power dissipation will not be available over the full input/output range.

Note3: Quiescent current is defined as the minimum output current required in maintaining regulation. At 12V input/output differential the device is guaranteed to regulate if the output current is greater than 10mA.

Note4: Tap is connected to the multi-layer PCB copper area 10mm*10mm.

❖ APPLICATION CIRCUIT

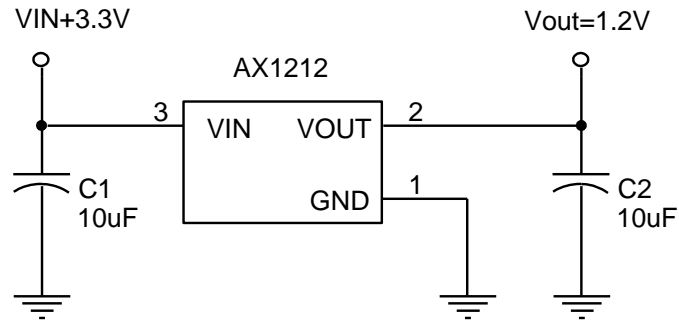

❖ TYPICAL CHARACTERISTICS

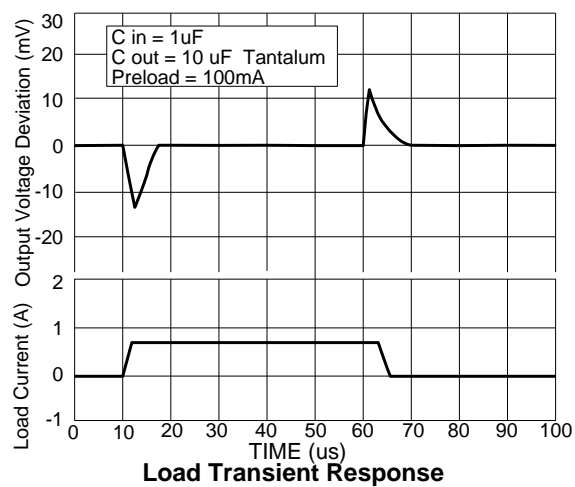
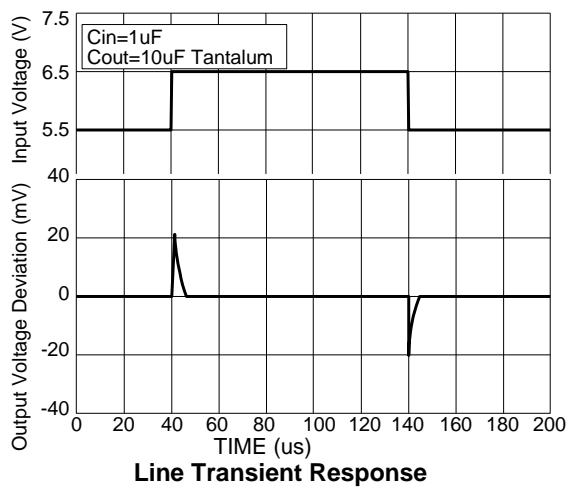
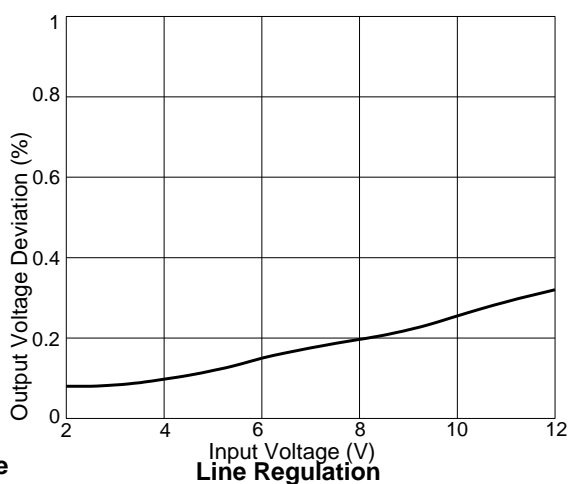
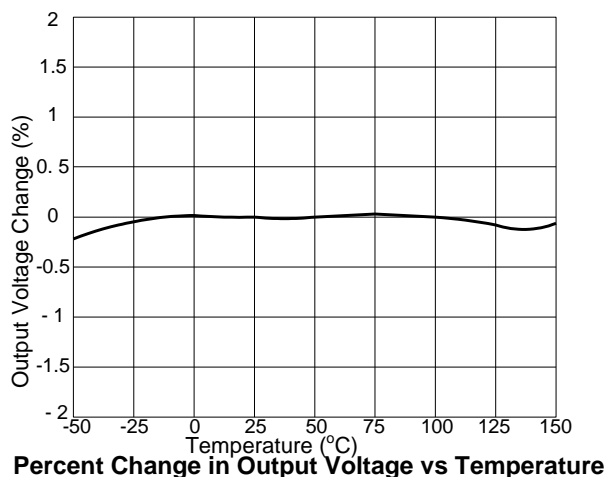
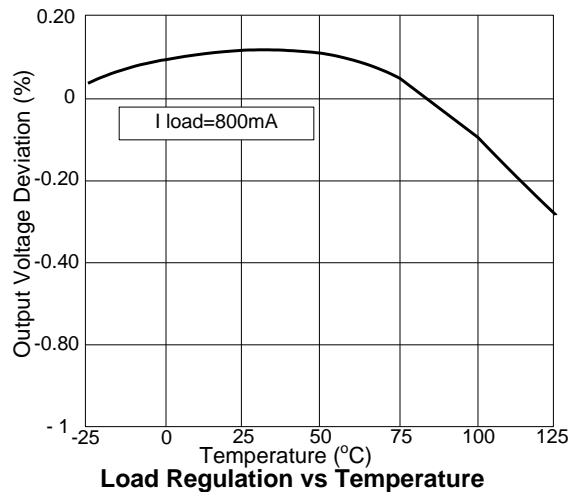
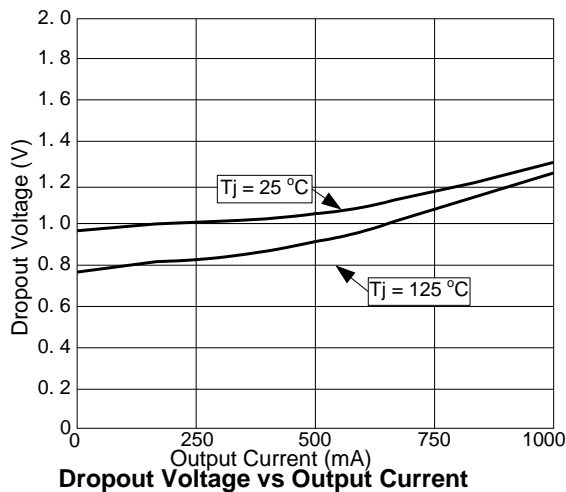

❖ PACKAGE OUTLINES

(1) SOT223-3L

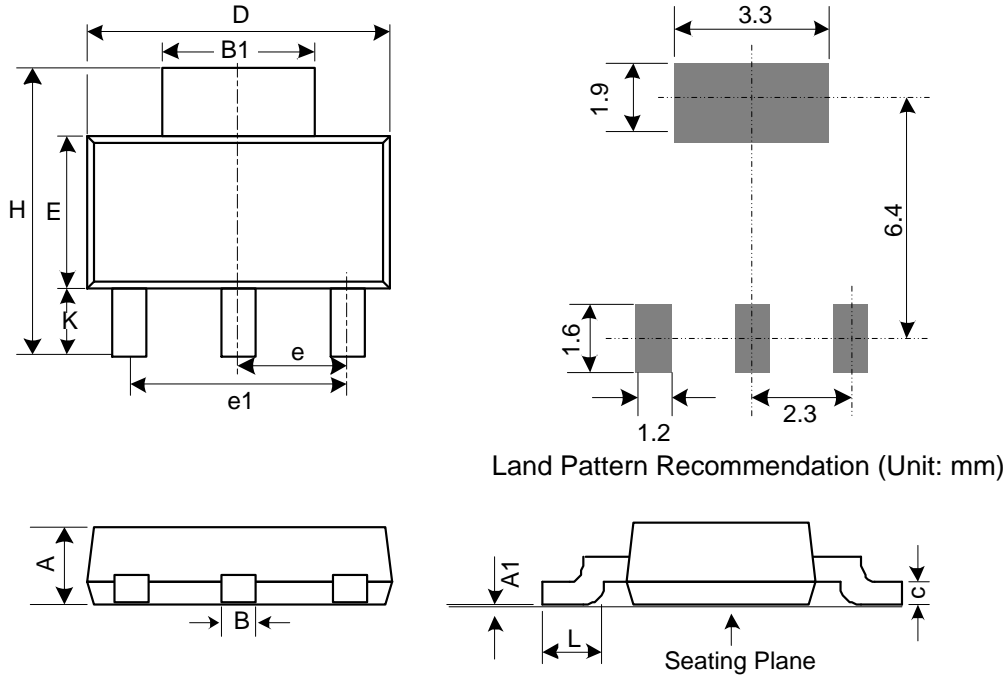

Symbol	Dimensions in Millimeters			Dimensions in Inches		
	Min.	Nom.	Max.	Min.	Nom.	Max.
A	-	-	1.8	-	-	0.071
A1	0.02	0.06	0.1	0.001	0.002	0.004
B	0.66	0.75	0.84	0.026	0.03	0.033
B1	2.9	3	3.1	0.114	0.118	0.122
C	0.23	0.315	0.35	0.009	0.012	0.014
D	6.3	6.5	6.7	0.248	0.256	0.264
E	3.3	3.5	3.7	0.13	0.138	0.146
H	6.7	7	7.3	0.264	0.278	0.287
L	0.75	-	-	0.03	-	-
K	1.5	1.75	2	0.059	0.069	0.079
e	2.3 Basic			0.091 Basic		
e1	4.6 Basic			0.181 Basic		

JEDEC outline: TO-261 AB

(2) T0252-3L

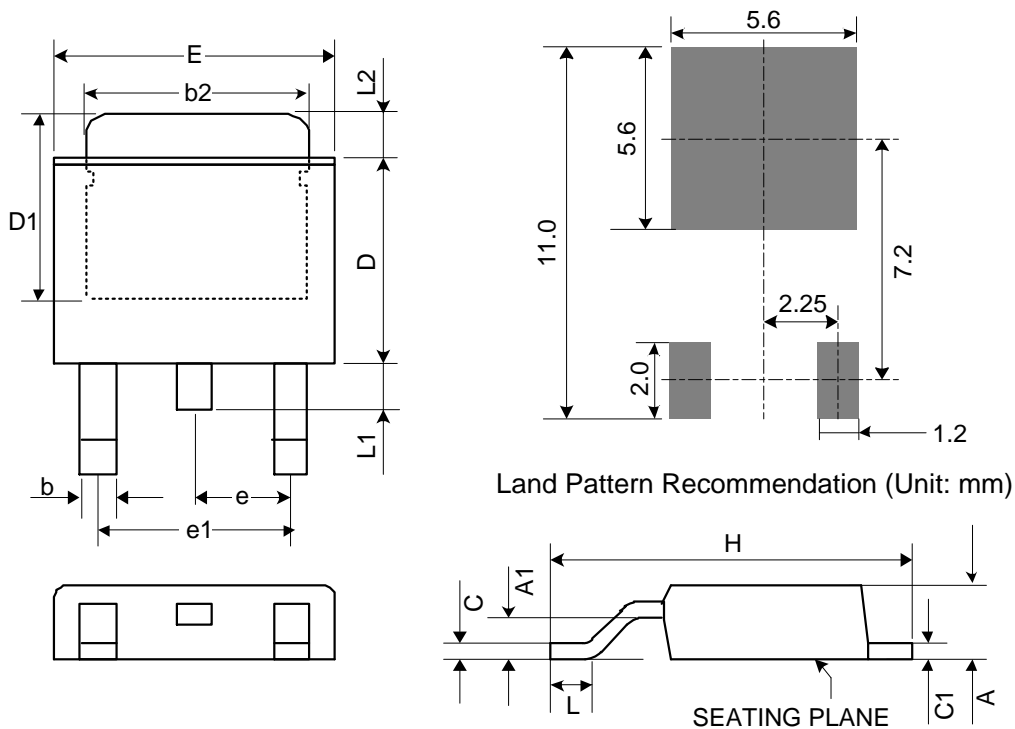

Symbol	Dimensions in Millimeters			Dimensions in Inches		
	Min.	Nom.	Max.	Min.	Nom.	Max.
A	2.18	2.29	2.39	0.086	0.09	0.094
A1	-	-	0.13	-	-	0.005
b	0.51	0.71	0.89	0.02	0.028	0.035
b2	4.95	5.21	5.46	0.195	0.205	0.215
C	0.46	0.53	0.61	0.018	0.021	0.024
C1	0.46	0.53	0.58	0.018	0.021	0.023
D	5.33	5.46	6.22	0.21	0.215	0.245
D1	4.57	-	-	0.18	-	-
E	6.35	6.55	6.73	0.25	0.258	0.265
e	2.29 BSC			0.090 BSC.		
e1	4.58 BSC			0.180 BSC.		
H	9.4	9.7	10.4	0.37	0.382	0.41
L	1.4	1.6	1.78	0.055	0.063	0.07
L1	-	-	1.02	-	-	0.04
L2	1.52	1.78	2.03	0.06	0.07	0.08

Mold flash shall not exceed 0.005inch per side
JEDEC outline: TO-252