

## **38KHz, 1A PWM Buck DC/DC Converter**

### ❖ GENERAL DESCRIPTION

The AX3024A series are monolithic IC designed for a step-down DC/DC converter, and own the ability of driving a 1A load without additional transistor. It saves board space. The external shutdown function can be controlled by logic level and then come into standby mode. The internal compensation makes feedback control having good line and load regulation without external design. Regarding protected function, thermal shutdown is to prevent over temperature operating from damage, and current limit is against over current operating of the output switch. The AX3024A operates at a switching frequency of 38KHz. Other features include a guaranteed +3% tolerance on output voltage under specified input voltage and output load conditions, The chips are available in SOT-23-5L and SOP-8L packages.

### ❖ FEATURES

- Output voltage: adjustable output version.
- Adjustable version output voltage range: 0.745V to 22V±3%.
- Fixed switching frequency is 38KHz
- Thermal-shutdown and current-limit protection.
- ON/OFF shutdown control input (SOT-23-5L Only).
- Operating voltage can be up to 24V.
- Output load current: 1A.
- SOT-23-5L and SOP-8L packages.
- Low power standby mode.
- Built-in switching transistor on chip.

❖ **BLOCK DIAGRAM**

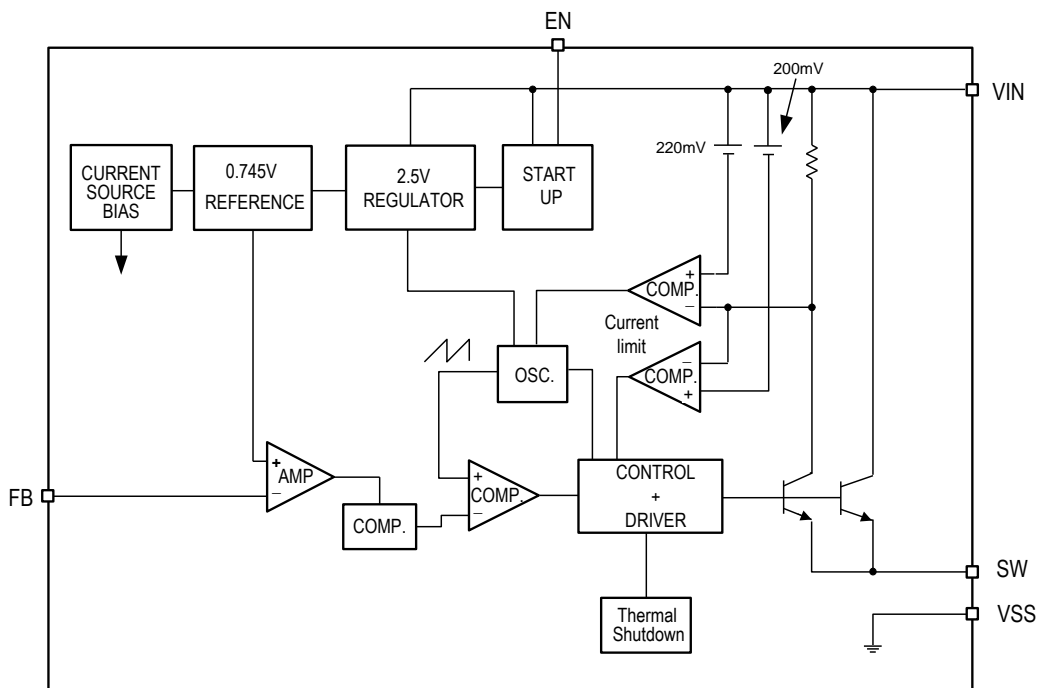

❖ **PIN ASSIGNMENT**

The packages of AX3024A are SOT-23-5L and SOP-8L; the pin assignment is given by:

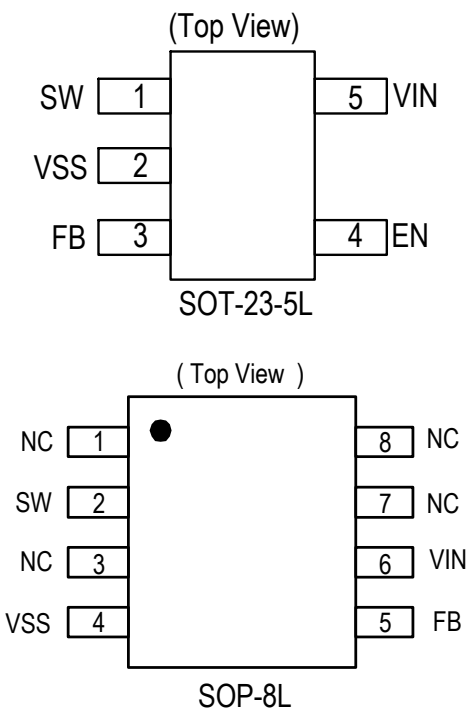

Name	Description
VIN	Operating voltage input
SW	Switching output
FB	Output voltage feedback control
EN	ON/OFF Shutdown (SOT-23-5L Only)
VSS	Ground pin
NC	No connect Pin

❖ **ORDER/MARKING INFORMATION**

Order Information	
<b>AX3024A X X</b> Package Type    Packing B: SOT-23-5L    Blank : Tube S: SOP-8L        A : Taping	
Top Marking (SOP-8L)	Top Marking (SOT-23-5L)
Logo ← <b>AX</b> 3 0 2 4 → Part number A Y Y W W X → ID code: internal WW: 01~52 Year: 10=2010 11=2011 AX3024A	N4Y W X → ID code:internal WW:01~26 (A~Z) 27~52 (a~z) Year: A=2010 1=2011 AX3024A

❖ **ABSOLUTE MAXIMUM RATINGS**

Characteristics	Symbol	Rating	Unit
Maximum Supply Voltage	$V_{IN}$	+26	V
ON/OFF Pin Input Voltage	$V_{EN}$	-0.3 to $V_{IN}$	V
Feedback Pin Voltage	$V_{FB}$	-0.3 to 5	V
Output Voltage to Ground	$V_{OUT}$	-0.8 to $V_{IN}$	V
Power Dissipation Internally limited	PD	$(T_J - T_A) / \theta_{JA}$	W
Storage Temperature Range	$T_{ST}$	-65 to +165	°C
Junction Temperature Range	$T_J$	-40 to +150	°C
Operating Supply Voltage	$V_{OP}$	+4.5 to +24	V
Thermal Resistance from Junction to case	SOP-8L	50	°C/W
	SOT-23-5L	180	
	SOT-23-5L (Note)	110	
Thermal Resistance from Junction to ambient	SOP-8L	120	°C/W
	SOT-23-5L	250	
	SOT-23-5L (Note)	220	

Note:  $\theta_{JA}$  is measured with the PCB copper area (need connect to  $V_{SS}$  pins) of approximately 1.5 in<sup>2</sup> (Multi-layer).

❖ ELECTRICAL CHARACTERISTICS

(Unless otherwise specified,  $T_A=25^{\circ}\text{C}$ ,  $V_{IN}=12\text{V}$ ;  $V_{OUT}=3.3\text{V}$ ,  $I_{LOAD}=0.3\text{A}$ )

Characteristics	Symbol	Conditions	Min	Typ	Max	Units
Feedback Voltage	$V_{FB}$	$I_{OUT}=0.3\text{A}$	0.723	0.745	0.767	V
Quiescent Current	$I_Q$	$V_{FB}=1.2\text{V}$ force driver off	-	3.5	6	mA
Feedback bias current	$I_{FB}$	$I_{OUT}=0.1\text{A}$	-	-10	-50	nA
Oscillator frequency	$F_{OSC}$		30	38	46	KHz
Max. Duty Cycle (ON)	DC	$V_{FB}=1.2\text{V}$ force driver off	-	0	-	%
Min. Duty Cycle (OFF)		$V_{FB}=0\text{V}$ force driver on	-	100	-	
Current limit	$I_{CL}$	Peak current, No outside circuit $V_{FB}=0\text{V}$ force driver on	1.3	-	-	A
Saturation voltage	$V_{SAT}$	$I_{OUT}=1\text{A}$ , No outside circuit $V_{FB}=0\text{V}$ force driver on	-	1.2	1.5	V
SW pin=0V	SW pin leakage current	$V_{IN}=24\text{V}$ , No outside circuit $V_{FB}=1.0\text{V}$ force driver off	-	-	-200	uA
SW pin=-0.8V			-	-5	-	
Thermal shutdown Temp	$T_{SD}$		-	145	-	$^{\circ}\text{C}$
<b>Enable Function (SOT-23-5L Only)</b>						
EN pin logic input threshold voltage	$V_{IH}$	High (regulator ON)	-	-	2.0	V
	$V_{IL}$	Low (regulator OFF)	0.5	-	-	
Shutdown supply Current	$I_{SD}$	$V_{EN}=0\text{V}$	-	2	10	uA
EN pin logic input current	$I_H$	$V_{EN}=2.5\text{V}$ (ON)	-	20	-	uA
EN pin input current	$I_L$	$V_{EN}=0.3\text{V}$ (OFF)	-	-5	-	

❖ APPLICATION CIRCUIT

Adjustable Output Voltage Version

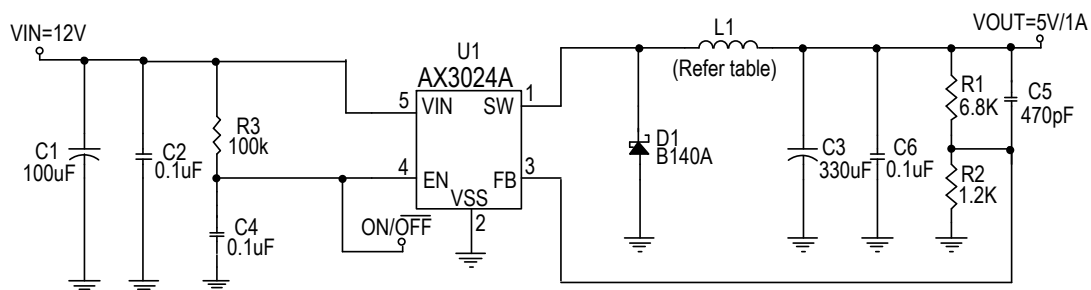

$$V_{OUT} = V_{FB} \times \left(1 + \frac{R1}{R2}\right), V_{FB} = 0.745V, R2 = 0.75K \sim 4K$$

Table 1 Resistor select for output voltage setting

V <sub>OUT</sub>	R2	R1
5V	1.2K	6.8K
3.3V	2.4K	8.2K
2.5V	2K	4.7K
1.8V	3.3K	4.7K
1.5V	2K	2K
1.3V	2K	1.5K
1.2V	2K	1.2K

L1 recommend value (V <sub>IN</sub> =12V ,I <sub>OUT</sub> =1A)				
V <sub>OUT</sub>	1.8 V	2.5V	3.3V	5V
L1 Value	100uH	120uH	150uH	180uH

## ❖ FUNCTION DESCRIPTIONS

### Pin Functions

#### VIN

This is the positive input supply for the IC switching regulator. A suitable input bypass capacitor must be presented at this pin to minimize voltage transients and to supply the switching currents needed by the regulator.

#### VSS

Circuit ground.

#### SW

Internal switch. The voltage at this pin switches between (+V<sub>IN</sub> - V<sub>SAT</sub>) and approximately - 0.5V, with a duty cycle of approximately V<sub>OUT</sub> / V<sub>IN</sub>. To minimize coupling to sensitive circuitry, the PC board copper area connected to this pin should be minimized.

**FB**

Sense the regulated output voltage to complete the feedback loop.

**EN (SOT-23-5L Only)**

Allow the switching regulator circuit to be shutdown using logic level signals thus dropping the total input supply current to approximately 2uA. Pulling this pin below a threshold voltage of approximately 0.5V shuts the regulator down, and pulling this pin above 2.0V (up to a maximum of  $V_{IN}$ ) turns the regulator on.

❖ TYPICAL CHARACTERISTICS

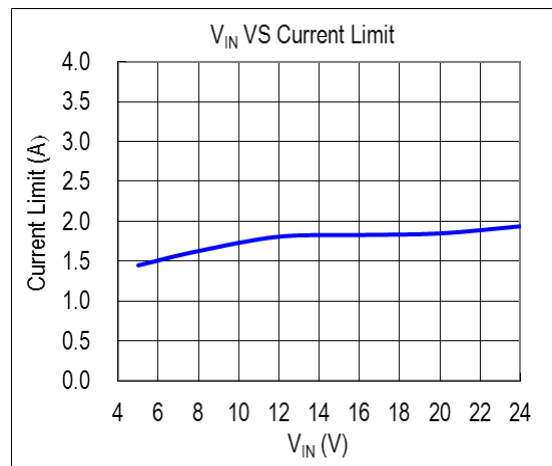
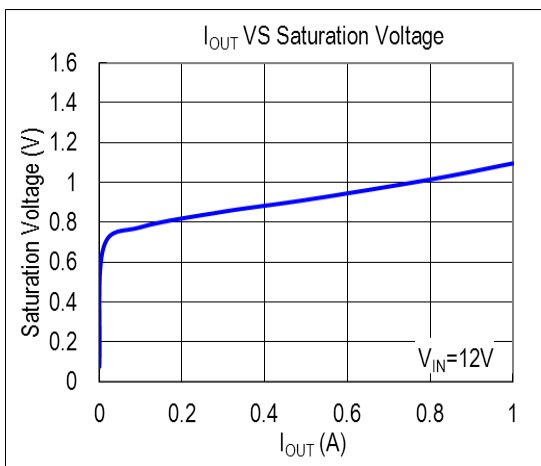
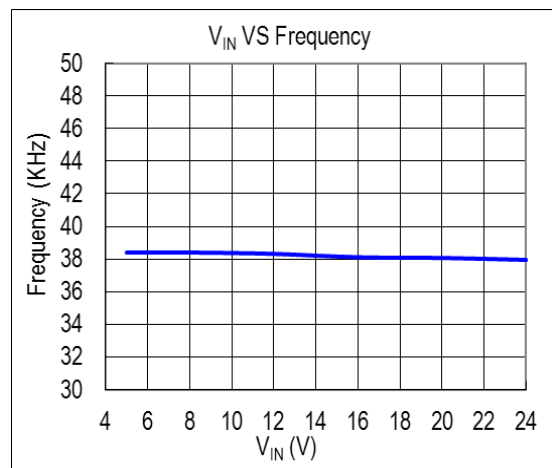
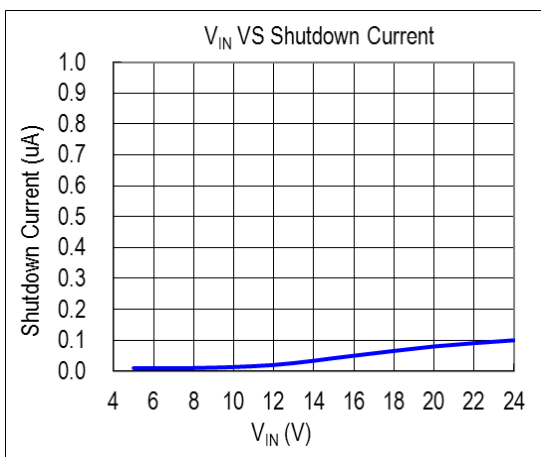
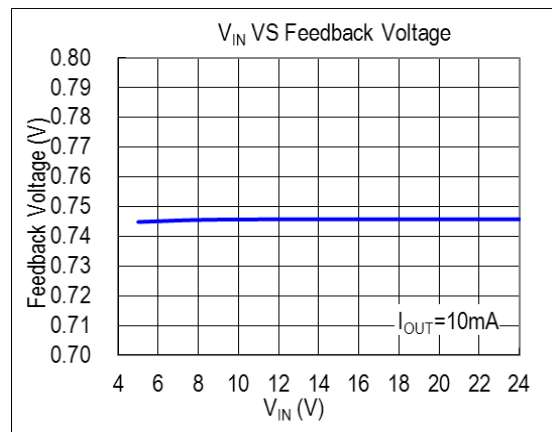
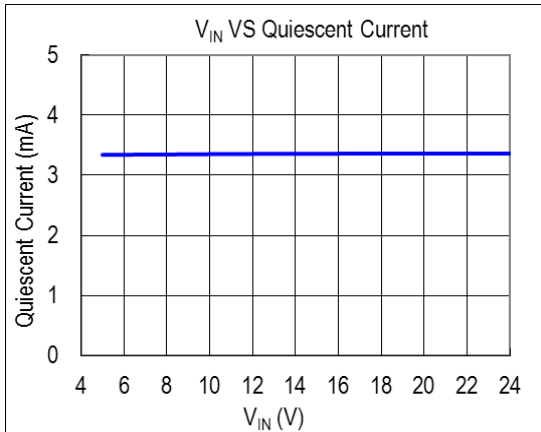

❖ TYPICAL CHARACTERISTICS (CONTIUNES)

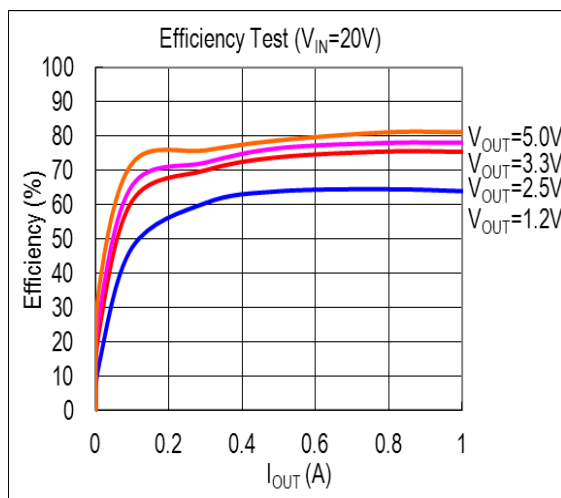
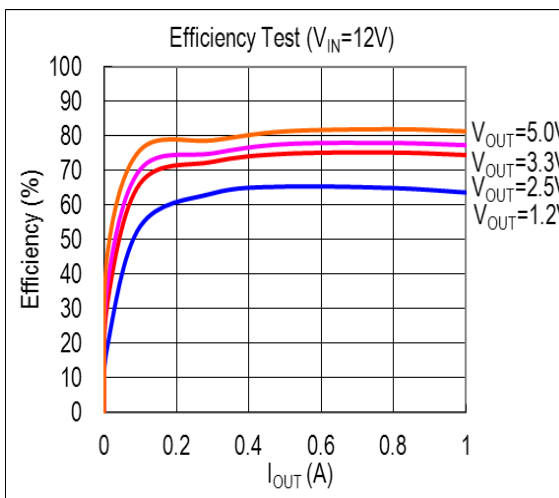
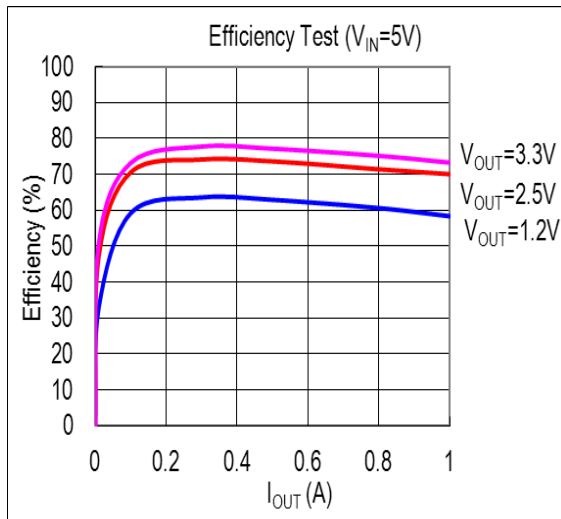
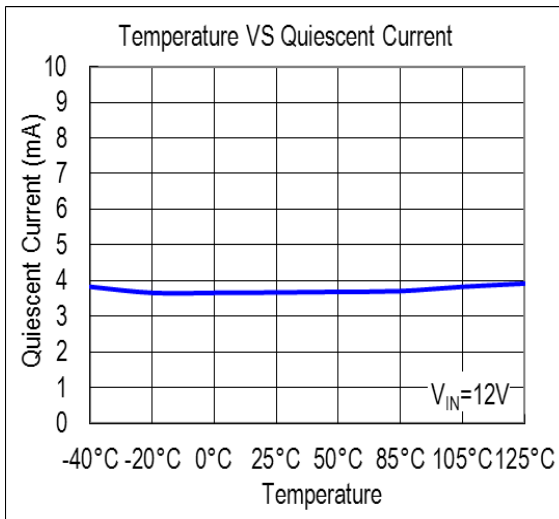
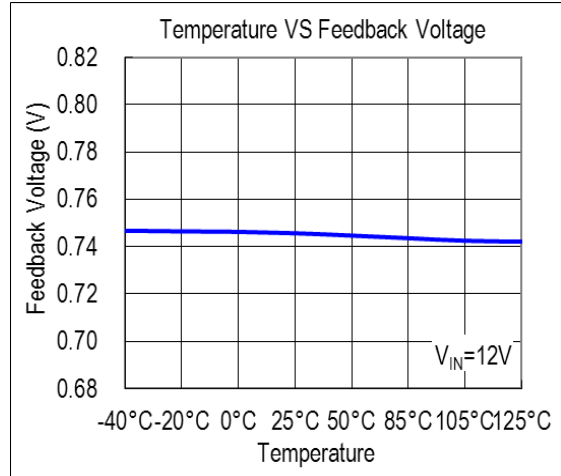
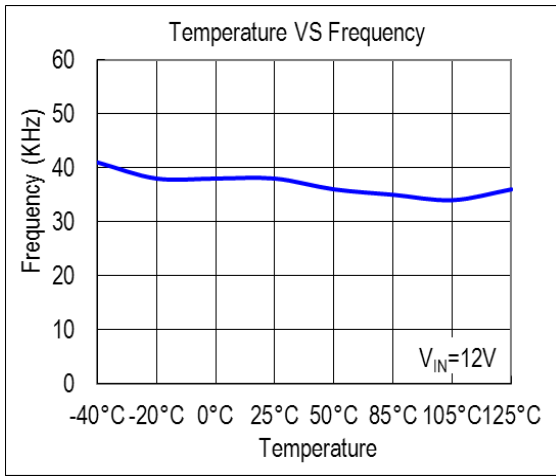



❖ TYPICAL CHARACTERISTICS (CONTIUNES)

Power – ON

( $V_{IN}=12V$ ,  $V_{OUT}=2.5V$ ,  $I_{OUT}=1A$ )

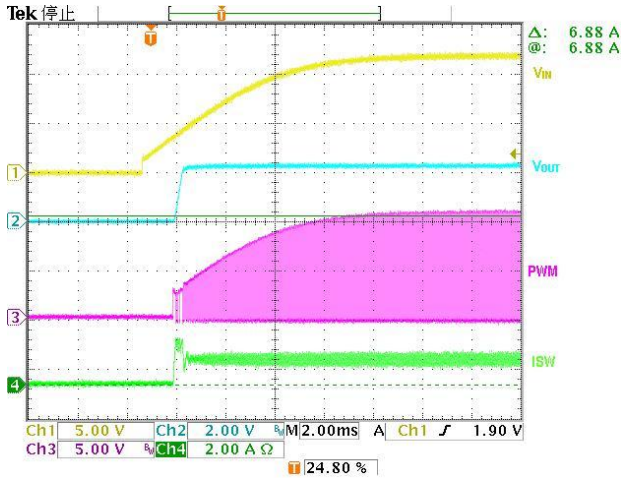

Enable – ON

( $V_{IN}=12V$ ,  $V_{OUT}=2.5V$ ,  $I_{OUT}=1A$ )

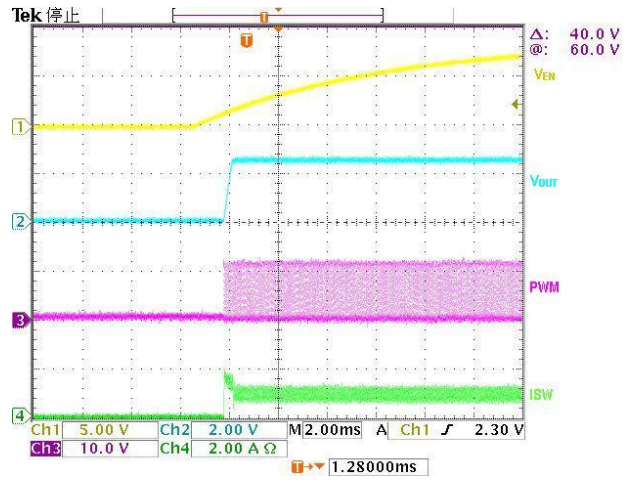

Load Transient

( $V_{IN}=12V$ ,  $V_{OUT}=2.5V$ ,  $I_{OUT}=0.1\sim 1A$ )

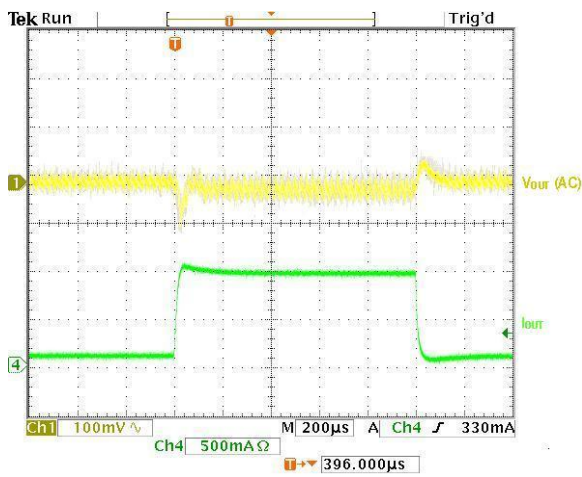

Load Transient

( $V_{IN}=12V$ ,  $V_{OUT}=3.3V$ ,  $I_{OUT}=0.1\sim 1A$ )

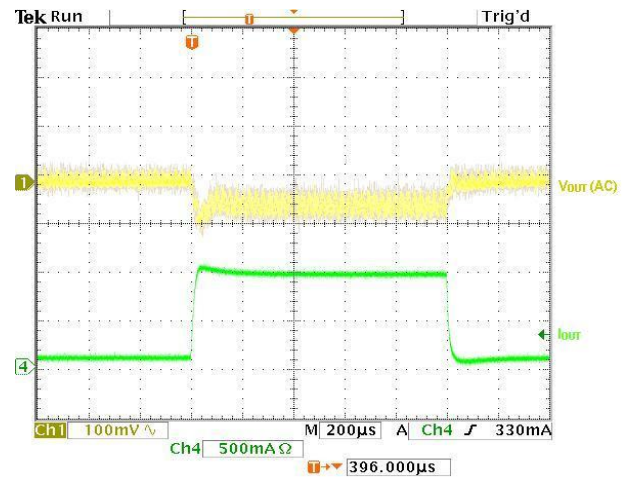

❖ PACKAGE OUTLINES

(1) SOP-8L

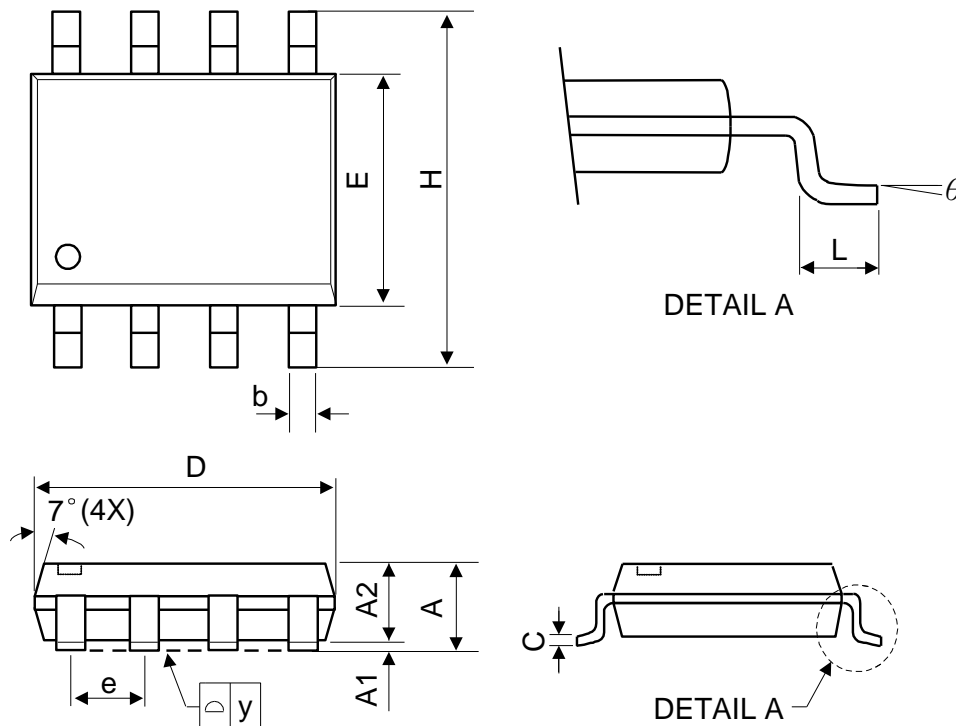

Symbol	Dimensions in Millimeters			Dimensions in Inches		
	Min.	Nom.	Max.	Min.	Nom.	Max.
A	-	-	1.75	-	-	0.069
A1	0.1	-	0.25	0.04	-	0.1
A2	1.25	-	-	0.049	-	-
C	0.1	0.2	0.25	0.0075	0.008	0.01
D	4.7	4.9	5.1	0.185	0.193	0.2
E	3.7	3.9	4.1	0.146	0.154	0.161
H	5.8	6	6.2	0.228	0.236	0.244
L	0.4	-	1.27	0.015	-	0.05
b	0.31	0.41	0.51	0.012	0.016	0.02
e	1.27 BSC			0.050 BSC		
y	-	-	0.1	-	-	0.004
θ	0°	-	8°	0°	-	8°

Mold flash shall not exceed 0.25mm per side

JEDEC outline: MS-012 AA

(2) SOT-23-5L

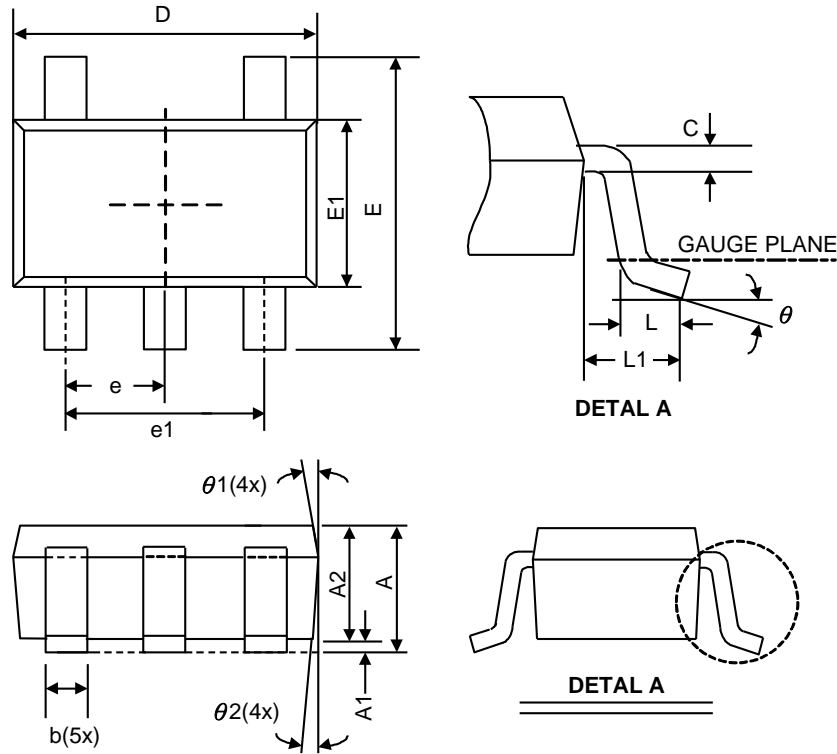

Symbol	Dimensions in Millimeters			Dimensions in Inches		
	Min.	Nom.	Max.	Min.	Nom.	Max.
A	-	-	1.45	-	-	0.057
A1	0.00	0.08	0.15	0	0.003	0.006
A2	0.90	1.10	1.30	0.035	0.043	0.051
b	0.30	0.40	0.50	0.012	0.016	0.020
C	0.08	0.15	0.22	0.003	0.006	0.009
D	2.70	2.90	3.10	0.106	0.114	0.122
E1	1.40	1.60	1.80	0.055	0.063	0.071
E	2.60	2.80	3.00	0.102	0.110	0.118
L	0.30	0.45	0.60	0.012	0.018	0.024
L1	0.50	0.60	0.70	0.020	0.024	0.028
e1	1.9 BSC			0.075 BSC		
e	0.95 BSC			0.037 BSC		
$\theta$	0°	4°	8°	0°	4°	8°
$\theta 1$	5°	10°	15°	5°	10°	15°
$\theta 2$	5°	10°	15°	5°	10°	15°

JEDEC outline: MO-178 AA