

## 100mA Ultra-Low Quiescent Current Low Dropout Regulator

### ❖ GENERAL DESCRIPTION

The AX6648 is a CMOS low dropout voltage (LDO) regulator with ultra-low quiescent current of  $4\mu\text{A}$ , designed for battery-operated applications. Wide range of output voltages can be used, ranging from 1.2V to 3.3V.

Other features include current limit protection, thermal shutdown protection and high output voltage accuracy. The requirement of only  $1\mu\text{F}$  for input and output capacitors makes it ideal in space-sensitive applications.

The AX6648 is available in space saving 3-pin TSOT-23-3L, 5-pin TSOT-23-5L and 6-pin TDFN-6L packages.

### ❖ FEATURES

- Ultra-Low Quiescent current at  $4\mu\text{A}$
- High Output Voltage Accuracy at  $\pm 2\%$
- Low Dropout Voltage of 450mV at 100mA
- Wide Input Operating Voltage Range from 2 to 5.5V
- Current Limit Protection
- Thermal Shutdown Protection
- $1\mu\text{F}$  Output Capacitor Required for Stability
- Chip Enable Control (AX6648XXBT and AX6648XXZ6 Only)
- RoHS Compliant
- Available in the TSOT-23-3L , TSOT-23-5L and TDFN-6L Packages

### ❖ BLOCK DIAGRAM

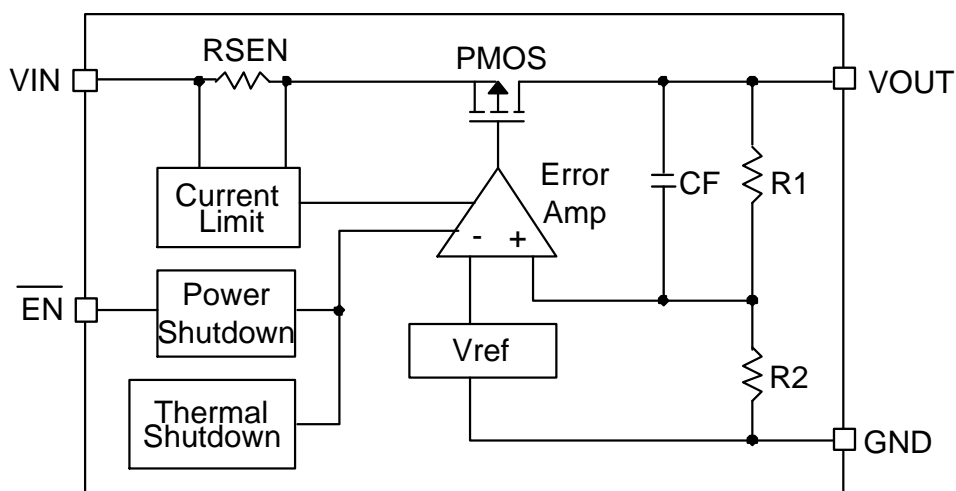

❖ **PIN ASSIGNMENT**

The packages of AX6648 are TSOT-23-3L, TSOT-23-5L and TDFN-6L; the pin assignment is given by:

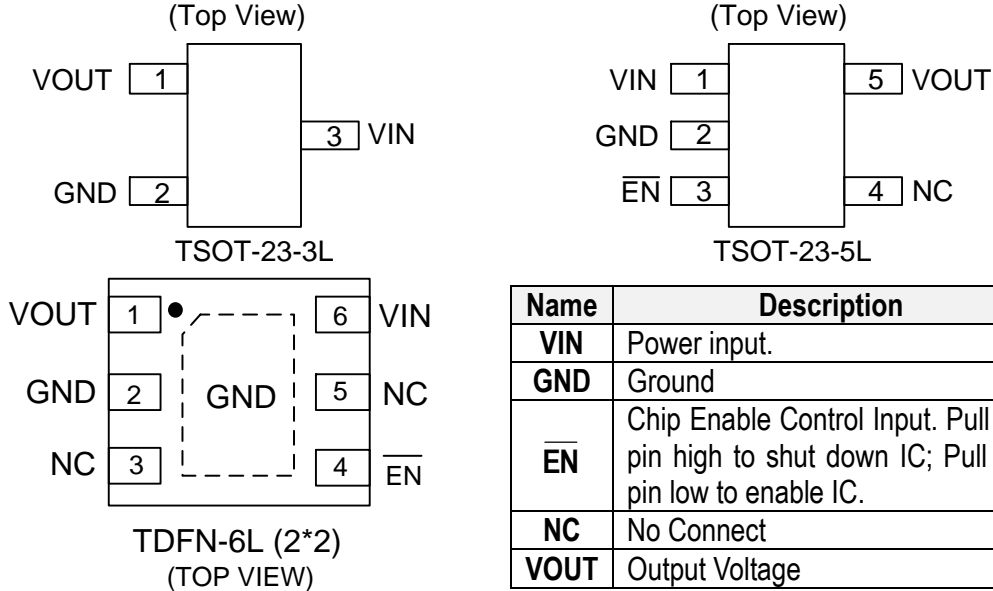

❖ **ORDER/MARKING INFORMATION**

Order Information	
<b>AX6648 - XX XX X</b>	
Output voltage	Package      Packing
12 : 1.2V	RT : TSOT-23-3L    Blank: Bag
15 : 1.5V	BT : TSOT-23-5L    A : Taping
18 : 1.8V	Z6 : TDFN-6L
25 : 2.5V	
30 : 3.0V	
33 : 3.3V	
Top Marking (TSOT-23-3L/TSOT-23-5L)	Top Marking (TDFN-6L)

**Appendix**

Part Number	Identification Code
	TSOT-23-3L /TDFN-6L
AX6648-1.2V	AA
AX6648-1.5V	AB
AX6648-1.8V	AC
AX6648-2.5V	AD
AX6648-3.0V	AE
AX6648-3.3V	AF

**❖ ABSOLUTE MAXIMUM RATINGS (at T<sub>A</sub>=25°C)**

Characteristics	Symbol	Rating	Unit
Input Voltage	V <sub>IN</sub>	+2.0 to +5.5	V
$\overline{\text{EN}}$ Pin Voltage	V <sub>EN</sub>	V <sub>IN</sub> + 0.3	V
Power Dissipation	PD	(T <sub>J</sub> -T <sub>A</sub> ) / θ <sub>JA</sub>	mW
Storage Temperature Range	T <sub>ST</sub>	-65 to +150	°C
Lead Temperature (Soldering, 10sec.)		260	°C
Junction Temperature	T <sub>J</sub>	+150	°C
Operating Temperature Range		-40 to +85	°C
Thermal Resistance from Junction to case	TSOT-23-3L	180	°C/W
	TDFN-6L	25	
Thermal Resistance from Junction to ambient	TSOT-23-3L	250	°C/W
	TDFN-6L	120	

Note: θ<sub>JA</sub> is measured with the PCB copper area of approximately 1 in<sup>2</sup> (Multi-layer). That need connect to GND pin.

**❖ ELECTRICAL CHARACTERISTICS**

(V<sub>IN</sub>=5.5V, V<sub>EN</sub>=0V, C<sub>IN</sub>= 1uF, T<sub>A</sub>=25°C, unless otherwise noted)

Characteristics	Symbol	Conditions	Min	Typ	Max	Units
Input Voltage Range	V <sub>IN</sub>		2	-	5.5	V
Output Voltage Accuracy	ΔV <sub>OUT</sub>	I <sub>OUT</sub> =1mA	-2	-	+2	%
Maximum Output Current	I <sub>MAX</sub>	V <sub>IN</sub> =V <sub>OUT</sub> +0.6V, V <sub>IN</sub> ≥ 3.6V	100	-	-	mA
Current Limit	I <sub>LIMIT</sub>	R <sub>LOAD</sub> =1Ω	150	-	-	mA
Quiescent Current	I <sub>Q</sub>	No load	-	4	7	μA
Dropout Voltage	V <sub>DROP</sub>	I <sub>OUT</sub> =50mA	-	200	300	mV
		I <sub>OUT</sub> =100mA	-	450	600	mV
Line Regulation	ΔV <sub>LINE</sub>	V <sub>IN</sub> =(V <sub>OUT</sub> +0.3V) to 6V, V <sub>IN</sub> ≥ 3.6V, I <sub>OUT</sub> =1mA	-0.2	-	+0.2	%/V
Load Regulation	ΔV <sub>LOAD</sub>	I <sub>OUT</sub> =0 to 100mA	-	0.01	-	%/mA
Ripple Rejection	P <sub>SRR</sub>	Freq.=1kHz, C <sub>OUT</sub> =1μF	-	30	-	dB
Standby Current	I <sub>SD</sub>	V <sub>EN</sub> =V <sub>IN</sub>	-	0.1	-	μA
$\overline{\text{EN}}$ Threshold Voltage	V <sub><math>\overline{\text{EN}}</math></sub>		0.6	1	2	V
Temperature Shutdown	T <sub>S</sub>		-	150	-	°C
Temperature Shutdown Hysteresis	T <sub>SH</sub>		-	20	-	°C

## ❖ APPLICATION CIRCUIT

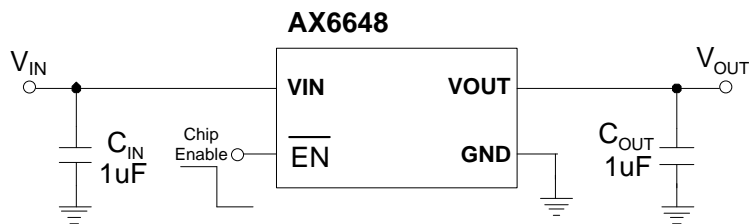

## ❖ APPLICATION INFORMATION

The AX6648 is suitable for power saving battery application with ultra-low 4µA quiescent current. Current limit and on chip thermal shutdown features provide protection against any combination of overload or ambient temperature that could exceed maximum junction temperature.

### Shutdown Control

Force  $\overline{\text{EN}}$  pin low to enable the AX6648 and turn off the device by pulling it high. The  $\overline{\text{EN}}$  pin can't be floated and must be tied to the ground if not used.

### Thermal Shutdown

Thermal shutdown is employed to protect the device damage from the junction temperature exceed safe margins due mainly to short circuit or current limit. Moreover, the device returns normally operation when the junction temperature protection circuit is built in to protect IC, the maximum power dissipation design within  $T_j(\text{max})$  is needed. The thermal protection is independent to each channel.

### Thermal Considerations

The power handling capability of the device will be limited by maximum 125°C operation junction temperature. The power dissipated by the device will be estimated by  $P_D = I_{\text{OUT}} \times (V_{\text{IN}} - V_{\text{OUT}})$ . The power dissipation should be lower than the maximum power dissipation listed in "Absolute Maximum Ratings" section.

## Capacitor Selection

The ceramic capacitor is ideal for AX6648 application. The ESR of the output capacitor affects stability. Larger value of the output capacitor decreases the peak deviations and improves transient response for larger current changes.

The capacitor types (ceramic, aluminum, and tantalum) have different characterizations such as voltage and temperature coefficients. All ceramic capacitors are manufactured with a variety of dielectrics, each with different behavior across temperature and applications. Common dielectrics used are X5R, X7R and Y5V. It is recommended to use 1 $\mu$ F to 10 $\mu$ F X5R or X7R dielectric ceramic capacitors because X5E or X7R hold their capacitance over wide voltage and temperature ranges than other Y5V or Z5U types. The ESR of output capacitor is very important because it generates a zero to provide phase lead for loop stability. The input capacitor can reduced peak current and noise at power source.

❖ TYPICAL CHARACTERISTICS

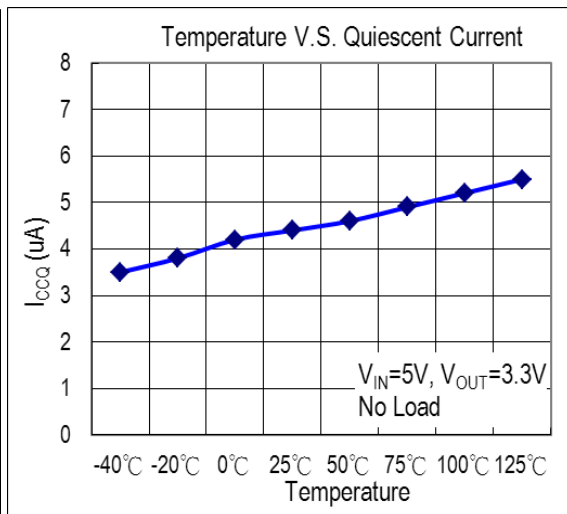
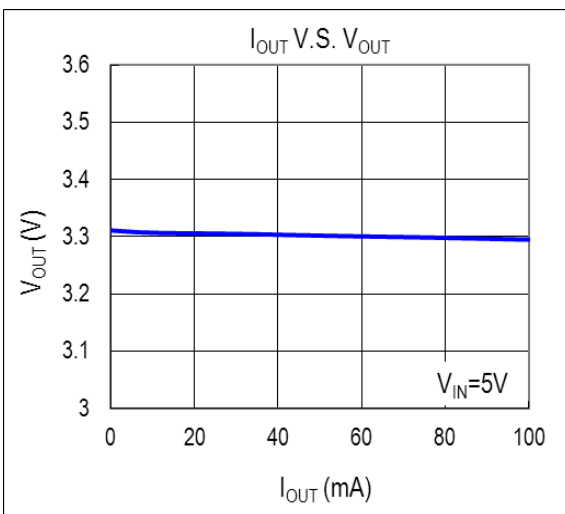
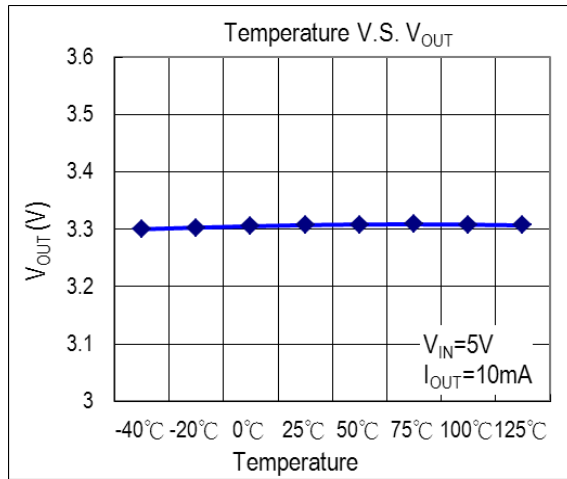
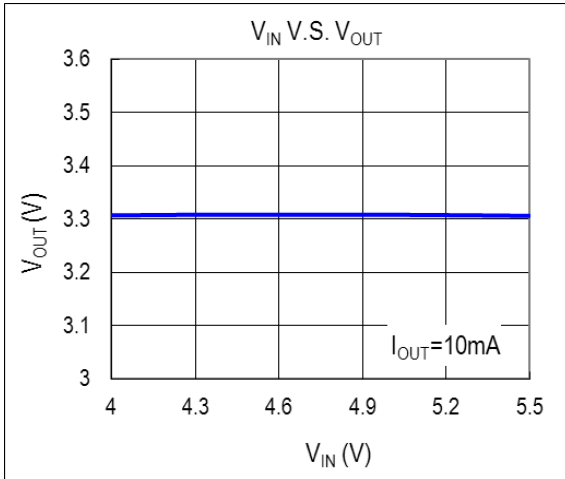
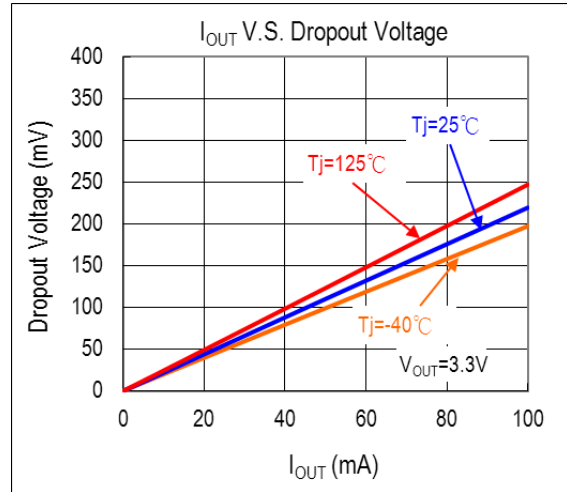
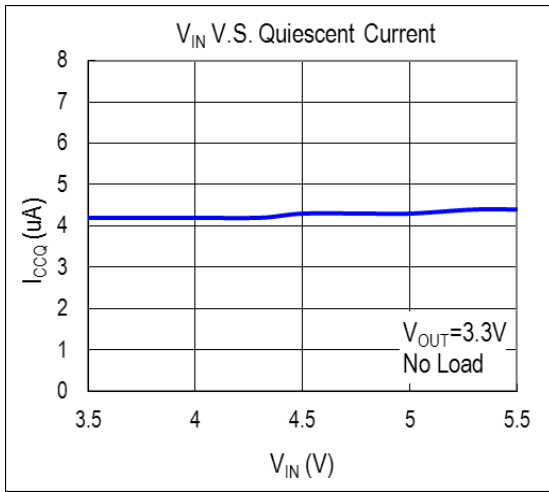

❖ TYPICAL CHARACTERISTICS (CONTINUES)

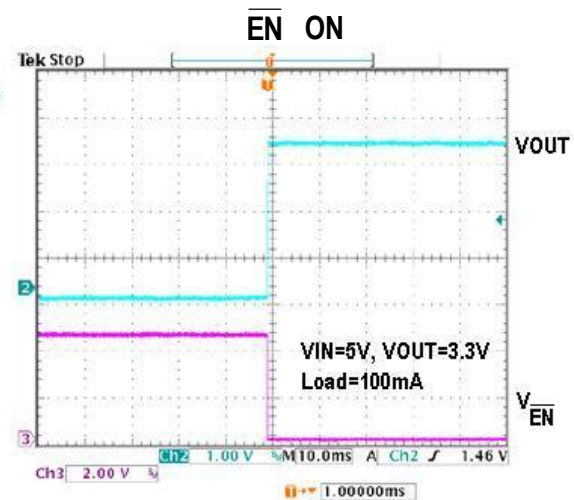
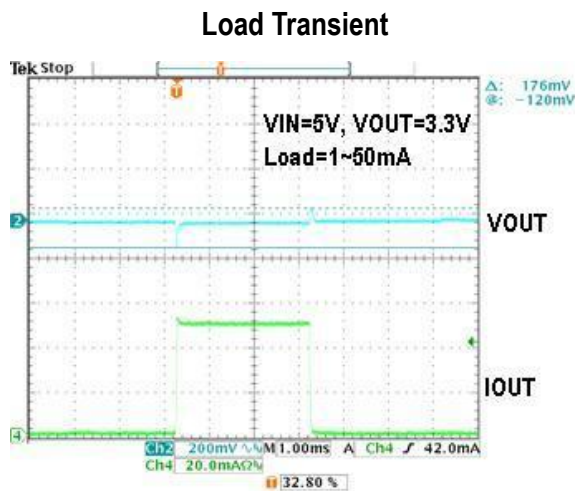
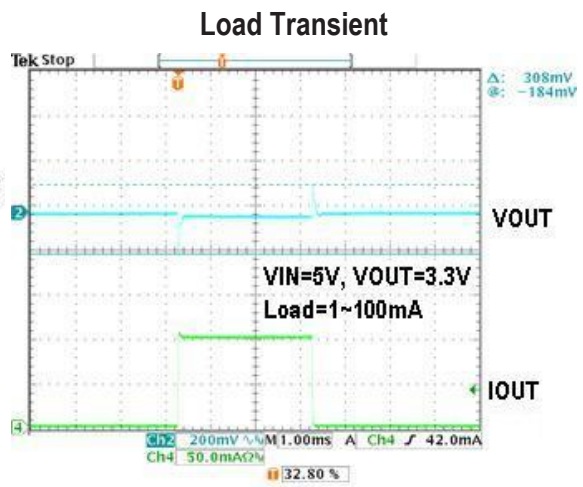
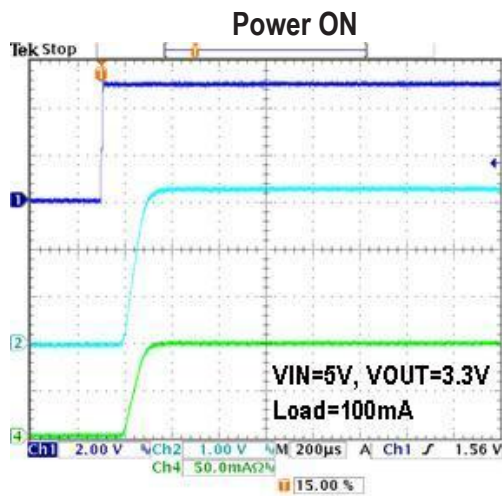

❖ PACKAGE OUTLINES

(1) TSOT-23-3L

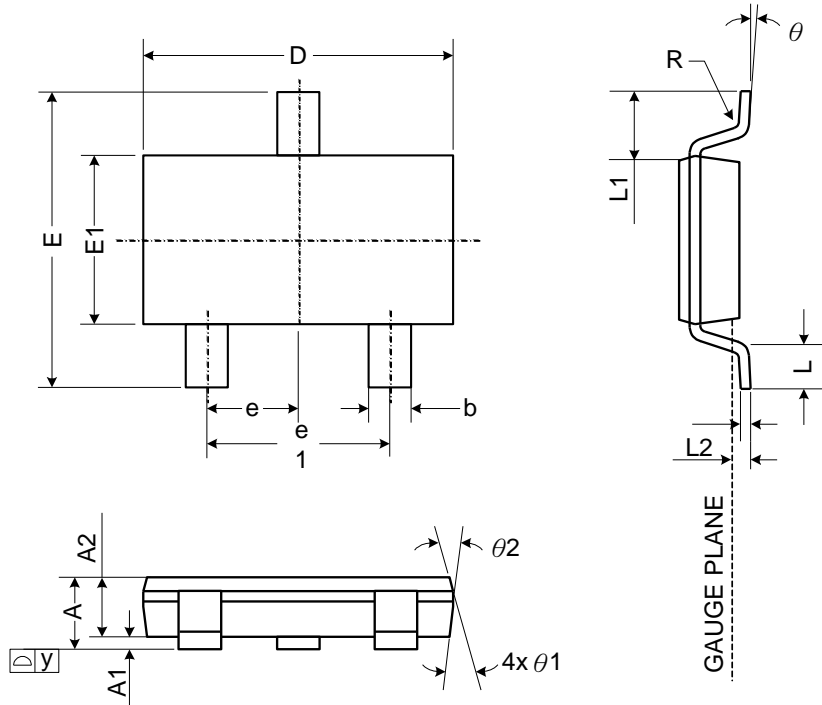

Symbol	Dimensions in Millimeters			Dimensions in Inches		
	Min.	Nom.	Max.	Min.	Nom.	Max.
A	0.75	-	0.90	0.030	-	0.035
A1	0.00	-	0.10	0.000	-	0.004
A2	0.70	0.75	0.80	0.028	0.030	0.031
b	0.35	-	0.51	0.014	-	0.020
C	0.10	-	0.25	0.004	-	0.010
D	2.80	2.90	3.00	0.110	0.114	0.118
E	2.60	2.80	3.00	0.102	0.110	0.118
E1	1.50	1.60	1.70	0.059	0.063	0.067
e	0.95 BSC.			0.037 BSC.		
e1	1.90 BSC.			0.075 BSC.		
L	0.37	-	-	0.015	-	-
L1	0.60 REF.			0.024 REF.		
L2	0.25 BSC.			0.010 BSC.		
y	-	-	0.10	-	-	0.004
R	0.10	-	-	0.004	-	-
theta	0°	-	8°	0°	-	8°
theta1	7° NOM.			7° NOM.		
theta2	5° NOM.			5° NOM.		



(2) TSOT-23-5L

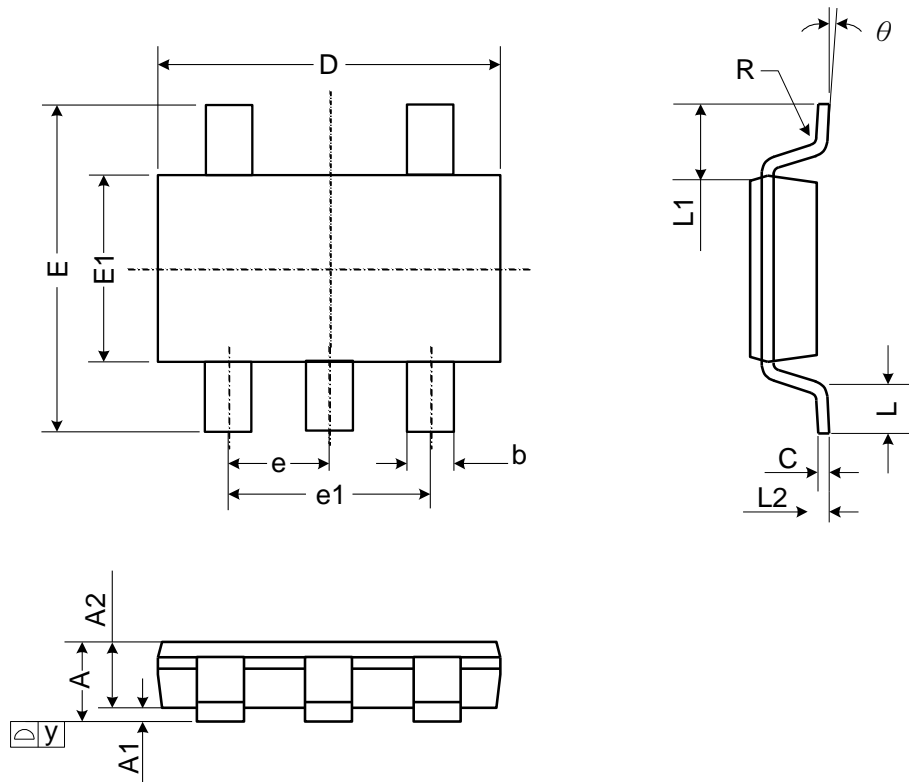

Symbol	Dimensions in Millimeters			Dimensions in Inches		
	Min.	Nom.	Max.	Min.	Nom.	Max.
A	-	-	1.10	-	-	0.043
A1	0.00	-	0.10	0	-	0.004
A2	0.70	0.90	1.00	0.028	0.035	0.039
b	0.30	0.40	0.50	0.012	0.016	0.020
C	0.08	0.14	0.20	0.003	0.006	0.008
D	2.80	2.90	3.00	0.110	0.114	0.118
E	2.60	2.80	3.00	0.102	0.110	0.118
E1	1.50	1.60	1.70	0.059	0.063	0.067
e	0.95 BSC.			0.037 BSC.		
e1	1.90 BSC.			0.075 BSC.		
L	0.30	0.45	0.60	0.012	0.018	0.024
L1	0.60 REF.			0.024 REF.		
L2	0.25 BSC.			0.010 BSC.		
y	-	-	0.10	-	-	0.004
R	0.10	-	-	0.004	-	-
$\theta$	0°	-	8°	0°	-	8°

JECED outline: MO-193 AB

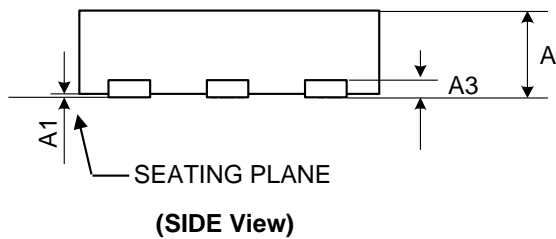
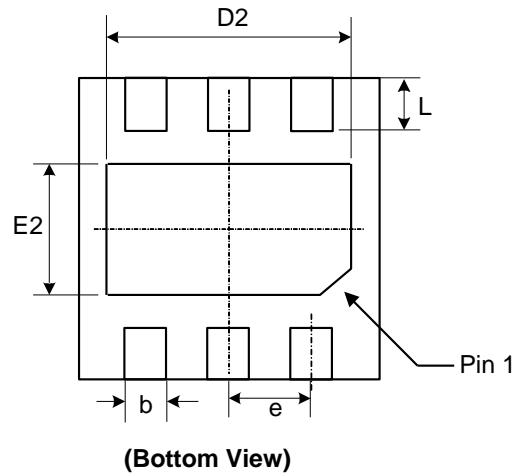
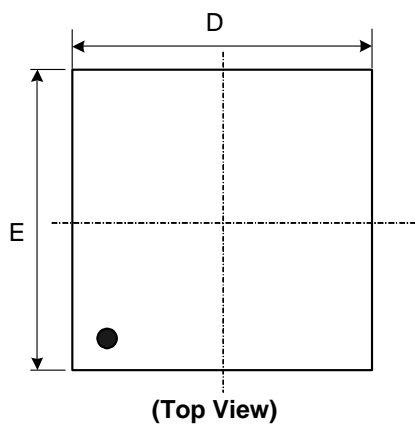
**(3) TDNF-6L**

Symbol	Dimensions in Millimeters			Dimensions in Inches		
	Min.	Nom.	Max.	Min.	Nom.	Max.
A	0.70	0.75	0.80	0.028	0.030	0.031
A1	0.00	0.02	0.05	0.000	0.001	0.002
A3	0.203 REF.			0.008 REF.		
b	0.20	0.28	0.35	0.009	0.011	0.013
D	1.95	2.00	2.05	0.077	0.079	0.081
D2	1.35	1.50	1.65	0.055	0.059	0.063
E	1.95	2.00	2.05	0.077	0.079	0.081
E2	0.75	0.90	1.05	0.031	0.035	0.039
e	0.65 BSC.			0.026 BSC.		
L	0.20	0.30	0.40	0.008	0.012	0.016