

## MicroPower, Ultra-sensitive Hall Effect Switch

### ❖ GENERAL DESCRIPTION

AX8101/A is a three-terminal Hall Effect sensor device with a output driver, mainly designed for battery-operation, hand-held equipment (such as Cellular and Cordless Phone, PDA). After power-on, AX8101/A will detect and setup the operating pole (North or South) to avoid another side magnetic noise (**Patent pending**). For AX8101, the output will be turned off under no magnetic field. While the magnetic flux density (B) is larger than operate point (Bop), the output will be turned on; the output is latched until B is lower than release point (Brp).

### ❖ FEATURES

- Micro Power Operation for Battery Applications
- 2.4V to 5.5V battery operation
- Chopper Stabilized Technology
- Operation with North or South Pole
- High sensitivity and high stability of the magnetic switching points
- 3-pin SOT-23/Thin SOT-23 Pb-Free packages

### ❖ BLOCK DIAGRAM

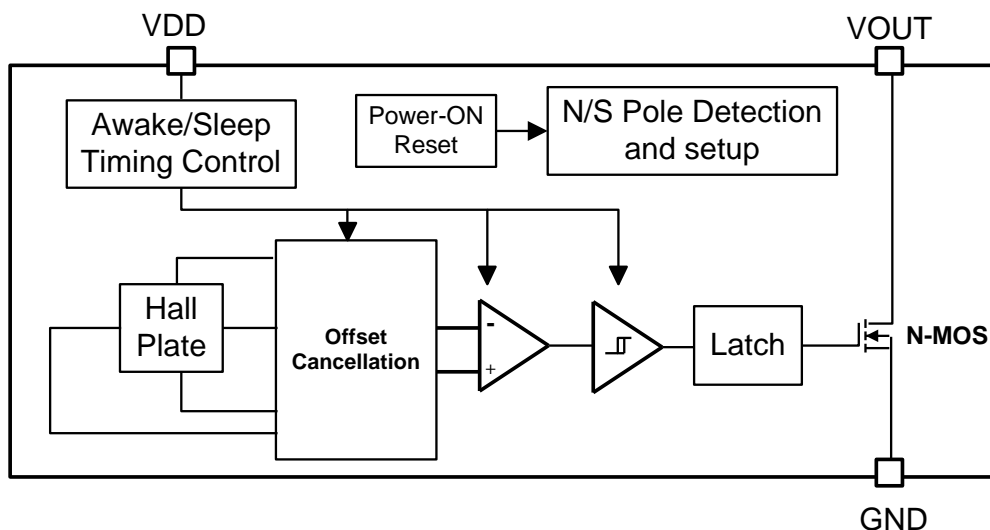

❖ PIN ASSIGNMET

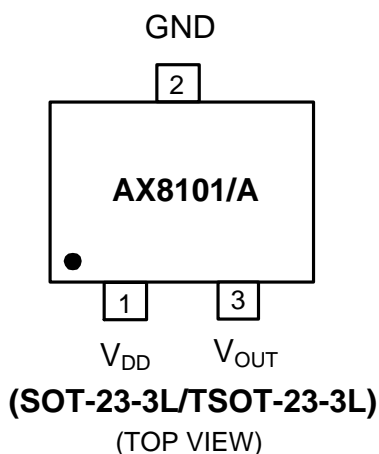

Name	Description
VDD	Power Input
GND	Ground
Output	AX8101: B>Bops or B<Bopn, Output is Low. B<Brps or B> Brpn, Output is High. AX8101A: B>Bops or B<Bopn, Output is High. B<Brps or B> Brpn, Output is Low.

❖ ORDER/MARKING INFORMATION

Order Information	Top Marking
<p style="text-align: center;"><b>AX8101 X XX X</b></p> <p>Output: Blank: Pull High, A: Pull Low            Package Type: R: SOT-23-3L, RT: TSOT-23-3L            Packing: Blank: Bag, A: Taping</p>	<p style="text-align: center;">LLYWX</p> <p>→ ID code: internal            WW: 01~26 (A~Z), 27~52 (a~z)            → Year: A =2010, 1 =2011            Identification code            H1: AX8101            H2: AX8101A</p>

❖ ABSOLUTE MAXIMUM RATINGS (at T<sub>A</sub>=25°C)

Characteristics	Symbol	Rating	Unit
VDD Pin Voltage	V <sub>DD</sub>	- 0.3 to 6V	V
Output Pin Voltage	V <sub>OUT</sub>	- 0.3 to 6V	V
Output Current	I <sub>OUT</sub>	2	mA
Storage Temperature Range	T <sub>ST</sub>	-65 to +150	°C
Junction Temperature	T <sub>J</sub>	+125	°C
Operating Temperature Range	T <sub>OP</sub>	-40 to +85	°C
Thermal Resistance from Junction to ambient	θ <sub>JA</sub>	550	°C/W
Power Dissipation [ PD=( T <sub>J</sub> -T <sub>A</sub> ) / θ <sub>JA</sub> ]	PD	230	mW

Note : θ<sub>JA</sub> is measured with the PCB copper area of approximately 1 in<sup>2</sup>(Multi-layer).

❖ ELECTRICAL CHARACTERISTICS

( $V_{DD} = 2.75V$ ,  $T_A=25^{\circ}C$ , unless otherwise specified)

Characteristics	Symbol	Conditions	Min	Typ	Max	Units
Supply Voltage	$V_{DD}$		2.4	-	5.5	V
Supply Current	$I_{DD}$	Awake state	-	2	4	mA
		Sleep state	-	7	12	uA
		Average	-	9	16	uA
Output Saturation Voltage	$V_{OSAT}$	$I_{OUT}=1mA$	-	0.1	0.3	V
Output Leakage Current	$I_{O-LEAK}$	$V_{OUT}=5.5V$ , $B < B_{rp}$	-	0.01	1	uA
Output Wake-Up Time	$T_{wake-up}$		-	70	120	us
Period	$T_{Period}$		-	70	120	ms
Duty Cycle	D.C		-	0.1	-	%
North or South Pole Detection and Setup Time	$T_{Set}$	Continuous $>B_{OPS}$ or $<B_{OPN}$	-	210	400	ms

❖ MAGNETIC CHARACTERISTICS

( $V_{DD} = 2.75V$ ,  $T_A=25^{\circ}C$ , unless otherwise specified)

Characteristics	Symbol	Conditions	Min	Typ	Max	Units
Operating Points	$B_{OPS}$		-	35	55	Gauss
	$B_{OPN}$		-55	-35	-	
Release Points	$B_{RPS}$		10	25	-	
	$B_{RPN}$			-25	-10	
Hysteresis	$B_{Hys}$		-	10	-	

1. AX8101:

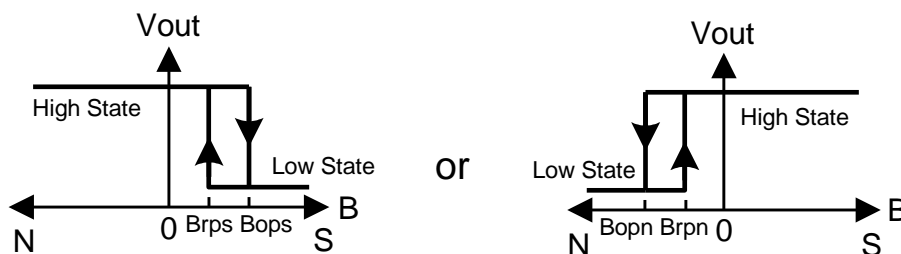

## 2. AX8101A:

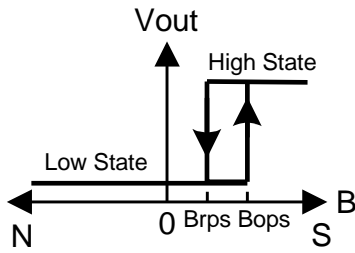

or

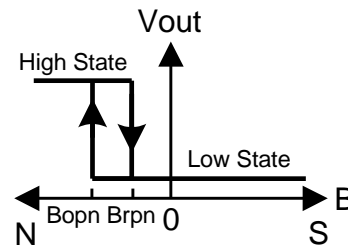
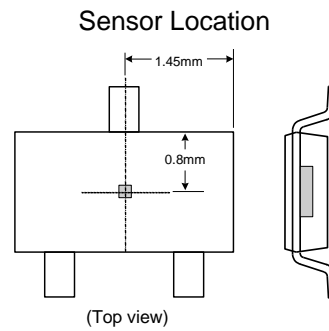
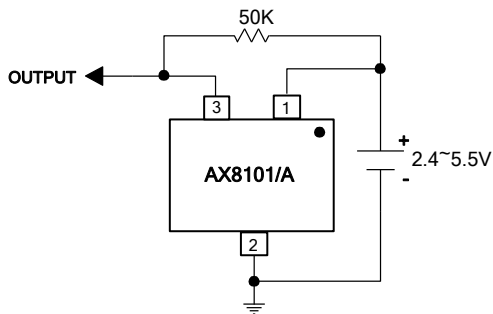
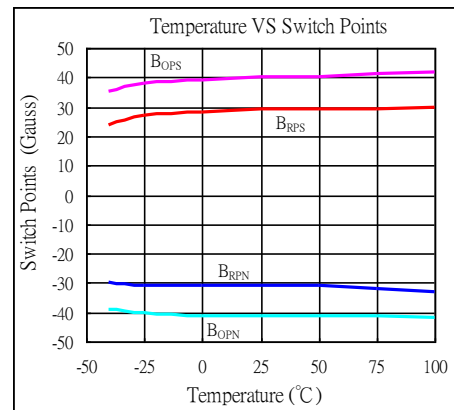
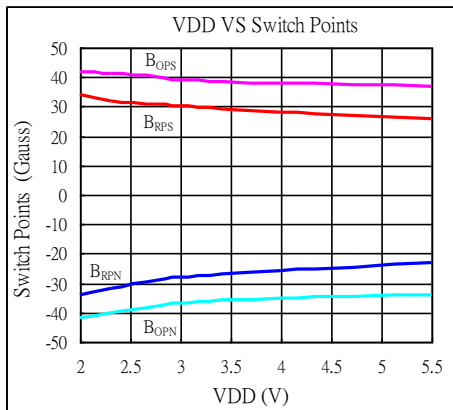
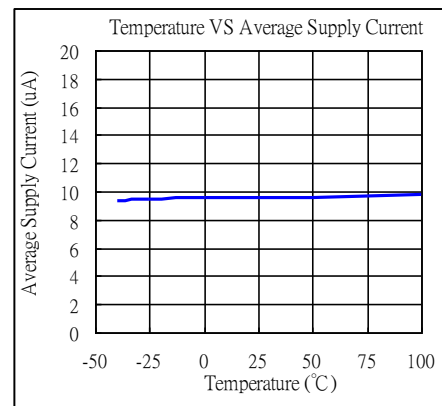
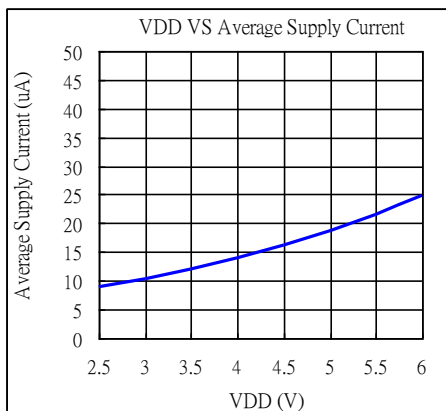
**❖ APPLICATION CIRCUIT**

**❖ TYPICAL CHARACTERISTICS**

❖ PACKAGE OUTLINES

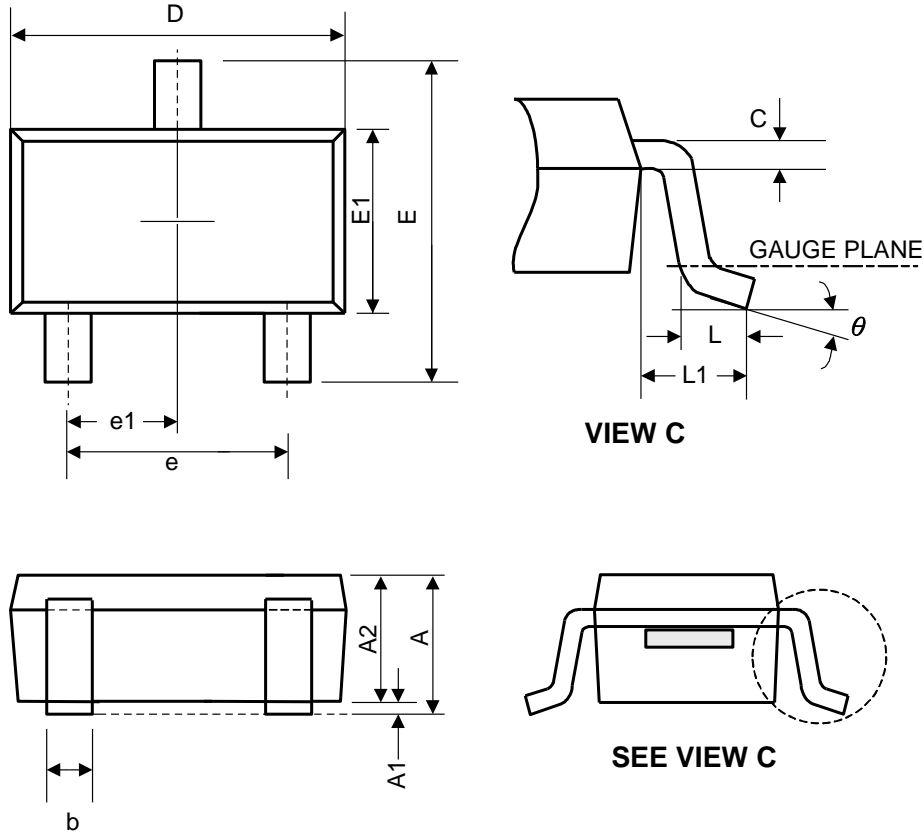
(1) SOT-23-3L



Symbol	Dimensions in Millimeters			Dimensions in Inches		
	Min.	Nom.	Max.	Min.	Nom.	Max.
A	-	-	1.45	-	-	0.057
A1	0.00	0.08	0.15	-	-	0.006
A2	0.90	1.10	1.30	0.035	0.043	0.051
b	0.30	0.40	0.50	0.012	0.016	0.020
C	0.08	0.15	0.22	0.003	0.006	0.009
D	2.70	2.90	3.10	0.106	0.114	0.122
E	2.60	2.80	3.00	0.102	0.110	0.118
E1	1.40	1.60	1.80	0.055	0.063	0.071
L	0.30	0.45	0.60	0.012	0.018	0.024
L1	0.50	0.60	0.70	0.020	0.024	0.028
e	1.9 BSC			0.075 BSC		
e1	0.95 BSC			0.037 BSC		
$\theta$	0°	4°	8°	0°	4°	8°

JEDEC outline: NA

(2) TSOT-23-3L

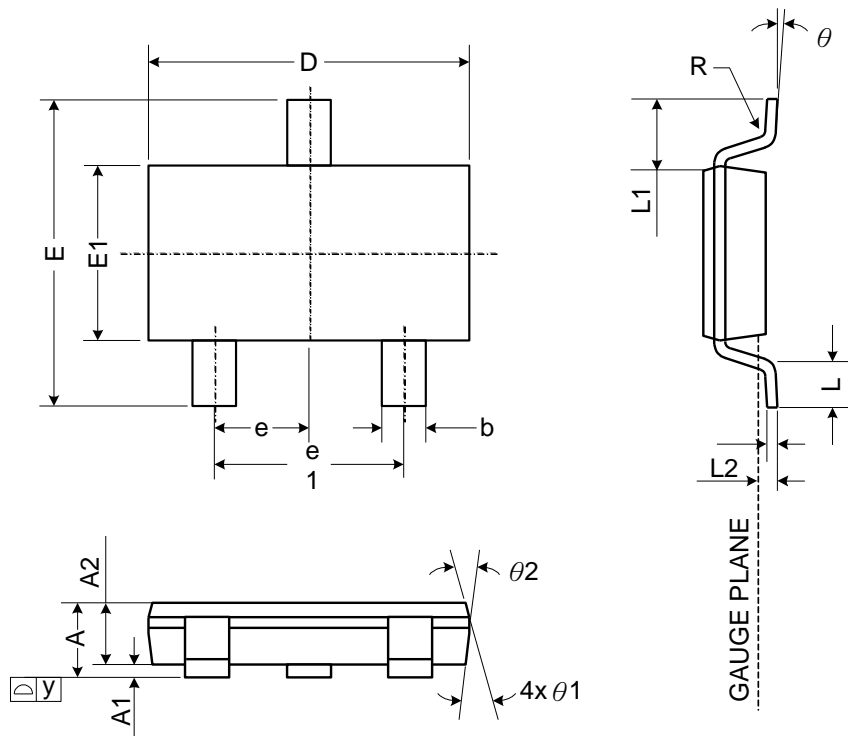

Symbol	Dimensions in Millimeters			Dimensions in Inches		
	Min.	Nom.	Max.	Min.	Nom.	Max.
A	0.75	-	0.90	0.030	-	0.035
A1	0.00	-	0.10	0.000	-	0.004
A2	0.70	0.75	0.80	0.028	0.030	0.031
b	0.35	-	0.51	0.014	-	0.020
C	0.10	-	0.25	0.004	-	0.010
D	2.80	2.90	3.00	0.110	0.114	0.118
E	2.60	2.80	3.00	0.102	0.110	0.118
E1	1.50	1.60	1.70	0.059	0.063	0.067
e	0.95 BSC.			0.037 BSC.		
e1	1.90 BSC.			0.075 BSC.		
L	0.37	-	-	0.015	-	-
L1	0.60 REF.			0.024 REF.		
L2	0.25 BSC.			0.010 BSC.		
y	-	-	0.10	-	-	0.004
R	0.10	-	-	0.004	-	-
theta	0°	-	8°	0°	-	8°
theta1	7° NOM.			7° NOM.		
theta2	5° NOM.			5° NOM.		