

## **Universal High Brightness Led Driver**

### **❖ GENERAL DESCRIPTION**

The AX9370 is a high performance LED lighting controller with PFC integrated which uses primary-side-control to eliminate opto-coupler and simplify the LED lighting driving system. AX9370 removes the need for secondary feedback circuitry while achieving excellent line regulation.

AX9370 integrates power factor correction function and works in boundary conduction mode (BCM) which can minimize the switching loss, thus increasing efficiency.

In a flyback circuit with the controller AX9370 at BCM operation can also reduce choke variation and enhance the LED current accuracy for line input voltage variation and output voltage variation.

Compared with a traditional LED driver IC, AX9370 can achieve the  $PF > 0.95$  and provide accurate constant current  $< \pm 5\%$  in a universal input voltage range (90VAC~264VAC).

Thus AX9370 is designed for lowering total costs, size, and components while simultaneously increasing efficiency and system reliability.

### **❖ FEATURES**

- Primary-side Feedback Constant Current Control
- Universal Rectified 90VAC to 264VAC Input Voltage Range
- Boundary Conduction Mode (BCM) Operation with PFC ( $> 0.95$ )
- Constant Current Control LED Driver ( $< \pm 5\%$ )
- Built-in Secondary Short Circuit Protection and Secondary Open Circuit Protection.
- Line Compensation
- Output Voltage Compensation
- LED Series/Parallel Combinations
- SOT-23-6L Package Available

**❖ BLOCK DIAGRAM**

Figure 1

**❖ PIN ASSIGNMENT**

The package of AX9370 is SOT-23-6L; the pin assignment is given by:

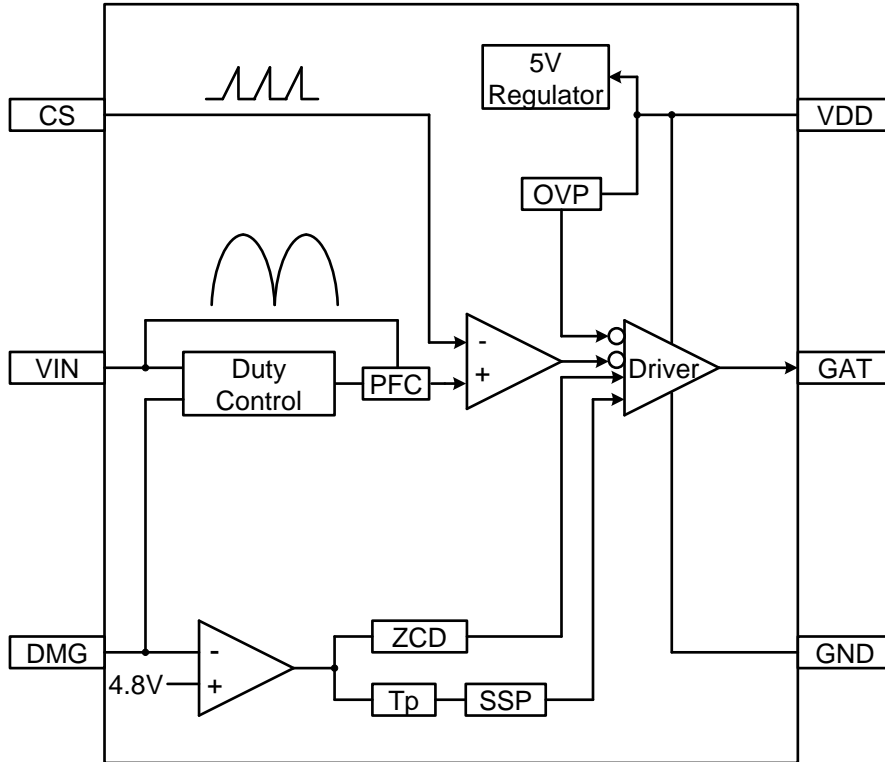
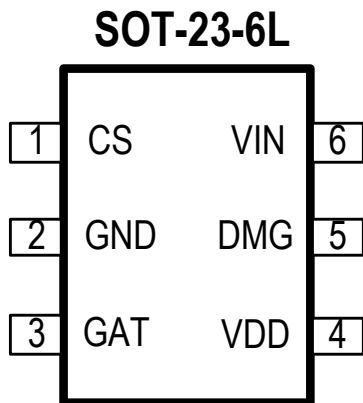

Name	Description
<b>CS</b>	Current sense
<b>GND</b>	Ground return for all internal circuitry
<b>GAT</b>	Gate driver output
<b>VDD</b>	Power supply pin for all internal circuit
<b>DMG</b>	This pin is zero current demagnetization sensing for transition-mode operation
<b>VIN</b>	This pin is connected to the rectified voltage to provides the sinusoidal reference

❖ ORDER/MARKING INFORMATION

Order Information	Top Marking
<p><b>AX9370XX</b></p> <p>Package: C: SOT-23-6L      Packing: Blank: Tube A : Taping</p>	<p><b>MMAYW</b> → WW:01~26 (A~Z) 27~52 (A~Z) Year: A=2011 B=2012 C=2013 : I=2019 Voltage Code</p> <p>AX9370</p>

❖ ABSOLUTE MAXIMUM RATINGS (at T<sub>A</sub>=25°C)

Characteristics	Symbol	Range	Unit
Power supply pin for all internal circuit	V <sub>DD</sub>	22	V
DMG voltage to GND	V <sub>DMG</sub>	-0.3 to V <sub>DD</sub>	V
VIN voltage to GND	V <sub>IN</sub>	-0.3 to V <sub>DD</sub>	V
CS voltage to GND	V <sub>CS</sub>	-0.3 to 5	V
GAT voltage to GND	V <sub>GAT</sub>	-0.3 to V <sub>DD</sub>	V
Operating junction temperature rang	T <sub>J</sub>	-40 to +150	°C
Operating ambient temperature rang	T <sub>OPA</sub>	-40 to +85	°C
Storage temperature rang	T <sub>STG</sub>	-65 to +150	°C
Lead temperature (Soldering 10 sec)	T <sub>LEAD</sub>	260	°C
Power dissipation @T <sub>A</sub> =25 °C	P <sub>D</sub>	0.3	W
Thermal resistance junction to ambient (Note 2)	θ <sub>JA</sub>	220	°C/W
Thermal resistance junction to colloid surface	θ <sub>JC</sub>	106.6	°C/W
ESD rating (Human body mode) (Note 3)	V <sub>ESD</sub>	2	kV

❖ RECOMMENDED OPERATING CONDITIONS

Characteristics	Symbol	Range	Unit
Supply voltage	V <sub>DD</sub>	16	V
VIN voltage to GND	V <sub>IN</sub>	-0.3 to 10.5	V
DMG voltage to GND	V <sub>DMG</sub>	-0.3 to 10.5	V
Ambient Temperature Range	T <sub>J</sub>	-40 to +125	°C
Supply voltage	T <sub>A</sub>	-40 to +85	°C

**Note 1:** Stresses listed as the above “Absolute Maximum Ratings” may cause permanent damage to the device. These are for stress ratings. Functional operation of the device at these or any other conditions beyond those indicated in the operational sections of the specifications is not implied. Exposure to absolute maximum rating conditions for extended periods may remain possibility to affect device reliability.

**Note 2:** Thermal Resistance is specified with the component mounted on a low effective thermal conductivity test board in free air at T<sub>A</sub>=25°C.

**Note 3:** Devices are ESD sensitive. Handling precaution recommended.

**Note 4:** The device is not guaranteed to function outside its operating conditions.

**❖ ELECTRICAL CHARACTERISTICS**

 (T<sub>A</sub>=25°C, unless otherwise noted)

Characteristics	Symbol	Condition	Min	Typ	Max	Unit
<b>V<sub>DD</sub> SECTION</b>						
V <sub>DD</sub> operation range	V <sub>DD</sub>	After turn-on	10	-	16	V
V <sub>DD</sub> turn-on threshold	V <sub>DD_ON</sub>		11	12	13	V
V <sub>DD</sub> turn-off threshold	V <sub>DD_OFF</sub>		8.5	9.5	10.5	V
V <sub>DD</sub> UVLO hysteresis	V <sub>UVLO_HY</sub>		-	2.5	-	V
Over voltage protection	OVP		17.4	18	18.6	V
Starting current	I <sub>ST</sub>		-	90	200	uA
Operation current	I <sub>OP</sub>	V <sub>DD</sub> =12 V C <sub>OUT</sub> = 1nF	-	1.8	-	mA
Quiescent Current	I <sub>q</sub>	During Protection	-	2.8	-	mA
<b>DEMAGNETIZATION SENSING FUNCTION</b>						
Input bias current	I <sub>DMG</sub>	V <sub>DMG</sub> > 5	-	6	15	μA
Source current	I <sub>DMG_SRC</sub>	V <sub>DMG</sub> = 0	-0.5	-1	-	mA
<b>LINE VOLTAGE SECTION</b>						
Linear operation range	V <sub>IN</sub>		-	0~10.5	-	V
<b>LINE VOLTAGE SECTION</b>						
Leading edge blanking time	T <sub>LEB</sub>		400	500	600	ns
<b>GATE DRIVER SECTION</b>						
Fall time	T <sub>f</sub>	V <sub>DD</sub> =16 V C <sub>OUT</sub> = 1nF	-	30	70	ns
Rise time	T <sub>r</sub>	V <sub>DD</sub> =16 V C <sub>OUT</sub> = 1nF	-	40	80	ns
Discharge peak current	I <sub>f_peak</sub>	V <sub>DD</sub> =16 V C <sub>OUT</sub> = 1nF	-	400	-	mA
Charge peak current	I <sub>r_peak</sub>	V <sub>DD</sub> =16 V C <sub>OUT</sub> = 1nF	-	-400	-	mA
Short circuit protective frequency	f <sub>SSP</sub>		3.8	4.8	5.8	kHz

## ❖ APPLICATION CIRCUIT

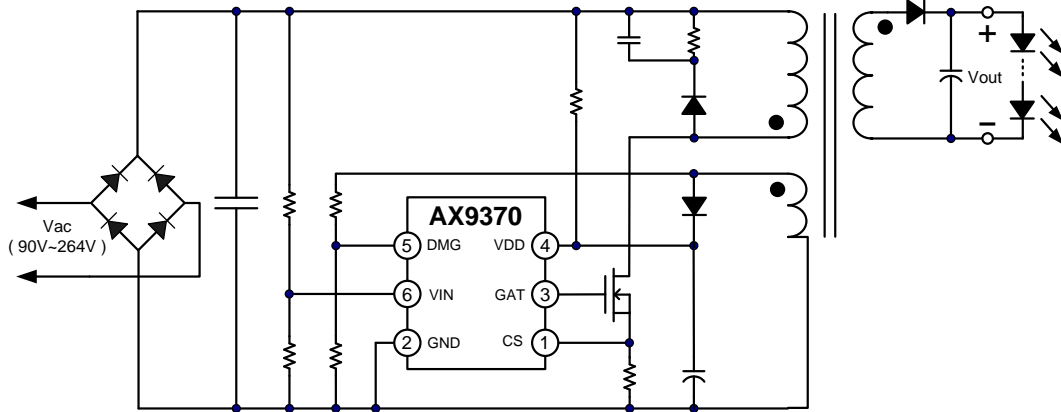

Figure 2

## ❖ APPLICATION INFORMATION

The AX9370 is a high performance LED lighting controller with PFC integrated which uses primary-side-control to eliminate opto-coupler and simplify the LED lighting driving system. AX9370 removes the need for secondary feedback circuitry while achieving excellent line regulation.

AX9370 integrates power factor correction function and works in boundary conduction mode which can minimize the switching loss, thus increasing efficiency.

### 1. CS Constant Current Settings

$$R_{CS} = \frac{N_1 \cdot K}{N_2 \cdot I_{OUT}} \times \eta$$

$K \cong 0.07$  :120Hz average constant

When  $R_{CS}$  is cut off, CS pin voltage will be pulled up to 5V and then trigger the protection mode.

### 2. VIN Input Voltage Sense

The VIN pin is used to achieve power factor compensation and the duty cycle calculation via feedback phase and the value of the input voltage.

The internal saturation voltage of this pin is 10.5V, if its voltage is over 10.5V, it will be non-linear modulation. Thus the linear operation range from 3 to 10.5V is recommended.

We recommended resistor value is 18.5k and 660k as a resistor divider.

### 3. DMG Zero Current Switching and Output Open Circuit Detection

The main functions are the detection of secondary zero current switching and the judgment of secondary short protection.

The internal saturation voltage of this pin is 10.5V, if its voltage is over 10.5V, it will be non-linear modulation. Thus the linear operation range from 7 to 10.5V is recommended.

We recommended resistor value is 82k and 39k as a resistor divider.

#### 4. SSP (Secondary Short Protection)

The DMG signal is used for zero voltage detection (ZCD) and secondary short protection (SSP).

When the system is at normal operation, shown in Figure 3.  $T_1$  is the period between gate pulling low and DMG signal raising to 4.8V. If  $T_1$  is smaller than a preset time  $T_P$ , the system will be judged in normal operation. If DMG signal gets a falling edge below 4.8V at  $T_2$ ,  $T_2$  can be determined for zero current detected time.



Figure 3

The DMG and MOSFET gate driving signals, show as figure 4, when the secondary side short circuit happens, this will cause a low output voltage, the DMG signal would not exceed 4.8V. When MOSFET gate driving signal turns off, the DMG signal will not be triggered after passing through preset time  $T_P$ , thus, the system will be determined for secondary short circuit by the controller. In the meantime, the controller AX9370 will turn on short circuit protection mode and drive a protective switching signal ( $f_P$ ) to turn on MOSFET.

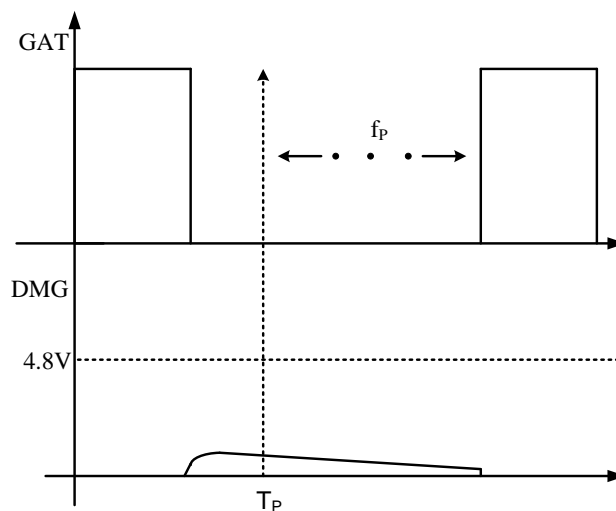

Figure 4

### 5. Start-up and SOP (Secondary Open Protection)

Start-up sequencing diagram as shown in figure 5. When  $V_{DD}$  is fully charged to 12V(UVLO-ON), the output voltage is still low, the DMG signal is similar to the signal which is in SSP mode.

Therefore, the controller AX9370 will turn on short circuit protection mode and drive a protective switching signal ( $f_P$ ) to turn on MOSFET. When the output voltage is high enough, the AX9370 will work in normal operation. The AX9370 incorporates an internal soft-start function. Once the  $V_{DD}$  pin voltage has reached its turn-on threshold, the AX9370 starts switching, but the switching frequency is in SSP mode.

The secondary open protection (SOP) of AX9370 is achieved by detecting the voltage of  $V_{DD}$ . When the voltage of  $V_{DD}$  reaches to 18V, the controller AX9370 will turn on open circuit protection mode and the MOSFET gate driving signal will stop completely. As a result, the  $V_{DD}$  can not be transferred energy by transformer, then, the voltage will drop. When  $V_{DD}$  drops below 16.5V, the system restarts again. If the secondary open protection (SOP) is released, AX9370 will return to normal operation.

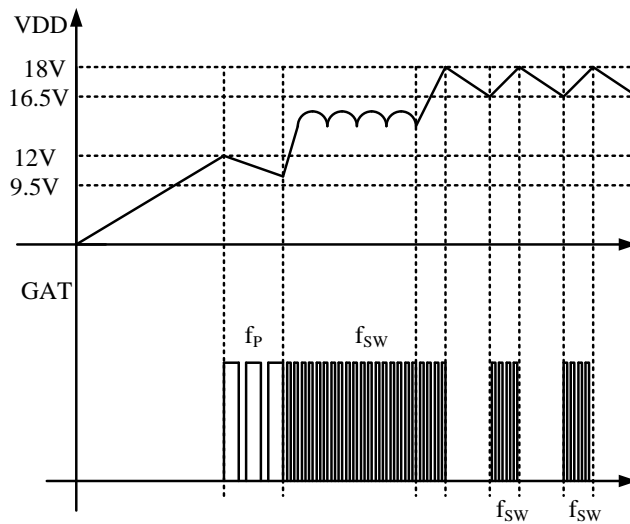

Figure 5

## 6. The Compensation of Line Regulation and Load Regulation

$$\frac{V_{OUT}}{V_{IN}} = \frac{N_2}{N_1} \frac{D}{1-D}; \quad D = \frac{N_1 V_{OUT}}{N_1 V_{OUT} + N_1 V_{IN}}$$

From above equations, the duty cycle is related to input voltage and output voltage.

In boundary conduction mode, even there is the same current control command; the average output current is still affected by the duty cycle. The VIN pin is the sense signal input representing the instantaneous rectified line voltage and the DMG pin is sense signal input from auxiliary winding which provides the secondary voltage feedback. So the system duty cycle can be led by these two feedback signals. Thus, the duty cycle can correct the current control command to compensate for line regulation and load regulation.

### VIN Pin

Increasing the ratio of voltage divider can lower the value of constant current in low line voltage or lower a small amount value of constant current in high line voltage. On the other hand, decreasing the ratio of voltage divider can raise the value of constant current in low line voltage or raise a small amount value of constant current in high line voltage.

### DMG Pin

Increasing the ratio of voltage divider can raise the value of constant current in low line voltage or raise a small amount value of constant current in high line voltage. On the other hand, decreasing the ratio of voltage divider can lower the value of constant current in low line voltage or lower a small amount value of constant current in high line voltage.

After adjusting the balance of current, following should be taken into consideration for adjusting the Rcs, which can compensate the increase or drop of current, however, Rcs would not affect the balance of current. During the process, the peak value of sine wave of VIN signal and the plateau of DMG signal must be within 7~10.5V.



## 7. Transformer Design

### (1) The Transformer Selection

$$P_{OUT} = \frac{1}{2} \times A_E$$

$A_E$ : the effective cross sectional core area

### (2) inductor current ripple

$$I_{AC(max)} = \frac{P_{OUT}}{V_{AC(min)} \times \eta}$$

$$I_{L(P-P)} = \frac{2 \times I_{AC(max)}}{D_{max}}$$

### (3) Inductor inductance

$$L_P = \frac{V_{AC(min)-Peak} \times D_{max}}{I_{L(P-P)} \times f_{SW}}$$

### (4) winding turns ratio

$$N_P = \frac{L \times I_{L(P-P)} \times 10^8}{A_E \times B_{max}}$$

$$N_S = \frac{V_{OUT} + V_D}{V_{AC(min)}} \times \frac{1-D}{D} \times N_P$$

$$N_A = \frac{V_{CC}}{V_{OUT}} \times N_S$$

### (5) Design Example

Demo board: output 18~24V/350mA

$$P_{OUT} = \frac{1}{2} \times A_E$$

$$A_E > 2 \times 24 \times 0.35 = 16.8$$

Choosing EE-16  $A_E=0.192 \text{ cm}^2$

$$I_{AC(max)} = \frac{P_{OUT}}{V_{AC(min)} \times \eta} = \frac{8.4}{90 \times 0.8} = 0.117 \text{ A}$$

$$I_{L(P-P)} = \frac{2 \times I_{AC(max)}}{D_{max}} = \frac{2 \times 0.117}{0.45} = 0.52 \text{ A}$$

Maximum turn on duty cycle ( $D_{max}$ ) is 0.45

$$L_P = \frac{V_{AC(min)-Peak} \times D_{max}}{I_{L(P-P)} \times f_{SW}} = \frac{90 \times 0.45}{0.52 \times 45 \times 10^3} = 1.73 \text{ mH}$$

The lowest switching frequency cannot be set lower than 22 kHz. However, if the frequency is set too high, there will be a concern issue with high line voltage. Normally setting is 30 ~ 45 kHz.

$$N_p = \frac{L \times I_{L(P-P)} \times 10^8}{A_E \times B_{\max}} = \frac{1.73 \times 10^{-3} \times 0.52 \times 10^8}{0.192 \times 3900 \times 0.7} = 170$$

In consideration of EMI and the coupling between the transformer primary side and the secondary side, flat winding is recommended. Here can choose 0.2 mm\*1 magnet wire to wind bobbin with full four winding layers for primary side. The turns are 150.

$$N_s = \frac{V_{OUT} + V_D}{V_{AC(\min)}} \times \frac{1 - D_{\max}}{D_{\max}} \times N_p$$

$$= \frac{21 + 0.7}{90 \times \sqrt{2}} \times \frac{1 - 0.45}{0.45} \times 150 = 31.25$$

Here can choose 0.3 mm\*1 magnet wire to wind bobbin with full three winding layers for secondary side. The turns are 30.

$$N_A = \frac{V_{CC}}{V_{OUT}} \times N_s = \frac{12}{24} \times 30 = 15$$

The turn ratio is 150:30:15

Check formula D

$$N_s = \frac{V_{OUT} + V_D}{V_{AC(\min)}} \times \frac{1 - D_{\max}}{D_{\max}} \times N_p$$

$$= 30 = \frac{21 + 0.7}{127} \times \frac{1 - D}{D} \times 150$$

$$D = 0.46$$

- ※ As shown in figure 6, to minimize the effect of the leakage inductance and EMI, the coupling between the transformer primary side and the secondary side should be as tight as possible.
- ※ As shown in figure 7, when using interleaved winding arrangement,  $N_a$  and  $N_s$  cannot be separated by inside shading.

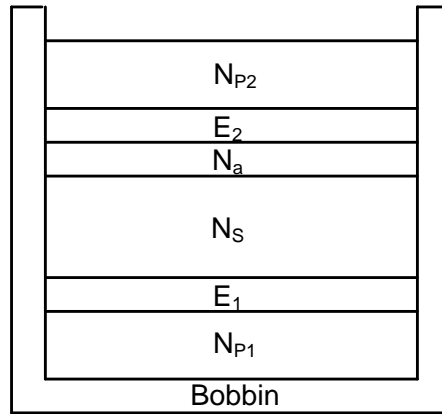

Figure 6

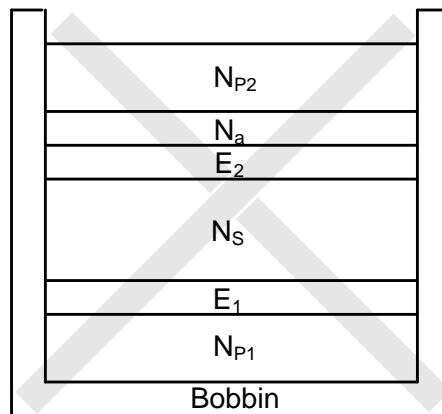
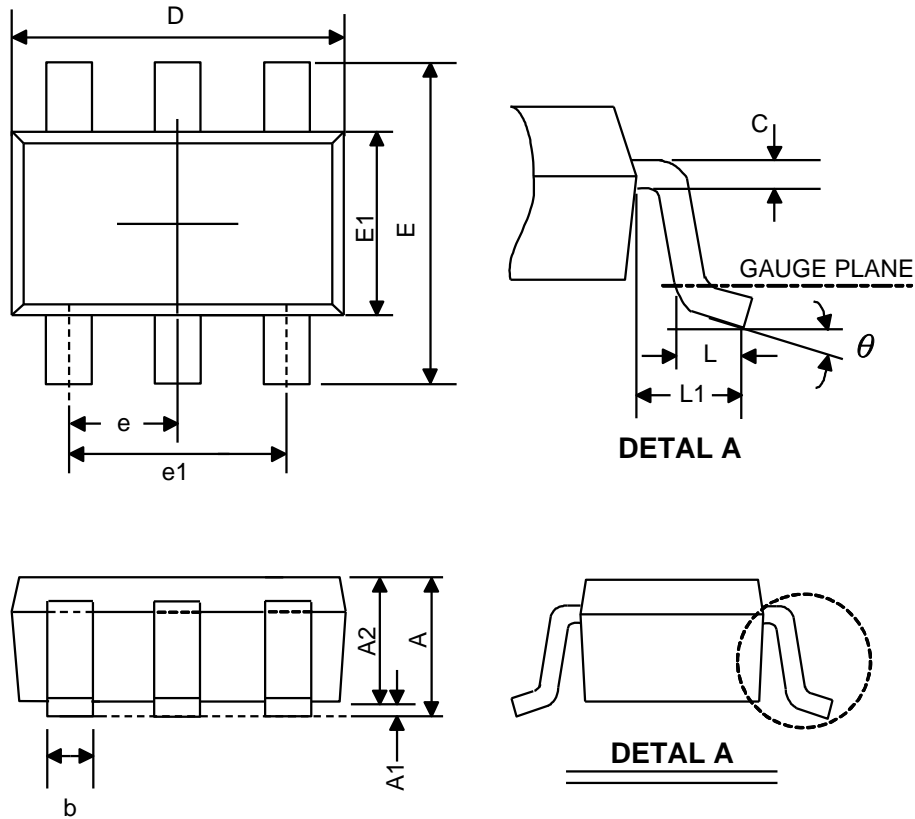

Figure 7

❖ PACKAGE OUTLINES



Symbol	Dimensions in Millimeters			Dimensions in Inches		
	Min.	Nom.	Max.	Min.	Nom.	Max.
A	-	-	1.45	-	-	0.057
A1	0.00	-	0.15	0	0.003	0.006
A2	0.90	1.10	1.30	0.035	0.043	0.051
b	0.30	0.40	0.50	0.012	0.016	0.020
C	0.08	-	0.22	0.003	0.006	0.009
D	2.70	2.90	3.10	0.106	0.114	0.122
E1	1.40	1.60	1.80	0.055	0.063	0.071
E	2.60	2.80	3.00	0.102	0.110	0.118
L	0.30	0.45	0.60	0.012	0.018	0.024
L1	0.50	0.60	0.70	0.020	0.024	0.028
e1	1.9 BSC			0.075 BSC		
e	0.95 BSC			0.037 BSC		
θ	0°	4°	8°	0°	4°	8°

JEDEC outline: MO-178 AB