

MicroPower, Ultra-sensitive Hall Effect Switch

❖ GENERAL DESCRIPTION

AZ8103/A is a three-terminal Hall Effect sensor device with a output driver, mainly designed for battery-operation, hand-held equipment (such as Cellular and Cordless Phone, PDA). For AZ8103, either north or South Pole of sufficient strength will turn the output on. The output will be turned off under no magnetic field. While the magnetic flux density (B) is larger than operate point (Bop), the output will be turned on (low), the output is latched until B is lower than release point (Brp), then turned off.

❖ FEATURES

- Micro Power Operation for Battery Applications
- 2.4V to 5.5V battery operation
- Chopper Stabilized Technology
- Operation with North or South Pole
- High sensitivity and high stability of the magnetic switching points
- 3-pin SOT-23/Thin SOT-23 and UDFN-3L (2X2) Pb-Free packages

❖ BLOCK DIAGRAM

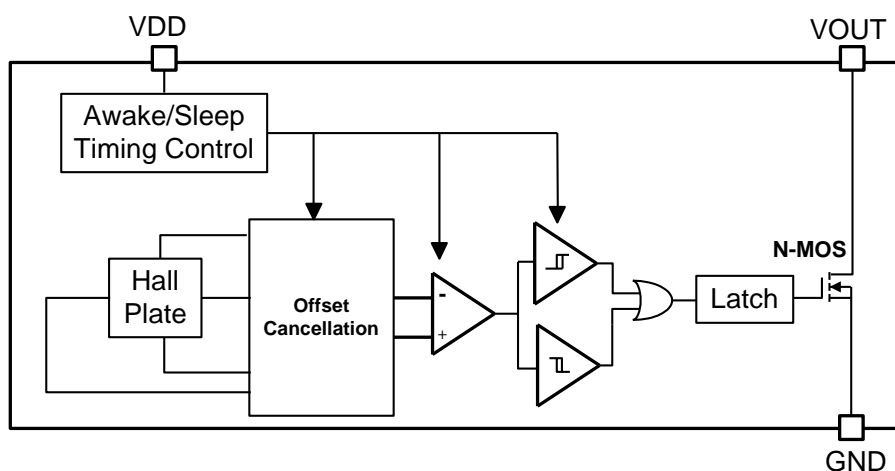

❖ ABSOLUTE MAXIMUM RATINGS (at $T_A=25^{\circ}\text{C}$)

Characteristics	Symbol	Rating	Unit
VDD Pin Voltage	V_{DD}	- 0.3 to 6V	V
Output Pin Voltage	V_{OUT}	- 0.3 to 6V	V
Output Current	I_{OUT}	2	mA
Power Dissipation	PD	$(T_J - T_A) / \theta_{JA}$	mW
Storage Temperature Range	T_{ST}	-65 to +150	$^{\circ}\text{C}$
Junction Temperature	T_J	+125	$^{\circ}\text{C}$
Operating Temperature Range	T_{OP}	-40 to +85	$^{\circ}\text{C}$
Thermal Resistance from Junction to case	SOT-23-3L	181	$^{\circ}\text{C/W}$
	TSOT-23-3L		
	UDFN-3L		
Thermal Resistance from Junction to ambient	SOT-23-3L	250	$^{\circ}\text{C/W}$
	TSOT-23-3L		
	UDFN -3L		

Note : θ_{JA} is measured with the PCB copper area of approximately 1 in²(Multi-layer).

❖ ELECTRICAL CHARACTERISTICS ($V_{DD} = 2.75\text{V}$, $T_A=25^{\circ}\text{C}$, unless otherwise specified)

Characteristics	Symbol	Conditions	Min	Typ	Max	Units
Supply Voltage	V_{DD}		2.4	-	5.5	V
Supply Current	I_{DD}	Awake state	-	2	4	mA
		Sleep state	-	7	12	μA
		Average	-	9	16	μA
Output Saturation Voltage	V_{OSAT}	$I_{OUT}=1\text{mA}$	-	0.1	0.3	V
Output Leakage Current	I_{O-LEAK}	$V_{OUT}=5.5\text{V}$, $B < Brp$	-	0.01	1	μA
Output Wake-Up Time	$T_{wake-up}$		-	70	120	μs
Period	T_{Period}		-	70	120	ms
Duty Cycle	D.C		-	0.1	-	%

❖ MAGNETIC CHARACTERISTICS ($V_{DD} = 2.75\text{V}$, $T_A=25^{\circ}\text{C}$, unless otherwise specified)

Characteristics	Symbol	Conditions	Min	Typ	Max	Units
Operating Points	B_{OPS}		-	35	55	Gauss
	B_{OPN}		-55	-35	-	
Release Points	B_{RPS}		10	25	-	
	B_{RPN}		-	-25	-10	
Hysteresis	B_{Hys}		-	10	-	

1. AZ8103:

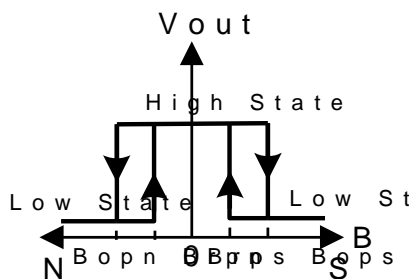

2. AZ8103A:

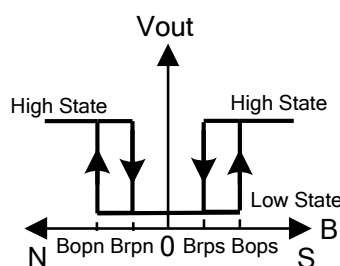

❖ APPLICATION CIRCUIT

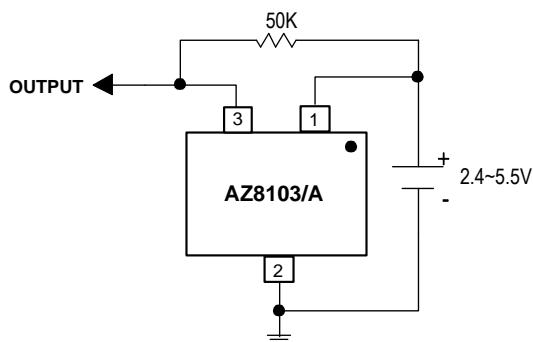

❖ SENSOR LOCATION

1. SOT-23-3L/TSOT-23-3L

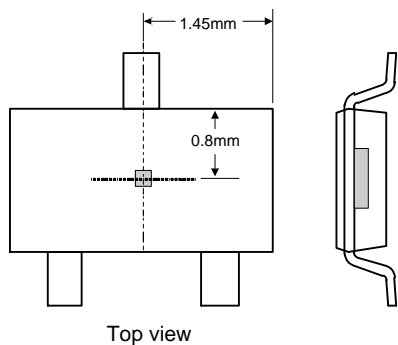

2. UDFN-3L

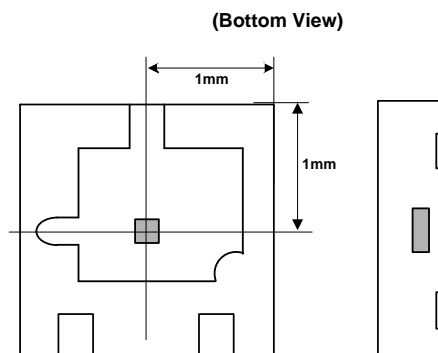

❖ TYPICAL CHARACTERISTICS

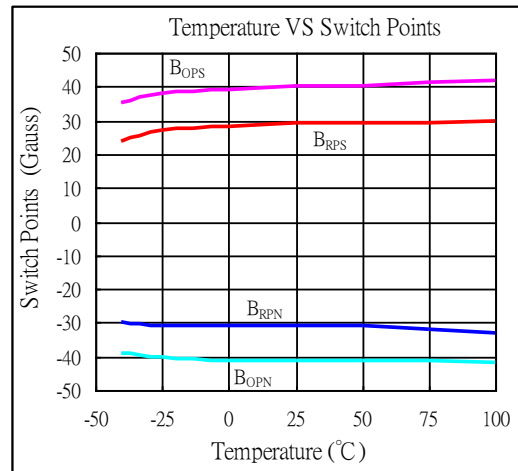
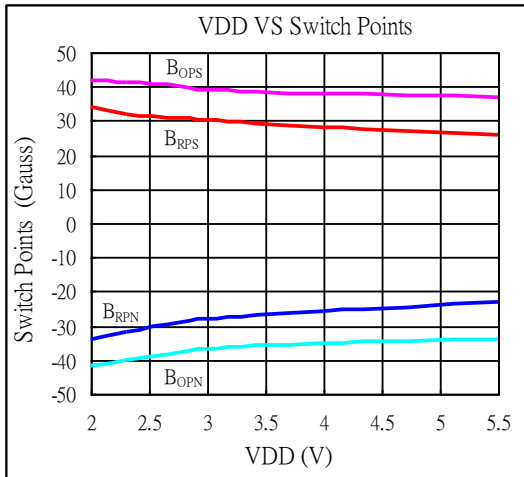
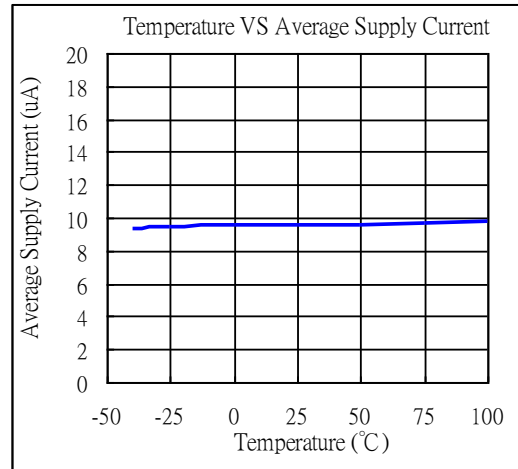
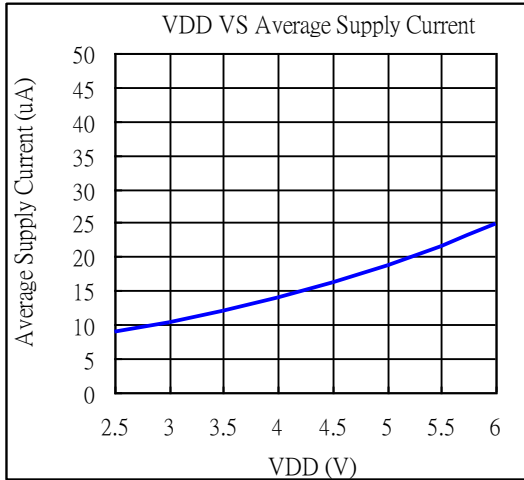

❖ PACKAGE OUTLINES

(1) SOT-23-3L

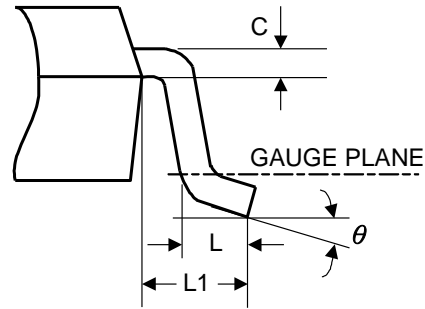
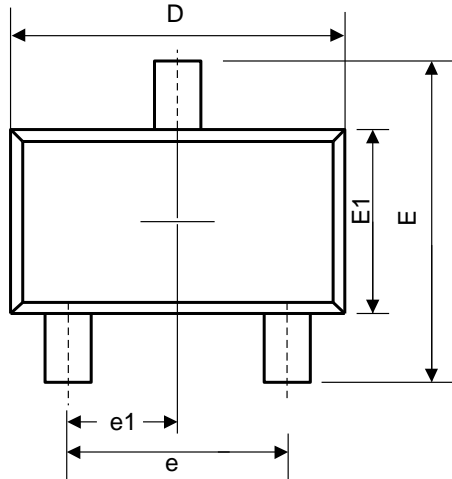

VIEW C

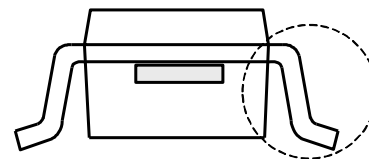
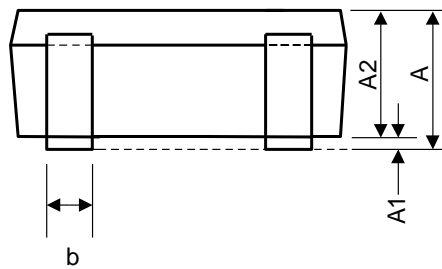

SEE VIEW C

Symbol	Dimensions in Millimeters			Dimensions in Inches		
	Min.	Nom.	Max.	Min.	Nom.	Max.
A	-	-	1.45	-	-	0.057
A1	0.00	0.08	0.15	-	-	0.006
A2	0.90	1.10	1.30	0.035	0.043	0.051
b	0.30	0.40	0.50	0.012	0.016	0.020
C	0.08	0.15	0.22	0.003	0.006	0.009
D	2.70	2.90	3.10	0.106	0.114	0.122
E	2.60	2.80	3.00	0.102	0.110	0.118
E1	1.40	1.60	1.80	0.055	0.063	0.071
L	0.30	0.45	0.60	0.012	0.018	0.024
L1	0.50	0.60	0.70	0.020	0.024	0.028
e	1.9 BSC			0.075 BSC		
e1	0.95 BSC			0.037 BSC		
θ	0°	4°	8°	0°	4°	8°

JEDEC outline: NA

(3) UDFN-3L (2X2X0.5mm)

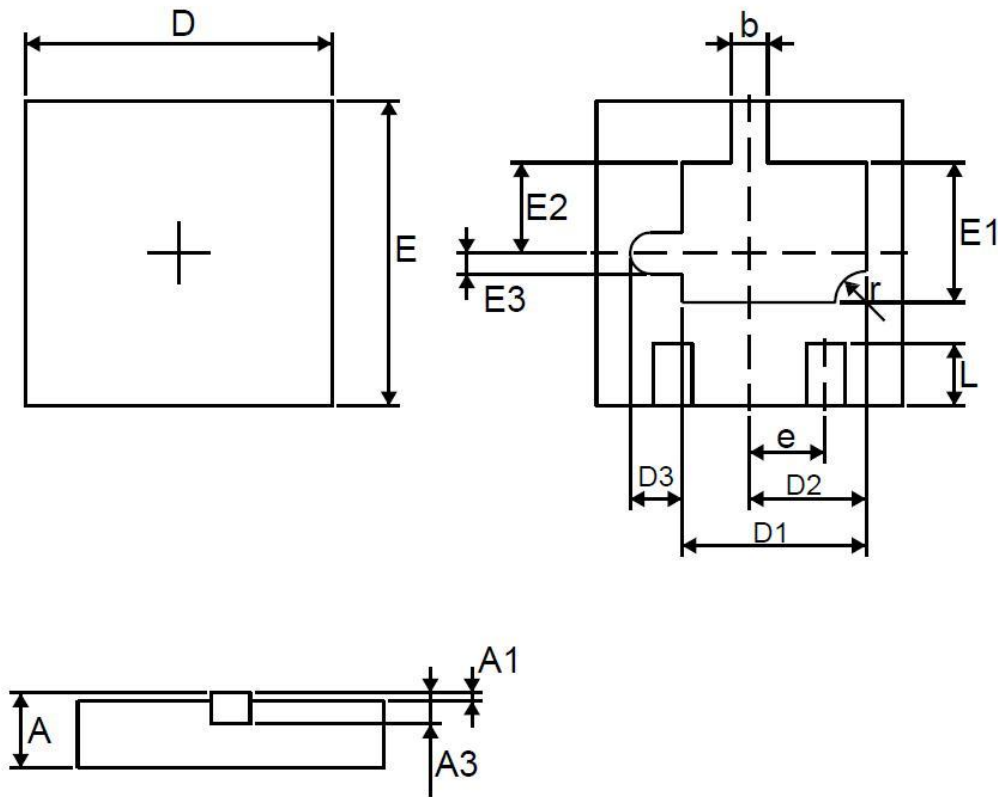

Symbol	Dimensions in Millimeters			Dimensions in Inches		
	Min.	Nom.	Max.	Min.	Nom.	Max.
A	0.450	-	0.550	0.018	-	0.022
A1	0.000	-	0.05	0.000	-	0.002
A3	0.152REF.			0.006REF.		
D	1.924	-	2.076	0.076	-	0.082
E	1.924	-	2.076	0.076	-	0.082
D1	1.100	-	1.300	0.043	-	0.051
D2	0.325REF.			0.030REF.		
D3	0.763REF.			0.013REF.		
E1	0.800	-	1	0.031	-	0.039
E2	0.600REF.			0.024REF.		
E3	0.138REF.			0.005REF.		
k	0.200MIN.			0.008MIN.		
b	0.200	-	0.300	0.008	-	0.012
e	0.500TYP.			0.020TYP.		
L	0.324	-	0.476	0.013	-	0.019
r	-	0.2	-	-	0.008	-