

PWM/VFM Step-Down DC/DC Controller

GENERAL DESCRIPTION

The PT1101 Series are CMOS-based PWM step-down DC/DC Controllers with low supply current. A low ripple, high efficiency step-down DC/DC converter can be easily composed of with additional several external components such as a power-transistor, an inductor, a diode and capacitors. Output voltage is fixed or can be adjusted with external resistors. (PWM/VFM alternative circuit is disabled in adjustable types)

The PT1101 Series consist of a PWM control circuit, a high precision band-gap voltage reference, a soft-start circuit, a protection circuit, a PWM/VFM alternative circuit, an oscillator, an error amplifier with internal compensation network and input/output voltage detection circuits.

With its internal state-of-art control algorithm, the PT1101 Series based DC/DC converter can achieve high performance while maintaining stability. For example, with its PWM/VFM alternative circuit, when the load current is small, the operation is automatically switched into the VFM mode to improve the efficiency. Further, if the term of maximum duty cycle keeps on a certain time, the embedded protection circuits restart the operation with soft-start and repeat until the maximum duty cycle condition is released. Finally, built-in UVLO function blocks potentially unstable output when the input voltage is equal or less than UVLO threshold and makes this IC standby for low power consumption.

FEATURES

- Wide Range Of Input Voltage: 2.5V~18V
- Built-in Soft-start and Protection Function
- High Efficiency: Typ. 90%
- Oscillation Frequency: 500kHz
- High Accuracy Output Voltage: $\pm 2\%$
- Low Temperature Coefficient of Output Voltage: Typ. $\pm 100\text{ppm}/^\circ\text{C}$
- Standby Current: Typ. $0.1\mu\text{A}$
- Output Voltage: Stepwise Setting with a step of 0.1V in the range of 1.2V to 6.0V as fixed voltage type. Reference Voltage of Adjustable type is 1.0V.
- Small Package: SOT-23-5
- CMOS Output Capability

APPLICATION

- Hand-held communication equipment, cameras, video instruments such as VCRs, camcorders
- Battery-powered equipment
- Household electrical appliances

BLOCK DIAGRAM

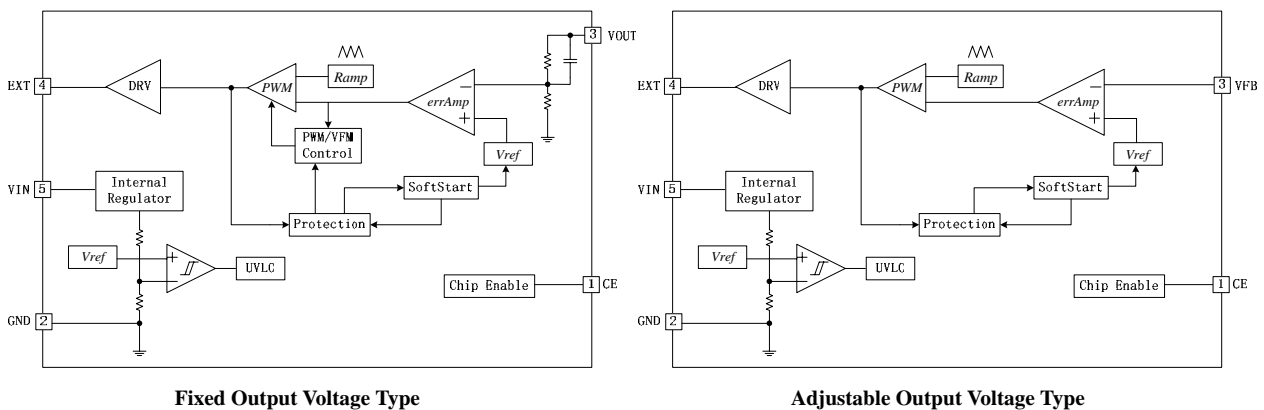

PWM/VFM Step-Down DC/DC Controller

ORDERING INFORMATION

In PT1101 series, the output voltage can be identified from its part number as shown below:

PT1101E23E-xx

↑

xx stands for output voltage

Note: As for adjustable output voltage type, xx equals to 10.

Package	Temperature	Part Number	Contents	Transport Media
SOT-23-5	-40°C to 125°C	PT1101E23E-10	Adjustable Output Voltage Without PWM/VFM alternative	Tape and Reel
		PT1101E23E-18	1.8V Fixed Output Voltage With PWM/VFM alternative circuit	Tape and Reel
		PT1101E23E-33	3.3V Fixed Output Voltage With PWM/VFM alternative circuit	Tape and Reel
		PT1101E23E-50	5.0V Fixed Output Voltage With PWM/VFM alternative circuit	Tape and Reel

PIN CONFIGURATION

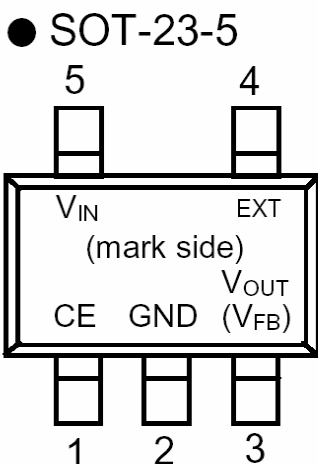

PIN DESCRIPTIONS

Names	Pin No.	Description
CE	1	Chip Enable. Active with "H"
GND	2	Ground
$V_{OUT}/(V_{FB})$	3	Output Voltage (Feedback Voltage for adjustable output voltage type)
EXT	4	External Transistor Driver Pin (CMOS output)
V_{IN}	5	Power Supply

PWM/VFM Step-Down DC/DC Controller
ABSOLUTE MAXIMUM RATINGS

Symbol	Parameter	Value	Unit
V_{IN}	V_{IN} Supply Voltage	20	V
V_{EXT}	Ext Pin Output Voltage	-0.3~ $V_{IN} + 0.3$	V
V_{CE}	CE Pin Input Voltage	-0.3~ $V_{IN} + 0.3$	V
$V_{OUT} / (V_{FB})$	$V_{OUT} / (V_{FB})$ PIN Input Voltage	-0.3~6	V
I_{EXT}	Ext Pin Output Current	±50	mA
PD	Power Dissipation	250	mW
T_{OPT}	Operation Temperature Range	-40~85	°C
T_{STG}	Storage Temperature Range	-55~125	°C

RECOMMENDED OPERATING RANGE

Symbol	Parameter	Value	Unit
V_{IN}	V_{IN} Supply Voltage	2.5~18	V
V_{EXT}	Ext Pin Output Voltage	-0.3~ $V_{IN} + 0.3$	V
V_{CE}	CE Pin Input Voltage	-0.3~ $V_{IN} + 0.3$	V
$V_{OUT} / (V_{FB})$	$V_{OUT} / (V_{FB})$ PIN Input Voltage	-0.3~5.5	V
I_{EXT}	Ext Pin Output Current	±50	mA

ELECTRICAL CHARACTERISTICS
PT1101E23E-10, Adjustable Output Voltage Type

Parameter	Symbol	Conditions	Min.	Typ.	Max.	Units
Operating Voltage	V_{IN}		2.5		18	V
Feedback Voltage	V_{FB}	$V_{IN}=V_{CE}=8V, I_{FB}=350mA$	0.98	1.00	1.02	V
Feedback Voltage Temperature coefficient	$\frac{\Delta V_{FB}}{\Delta T}$	-40°C < T_{OPT} < 85°C		±100		ppm/°C
Supply Current	I_{Q1}	$V_{IN}=V_{CE}=18V, V_{FB}=2V$		40	80	μA
Shutdown Current	I_{Q2}	$V_{IN}=18V, V_{CE}=V_{FB}=0V$		0.1	1	μA
Oscillator Frequency	f_{OSC}	$V_{IN}=V_{CE}=8V, I_{FB}=350mA$	400	500	600	kHz
Maximum Duty Cycle	D_{MAX}		100			%
Minimum Duty Cycle	D_{MIN}				0	%
EXT “H” Output Current	I_{EXTH}	$V_{IN}=V_{CE}=8V, V_{EXT}=7.9V, V_{FB}=3V$		-17	-10	mA
EXT “L” Output Current	I_{EXTL}	$V_{IN}=V_{CE}=8V, V_{EXT}=0.1V, V_{FB}=0V$	20	30		mA
CE “H” Input Voltage	V_{CEH}	$V_{IN}=8V, V_{FB}=0V$	1.5			V

PWM/VFM Step-Down DC/DC Controller

CE “H” Input Voltage	V_{CEL}				0.3	V
UVLO Voltage	V_{UVLO1}	$V_{IN}=V_{CE}=2.5V \rightarrow 1.5V, V_{FB}=0V$	1.7	2.0	2.4	V
UVLO Release Voltage	V_{UVLO2}	$V_{IN}=V_{CE}=1.5V \rightarrow 2.5V, V_{FB}=0V$		$V_{UVLO1}+0.1$	2.5	V
Delay time by soft-start	T_{SST}	$V_{IN}=8V, I_{FB}=10mA, V_{CE}=0V \rightarrow 2.5V$	5	10	20	ms
Delay time by Protection	T_{PROT}	$V_{IN}=V_{CE}=2.5V, V_{FB}=2.5V \rightarrow 0V$	5	15	30	ms

PT1101E23E-xx, Fixed Output Voltage Type

Parameter	Symbol	Conditions	Min.	Typ.	Max.	Units
Operating Voltage	V_{IN}		2.5		18	V
Feedback Voltage	V_{FB}	$V_{IN}=V_{CE}=V_{SET}+1.5V, I_{OUT}=100mA$	$V_{SET} \times 0.98$	V_{SET}	$V_{SET} \times 1.02$	V
Feedback Voltage Temperature coefficient	$\frac{\Delta V_{FB}}{\Delta T}$	$-40^{\circ}C < T_{OPT} < 85^{\circ}C$		± 100		ppm/ °C
Supply Current	I_{Q1}	$V_{IN}=V_{CE}=18V, V_{OUT}=V_{SET}+1.5V$		40	80	μA
Shutdown Current	I_{Q2}	$V_{IN}=18V, V_{CE}=V_{OUT}=0V$		0.1	1	μA
Oscillator Frequency	f_{OSC}	$V_{IN}=V_{CE}=V_{SET}+1.5V, I_{OUT}=100mA$	400	500	600	kHz
Maximum Duty Cycle	D_{MAX}		100			%
EXT “H” Output Current	I_{EXTH}	$V_{IN}=V_{CE}=8V, V_{EXT}=7.9V, V_{OUT}=V_{SET}+1.5V$		-17	-10	mA
EXT “L” Output Current	I_{EXTL}	$V_{IN}=V_{CE}=8V, V_{EXT}=0.1V, V_{OUT}=0V$	20	30		mA
CE “H” Input Voltage	V_{CEH}	$V_{IN}=8V, V_{OUT}=0V$	1.5			V
CE “H” Input Voltage	V_{CEL}				0.3	V
VFM Duty Cycle	VFMdty			35		%
UVLO Voltage	V_{UVLO1}	$V_{IN}=V_{CE}=2.5V \rightarrow 1.5V, V_{OUT}=0V$	1.7	2.0	2.4	V
UVLO Release Voltage	V_{UVLO2}	$V_{IN}=V_{CE}=1.5V \rightarrow 2.5V, V_{OUT}=0V$		$V_{UVLO1}+0.1$	2.5	V
Delay time by soft-start	T_{SST}	$V_{IN}=V_{SET}+1.5V, I_{OUT}=10mA, V_{CE}=0V \rightarrow V_{SET}+1.5V$	5	10	20	ms
Delay time by Protection	T_{PROT}	$V_{IN}=V_{CE}=V_{SET}+1.5V, V_{OUT}=V_{SET}+1.5V \rightarrow 0V$	5	15	30	ms

PWM/VFM Step-Down DC/DC Controller

TYPICAL APPLICATION

- PT1101E23E-10, Adjustable Output Voltage Type. For example, Output Voltage=3.2V

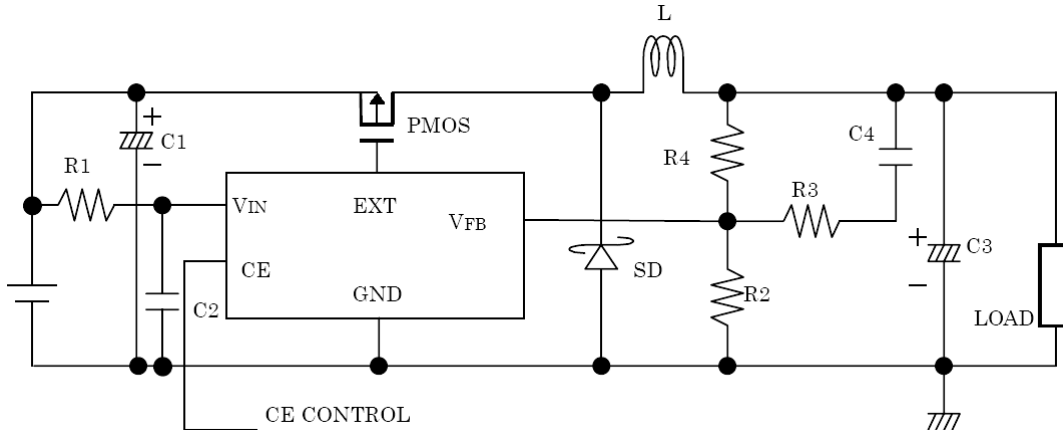

- | | | |
|-------------------------------|-------------------------------------|-------------------------------|
| PMOS: IRF7406 (IR) | L: CR105-270MC (Sumida, 27 μ H) | SD1: RB063L-30(Rohm) |
| C3: 47 μ F, Tantalum Type | C1: 10 μ F, Ceramic Type | C2: 0.1 μ F, Ceramic Type |
| C4: 1000pF, Ceramic Type | R1: 10 Ω | R2: 10k Ω |
| R3: 2.7 k Ω | R4: 22 k Ω | |

- PT1101E23E-xx, Fixed Output Voltage Type

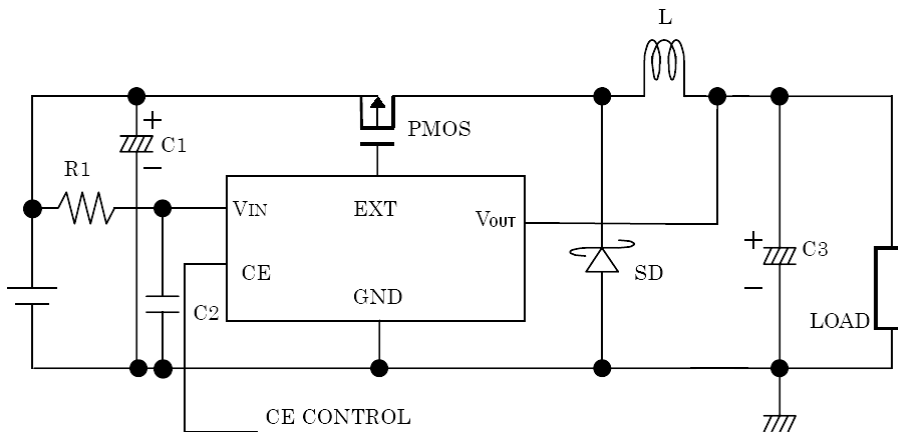

- | | | |
|-------------------------------|-------------------------------------|-------------------------------|
| PMOS: IRF7406 (IR) | L: CR105-270MC (Sumida, 27 μ H) | SD1: RB063L-30(Rohm) |
| C3: 47 μ F, Tantalum Type | C1: 10 μ F, Ceramic Type | C2: 0.1 μ F, Ceramic Type |
| R1: 10 Ω | | |

PWM/VFM Step-Down DC/DC Controller

APPLICATION INFORMATION

- To avoid parasitic current into each pin, make sure voltage applied to CE pin should be no more than the voltage level of VIN pin.
- The protection circuit may work if the term of maximum duty cycle continues for a certain time. As the result, V_{OUT} will be reset and settled by soft start operation until the maximum duty cycle condition is released. Be aware that if the differential voltage between VIN and VOUT is quite small, protection function may be triggered.
- Use schottky diode for high switching speed application. Pay attention to its current capability.
- Do not apply PT1101 to the condition with VIN is equal or less than minimum operation voltage.
- If the ratio of output voltage against input voltage is 35% or less while heavily loaded, PT1101E23E-xx keeps its VFM mode for low frequency operation. Therefore the output ripple voltage may be large. The phenomena are the typical characteristics of the PWM/VFM alternative circuit.
- To adjust output voltage when using PT1101E23E-10, follow the equation shown below, in which V_{FB} is equal to 1V.

$$V_{OUT} = V_{FB} \times \frac{R2 + R4}{R2}$$

Thus, with changing the value of R2 and R4, output voltage can be set in the specified range.

- To provide enough Phase Margin for stable operation, some critical components associated with local compensation network formed by R4 and C4 should be chosen correctly. Following procedure can help to find the suitable value of R and C.

Firstly, find the double pole caused by L and C3.

$$f_{POLE} = \frac{1}{2\pi\sqrt{L \cdot C3}}$$

Next, place a zero formed by R4 and C4 as much as f_{POLE} .

$$f_{ZERO} = \frac{1}{2\pi\sqrt{R4 \cdot C4}}$$

Finally, choose R3 about one tenth of R4 for noise attenuation on feedback path.

For example, if L=27μH, C3=47μF, the cut off frequency of the pole is approximately 4.5kHz. Choose R4=33kΩ and C4=1000pF to meet with compensation requirement. If VOUT is set to 2.5V, R2=22kΩ is appropriate. R3 can be set to one tenth of R4, that is, 3 kΩ.

OPERATION DESCRIPTION

The power stage of PWM step-down DC/DC converter can be seen as an input voltage chopping circuit followed by an L-C filter. Unlike the linear regulator which operates the power transistor in the linear mode, the PWM switching regulator operates the power transistor either in saturation or cutoff regions. Due to the voltage-ampere product of power transistor under these two operation modes keeps low, high efficiency can be easily achieved.

PWM/VFM Step-Down DC/DC Controller

The DC input voltage is firstly chopped into square waves whose magnitude is the same as input voltage and whose duty cycle is manipulated by the switching regulator controller, hereby is PT1101. With the use of following appropriately chosen L-C filter, such square wave modulation could be eliminated and ripple free DC voltage equal to the average of the duty cycle modulated DC input voltage results. The regulated output voltage is maintained by the controller, which operates much like a linear style controller. That is, by sensing the DC output and controlling duty cycle in a negative-feedback loop, the DC output could be regulated against input line and output load changes.

The operation of step-down DC/DC converter can be understood by braking its operation into two period. When the switch is turned on, the input voltage is presented to the L-C filter, the inductor current (i_1) ramps linearly upward from I_{Lmin} to I_{Lmax} and stores energy in itself. When the switch is turned off, the input voltage to inductor flies below ground and the schottky diode becomes forward biased. This continues to conduct current (i_2) which is formerly flowing through switch and some of the stored energy is discharged to load. Therefore a local current loop including diode, inductor and load comes into being.

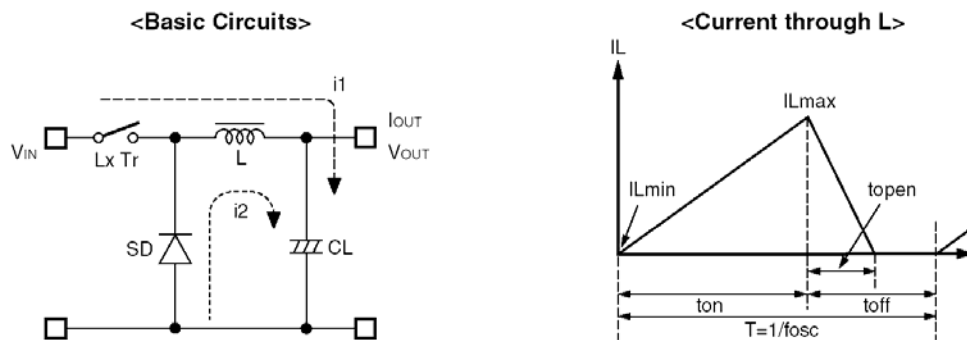

EXTERNAL COMPONENTS

- **Inductor**
Select an inductor that peak current does not exceed I_{Lmax} .
For constant load current, the smaller inductor value, the larger output ripple voltage.
- **Diode**
Use a diode with low V_F (Schottky diode is recommended) and high switching frequency. Reverse voltage rating should be more than V_{IN} and current rating should be larger than I_{Lmax} .
- **Capacitors**
As for V_{IN} , use a $10\mu F$ capacitor with low ESR for stable operation.
 C_{OUT} can reduce output ripple voltage, therefore a $47\mu F$ or more tantalum type capacitor is recommended.
- **Power Transistor**
Pch power MOSFET is required for PT1101.
Its breakdown voltage between gate and source should be a few higher than V_{IN} .
If heavily loaded, choose MOSFET with low $R_{DS(on)}$ for good efficiency.
If lightly loaded, choose MOSFET with low gate capacitance for good efficiency.
Current rating of power MOSFET should be larger than I_{Lmax} .

TYPICAL PERFORMANCE CHARACTERISTICS

Note: Typical characteristics are obtained with using the following components:

PMOS: IRF7406 (IR)	L: CR105-270MC (Sumida, 27 μ H)	SD1: SS24
C3: 47 μ F, Tantalum Type	C1: 10 μ F, Ceramic Type	C2: 0.1 μ F, Ceramic Type
C4: 1000pF, Ceramic Type	R1: 10 Ω	R2: 10k Ω
R3: 2.7 k Ω	R4: 22 k Ω	

1. Output Voltage vs. Output Current

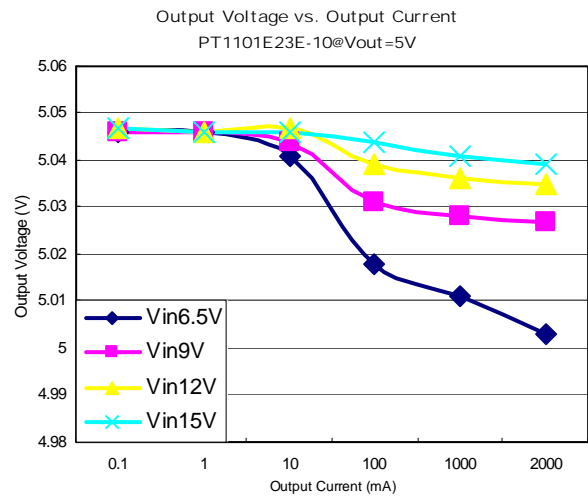
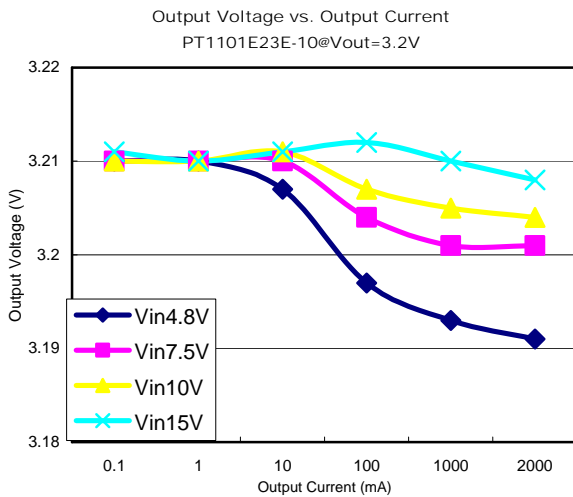

2. Efficiency vs. Output Current

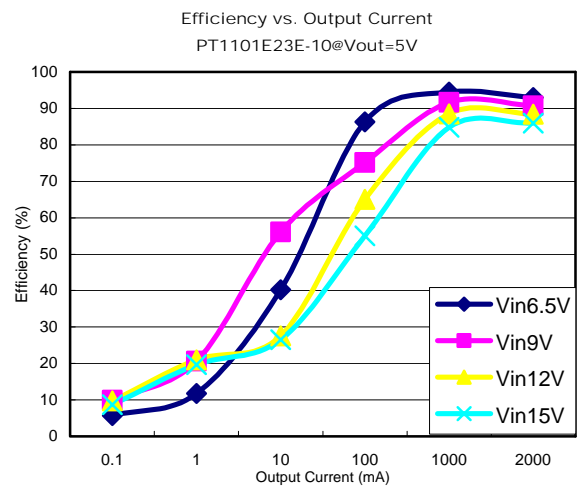
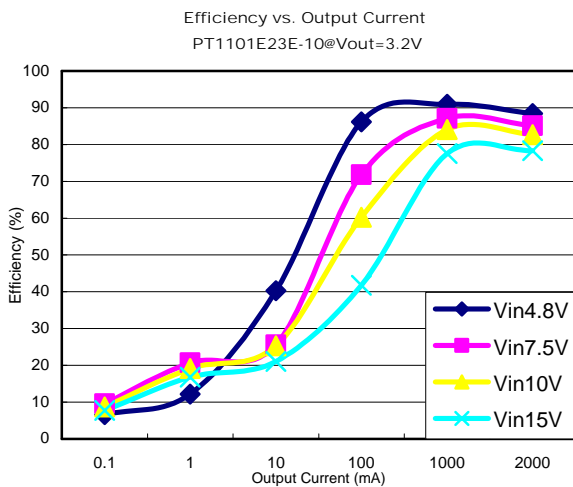

PWM/VFM Step-Down DC/DC Controller

3. Ripple Voltage vs. Output Current

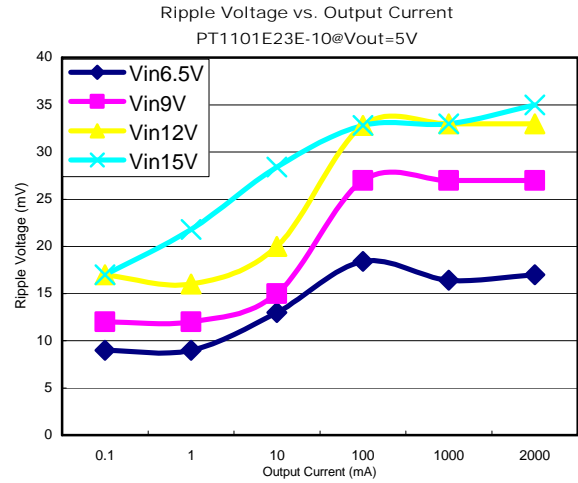
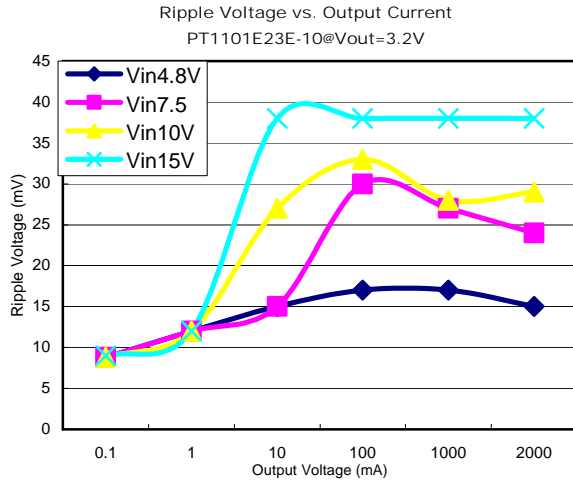

4. Output Voltage vs. Input Voltage

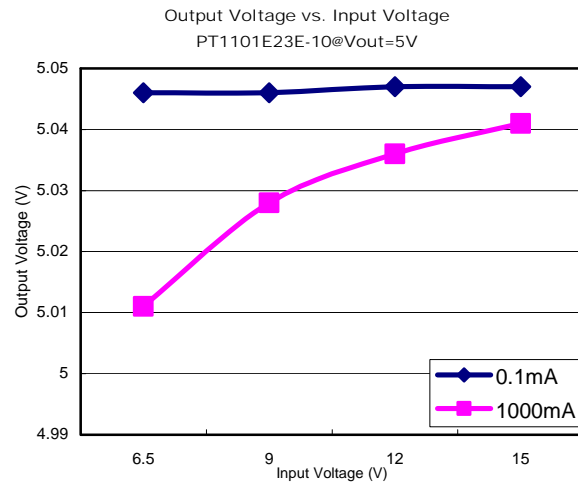
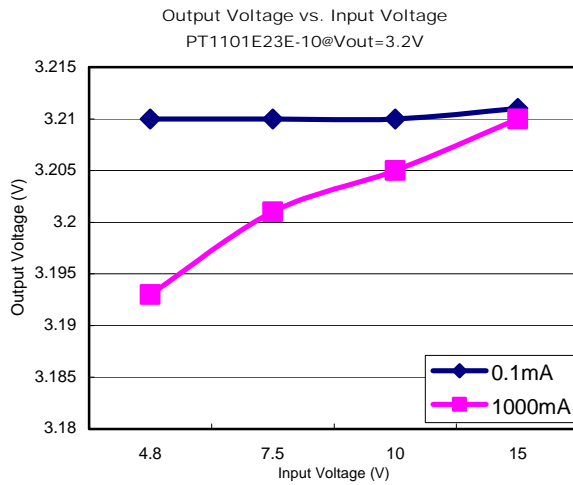

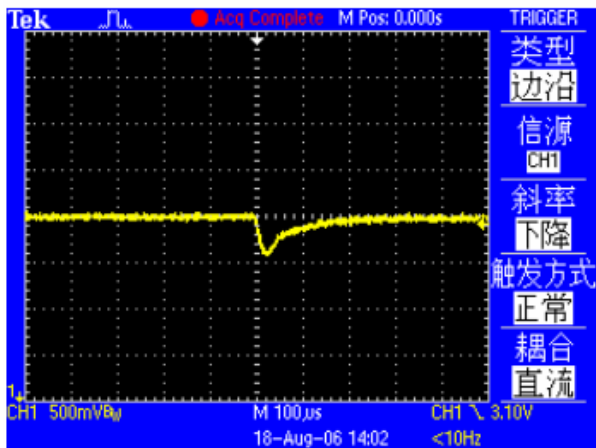
PWM/VFM Step-Down DC/DC Controller
5. Load Transient Response

Vin=4.8V, Vout=3.2V, L=27µH, C=47µF

I_{Load} 0 -> 1A

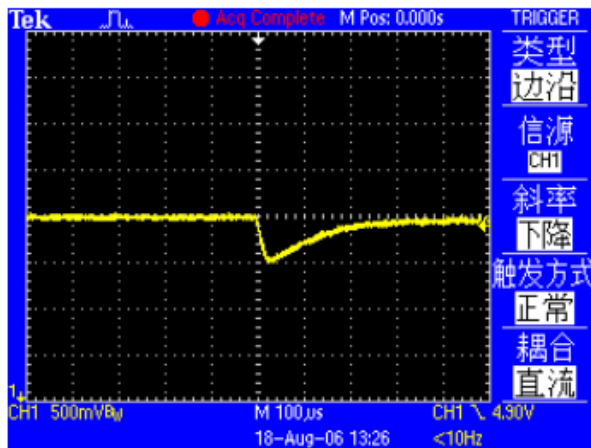

Vin=6.5V, Vout=5V, L=27µH, C=47µF

I_{Load} 0 -> 1A

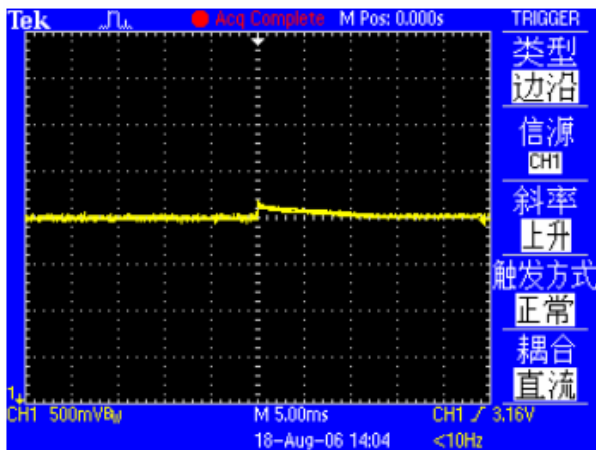

Vin=4.8V, Vout=3.2V, L=27µH, C=47µF

I_{Load} 1A -> 0A

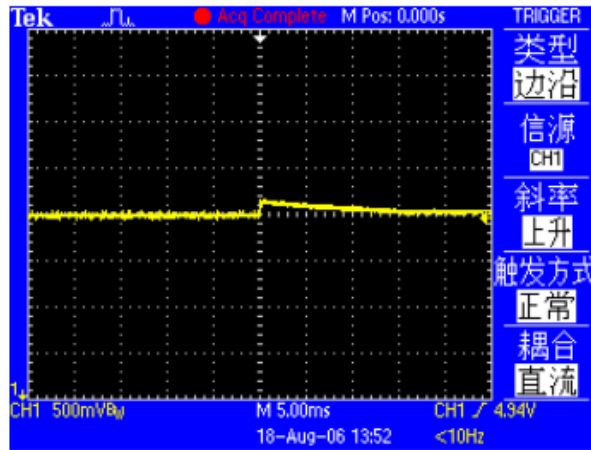

Vin=6.5V, Vout=5V, L=27µH, C=47µF

I_{Load} 1A -> 0A

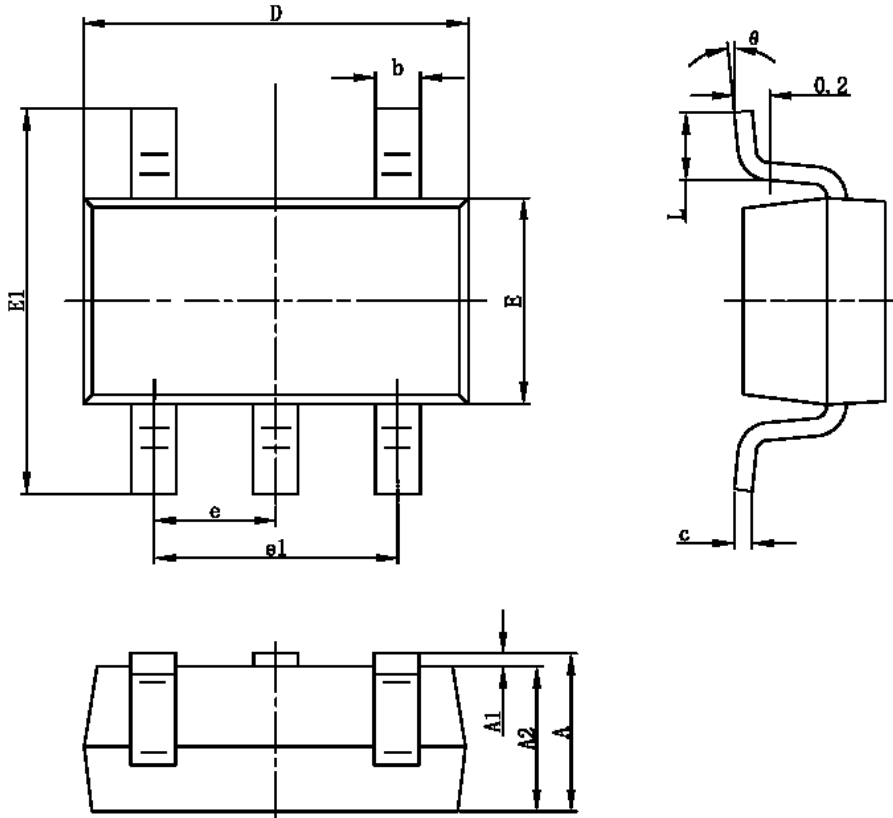
PACKAGE INFORMATION
SOT-23-5L PACKAGE OUTLINE DIMENSIONS

Symbol	Dimensions In Millimeters		Dimensions In Inches	
	Min	Max	Min	Max
A	1.050	1.250	0.041	0.049
A1	0.000	0.100	0.000	0.004
A2	1.050	1.150	0.041	0.045
b	0.300	0.500	0.012	0.020
c	0.100	0.200	0.004	0.008
D	2.820	3.020	0.111	0.119
E	1.500	1.700	0.059	0.067
E1	2.650	2.950	0.104	0.116
e	0.950(BSC)		0.037(BSC)	
e1	1.800	2.000	0.071	0.079
L	0.300	0.600	0.012	0.024
θ	0°	8°	0°	8°