

GENERAL DESCRIPTION

The PT5109 is a low-dropout voltage regulator designed for portable applications that require both low noise performance and board space. Its PSRR at 1kHz is better than 60dB. The PT5109's is ideal for battery powered systems for delivering low dropout voltage and low quiescent current.

The device can be used for mobile phones and similar battery powered wireless applications. It provides up to 300mA, from a 2.5V to 8V input. The PT5109 consumes less than 0.1 μ A in shutdown mode. The PT5109 is available in a 5 SOT-23 packages. Selected performances are specified for -40°C to $+85^{\circ}\text{C}$ temperature range. The output voltage is available in the range of 1.8V, 2.5V, 2.8V, 3.0V, 3.3V.

FEATURES

- 2.5V to 8V input range
- 60dB PSRR @1kHz, $V_{in} = V_{out} + 1V$
- $< 1\mu\text{A}$ quiescent current at shutdown mode
- 330mV maximum dropout voltage with 300mA load
- Thermal shutdown and short-circuit current limit
- 1.8V, 2.5V, 2.8V, 3.0V, 3.3V typical output standard
- 5 pin SOT23 packages

APPLICATIONS

- CDMA/GSM mobile phones
- Cordless telephones
- WLAN and bluetooth appliances
- PDAs/MP3
- Battery powered portable devices

ORDERING INFORMATION

Package	Temperature Range	(Output Voltage V)	Part Number	Transport Media
SOT23-5	$-40^{\circ}\text{C} \sim 85^{\circ}\text{C}$	1.8	PT5109E23E-18	Tape and reel 3000 units
		2.5	PT5109E23E-25	
		2.8	PT5109E23E-28	
		3.0	PT5109E23E-30	
		3.3	PT5109E23E-33	

TYPICAL APPLICATIONS

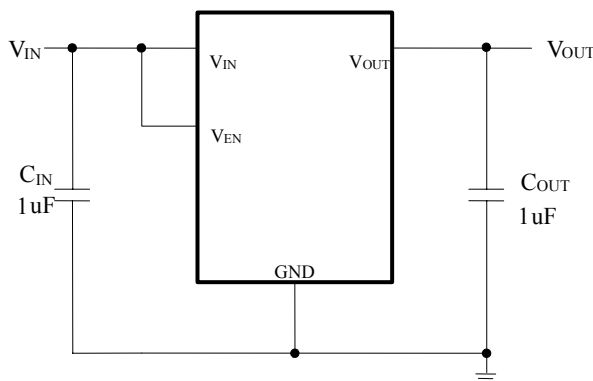

C_{OUT} : Recommended ceramic capacitor

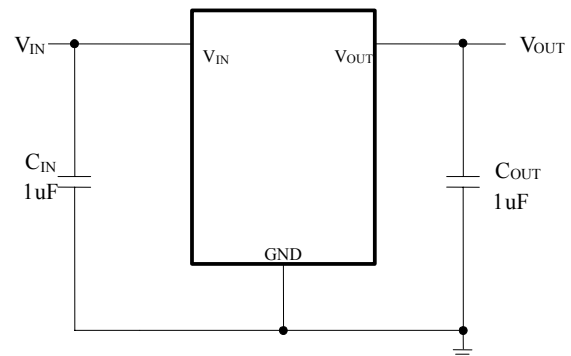

C_{OUT} : Recommended ceramic capacitor

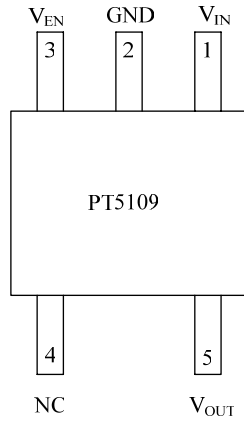
PIN ASSIGNMENT

SOT23-5

PIN DESCRIPTIONS

SYMBOL	SOT23-5	DESCRIPTION
V_{IN}	1	Input of LDO
GND	2	Ground
V_{OUT}	5	Output of LDO
V_{EN}	3	Enable Input Logic, Enable High
NC	4	No Connection

ABSOLUTE MAXIMUM RATINGS

PARAMETER	VALUE	UNIT
V_{IN} Range	-0.3~10.0V	V
V_{OUT} Range	-0.3~($V_{IN}+0.3$)< 10.0V	V
V_{EN} Range	-0.3~10.0V	V
Maximum Power Dissipation (Note1)	SOT23-5 0.365	W
Junction Temp.	150	°C
Storage Temp.	-65~150	°C
Lead Temp. (Note2)	235	°C
ESD Rating, HBM	2	KV

RECOMMENDED OPERATING RANGE

PARAMETER		VALUE	UNIT
V _{IN} Range		-0.3~8V	V
V _{EN} Range		-0.3~(V _{IN} +0.3)<8V	V
Thermal Resistance, θ_{JA}	SOT23-5	220	°C/W
Maximum Power Dissipation (Note 3)	SOT23-5	0.25	W
Operation Temp.		-40~85	°C

ELECTRICAL CHARACTERISTICS

Unless otherwise specified: V_{IN} = V_{OUT(nom)} + 1V, V_{EN} = V_{IN}, C_{IN} = 1 uF, I_{OUT} = 1mA, C_{OUT} = 1 uF, T_A = +25°C. Limits appearing in **boldface type** apply over the entire junction temperature range for operation, -40°C to +85°C. (Note 4) (Note5)

SYMBOL	PARAMETER	CONDITIONS	TYP.	MIN.	MAX.	UNIT
ΔV_{OUT}	Output Voltage Error	I _{OUT} = 1mA		-2	2	%/V _{OUT}
	Line Regulation Error	V _{IN} =(V _{OUT(nom)} + 0.5V) to 5.5V	0.02	-0.1	0.1	%/V
	Load Regulation Error (Note 6)	I _{OUT} = 1mA to 150 mA	15		50	mV
PSRR	Power Supply Rejection Ratio (Note 7)	V _{IN} = V _{OUT(nom)} + 1.0V f = 1kHz	I _{OUT} = 50mA	60		dB
		I _{OUT} = 150mA	60			
I _Q	Quiescent Current	I _{OUT} = 0 mA, V _{OUT} = 2.5V	35		50	uA
		V _{EN} = 0V	0.1		1.0	
V _{DIFF}	Dropout Voltage (Note 8)	I _{OUT} = 50 mA	40		50	mV
		I _{OUT} = 100 mA	70		220	
I _{SC}	Output Short Current Limit	Output Grounded	330			mA
I _{OUT(PK)}	Peak Output Current	V _{OUT} ≥ V _{OUT(nom)} - 5%	300			mA
I _{EN}	Maximum Input Current at V _{EN}	V _{EN} = 0 and V _{IN} = 5.5			500	nA
V _{IL}	Maximum Low Input Level at V _{EN}	V _{IN} = 2.5 to 5.5			0.4	V
V _{IH}	Minimum High Input Level at V _{EN}	V _{IN} = 2.5 to 5.5		1.4		V
TSD	Thermal Shutdown Temperature		160			°C
	Thermal Shutdown Hysteresis		20			°C
$\Delta V_{OUT}/V_{OUT}$	V _{OUT} Temperature Characteristics	Temperature = -40 to 125°C	100			ppm/°C

Note 1: The Absolute Maximum power dissipation depends on the ambient temperature and can be calculated using the formula: $P_D = (T_J - T_A) / \theta_{JA}$, where T_J is the junction temperature, T_A is the ambient temperature, and θ_{JA} is the junction-to-ambient thermal resistance. The 364mW rating for SOT23-5 appearing under Absolute Maximum Ratings results from substituting the Absolute Maximum junction temperature, 150°C, for T_J , 70°C for T_A , and 220°C/W for θ_{JA} . More power can be dissipated safely at ambient temperatures below 70°C. Less power can be dissipated safely at ambient temperatures above 70°C. The Absolute Maximum power dissipation can be increased by 4.5mW for each degree below 70°C, and it must be derated by 4.5mW for each degree above 70°C.

Note 2: Additional information on lead temperature and pad temperature may be obtained by contact CR PowTech

Note 3: Like the Absolute Maximum power dissipation, the maximum power dissipation for operation depends on the ambient temperature. The 250mW rating for SOT23-5 appearing under Operating Ratings results from substituting the maximum junction temperature for operation, 125°C, for T_J , 70°C for T_A , and 220°C/W for θ_{JA} above. More power can be dissipated at ambient temperatures below 70°C. Less power can be dissipated at ambient temperatures above 70°C. The maximum power dissipation for operation can be increased by 4.5mW for each degree below 70°C, and it must be derated by 4.5mW for each degree above 70°C.

Note 4: The target output voltage, which is labeled $V_{OUT(nom)}$, is the desired voltage option.

Note 5: All limits are guaranteed. All electrical characteristics having room-temperature limits are tested during production with $T_J = 25^\circ\text{C}$ or correlated using Statistical Quality Control (SQC) methods. All hot and cold limits are guaranteed by correlating the electrical characteristics to process and temperature variations and applying statistical process control.

Note 6: An increase in the load current results in a slight decrease in the output voltage and vice versa.

Note 7: The PSRR is measured by applying a 200mV_{P-P} sine wave on V_{IN} and measure the ripple at V_{OUT} (see Figure 2). Due to the very high PSRR performance of the PT5107, it is strongly recommended to use a spectrum analyzer rather than an oscilloscope to watch the PSRR performance.

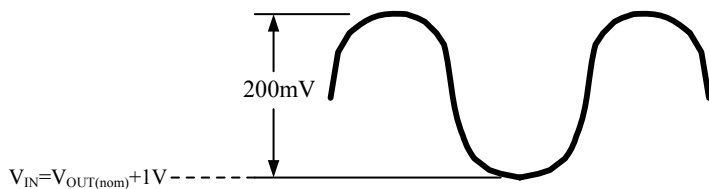

Figure 2.
Graph show the sine waveform added on V_{IN} to measure PSRR

Note 8: Dropout voltage is the input-to-output voltage difference at which the output voltage is 100mV below its nominal value. This specification does not apply for input voltages below 2.5V.

SIMPLIFIED BLOCK DIAGRAM

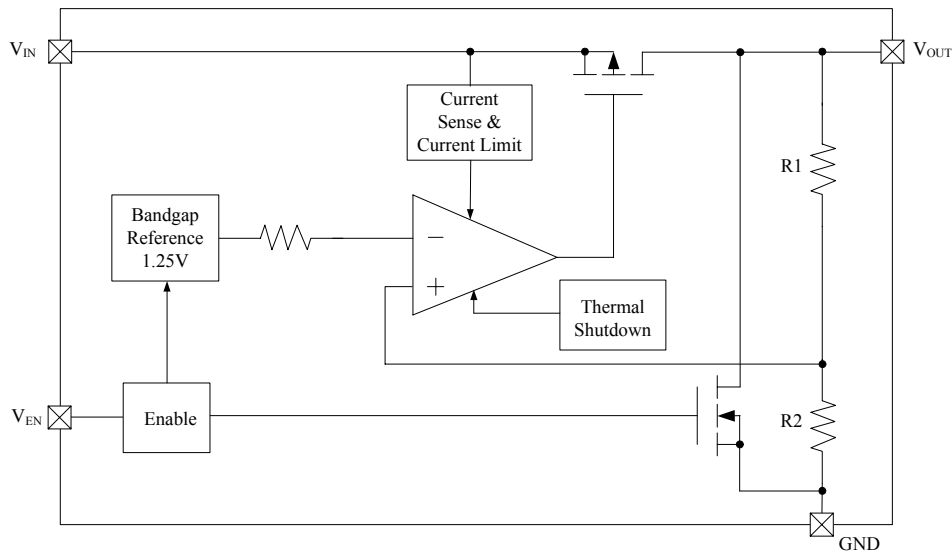
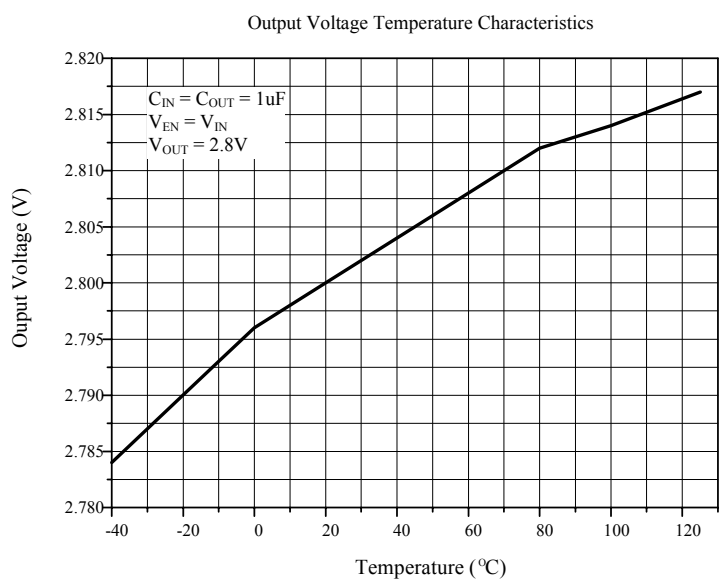
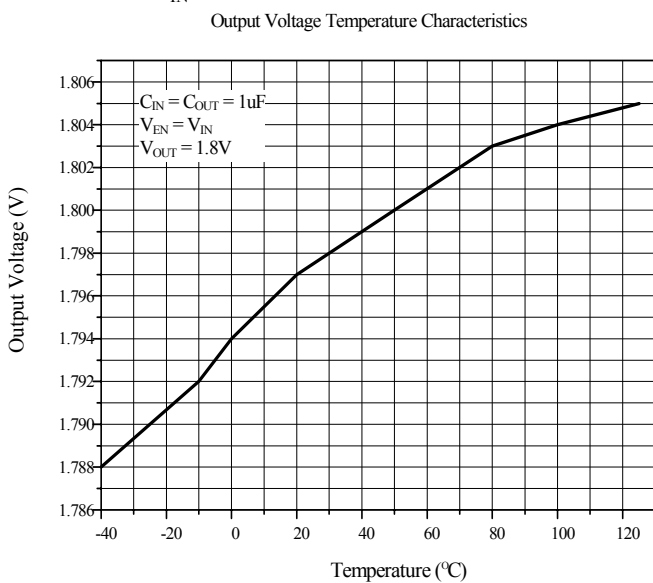

Figure1. Graph the PT5109 major functional blocks

In Figure 1, the block of Bandgap Reference provides the reference voltage of the LDO. The op amp block is used as the error amplifier of the LDO by compare the reference with the output feedback voltages. Its output controls the gate of a large PMOS driver and hereby adjusts the output voltage. The resistor R₁ and R₂ form a voltage divider to provide the feedback voltage. The Current Sense & Limit block senses the LDO output current and limits the output current from being too high. This is mostly a short circuit protection feature.

TYPICAL PERFORMANCE CHARACTERISTICS

Unless otherwise specified: V_{IN} = V_{OUT(nom)} + 1V, V_{EN} = V_{IN}, C_{IN} = C_{OUT} = 1 uF Ceramic, T_A = +25°C, Enable pin is tied to V_{IN}.



TYPICAL PERFORMANCE CHARACTERISTICS (Continued)

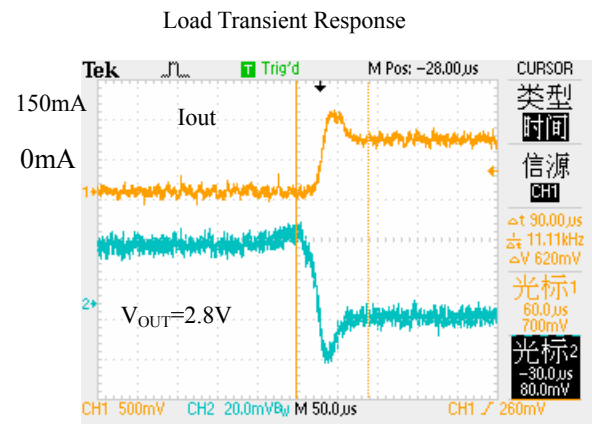
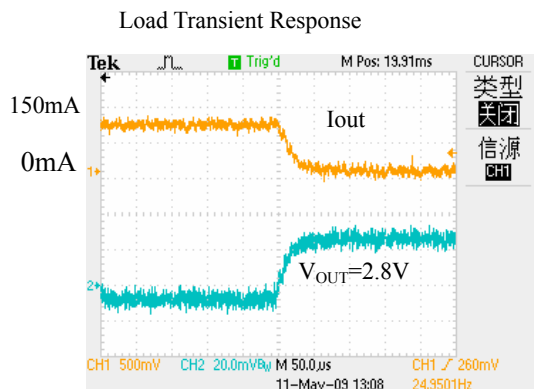
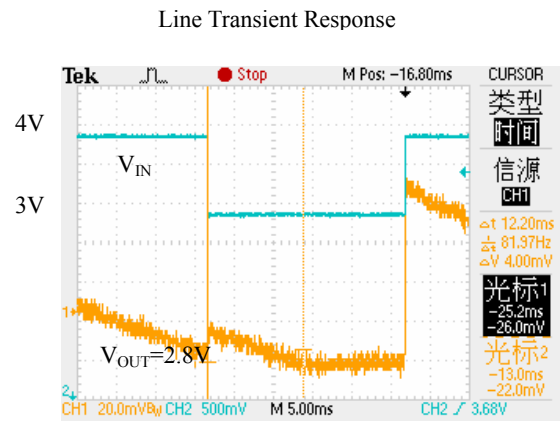
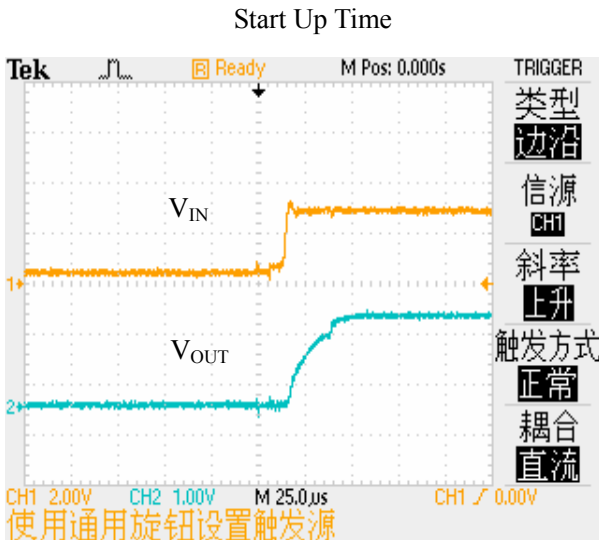
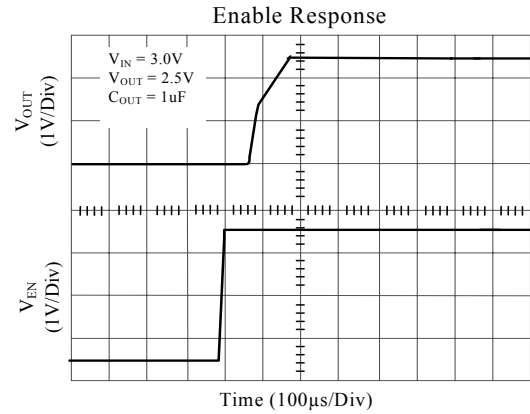
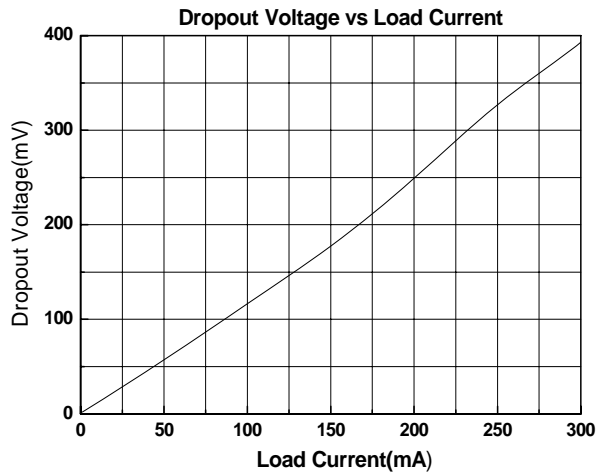

APPLICATION INFORMATION

INPUT CAPACITOR

An input capacitor of $\geq 1.0\mu\text{F}$ is required between the PT5109 V_{IN} and GND pin. This capacitor must be located within 1cm distance from V_{IN} pin and connected to a clear ground. A ceramic capacitor is recommended although a good quality tantalum or film may be used at the input. However, a tantalum capacitor can suffer catastrophic failures due to surge current when connected to a low impedance power supply (such as a battery or a very large capacitor).

There is no requirement for the ESR on the input capacitor, but tolerance and temperature coefficient must be considered in order to ensure the capacitor work within the operation range over the full range of temperature and operating conditions.

OUTPUT CAPACITOR

In applications, it is important to select the output capacitor to keep the PT5109 in stable operation. The output capacitor must meet all the requirements specified in the following recommended capacitor table over all conditions in applications. The minimum capacitance for stability and correct operation is $0.6\mu\text{F}$. The capacitance tolerance should be $\pm 30\%$ or better over the operation temperature range. The recommended capacitor type is X7R to meet the full device temperature specification.

Recommended Output Capacitor (C_{OUT})

	TYP	MIN	MAX	Unit
Capacitance	1.0	0.6	10	μF
ESR		0	400	$\text{m}\Omega$

The capacitor application conditions also include DC-bias, frequency and temperature. Unstable operation will result if the capacitance drops below minimum specified value (see the next section Capacitor Characteristics).

The PT5109 is designed to work with very small ceramic output capacitors. A $1.0\mu\text{F}$ capacitor (X7R type) with ESR type between 0 and $400\text{m}\Omega$ is suitable in the PT5109 applications. X5R capacitors may be used but have a narrow temperature range. With these and other capacitor types (Y5V, Z6U) that may be used, selection relies on the range of operating conditions and

temperature range for a specified application.

It may also be possible to use tantalum or film capacitors at the output, but these are not as good for reasons of size and cost.

It is also recommended that the output capacitor be located within 1cm from the output pin and return to a clean ground wire.

CAPACITOR CHARACTERISTICS

The PT5109 is designed to work with ceramic capacitor on the output to take advantage of the benefit they offer: for capacitor values from $1.0\mu\text{F}$ to $4.7\mu\text{F}$ range, ceramic capacitors are the smallest, least expensive and have the lowest ESR values (which is good for eliminating high frequency noise). The ESR of a typical $1\mu\text{F}$ ceramic capacitor is in the range of $20\text{m}\Omega$ to $40\text{m}\Omega$ that easily satisfies the ESR requirement for stability by the PT5109.

For both input and output capacitors careful understanding the capacitor specifications is required to ensure correct device operation. The capacitor value can change greatly because of the operating condition and capacitor type. In particular the output capacitor selection should take account of all the capacitor parameters to ensure that the specification is satisfied for the application. Capacitor values can vary with DC bias conditions, temperature, and frequency of operation. Capacitor values will also demonstrate some decrease over time due to aging. The capacitor parameters are also dependant on the particular case size with smaller size giving poorer performance figures on general.

As an example, the following figure shows a typical graph showing a comparison of capacitor case sizes in Capacitance vs. DC Bias plot. As shown in the graph, as a result of the DC bias condition the capacitance value may drop below the minimum capacitance value given in the recommended capacitor table. It is also recommended that the capacitor manufacture's specification for the normal value capacitor are consulted for all conditions as some capacitor sizes may not be suitable in the actual application.

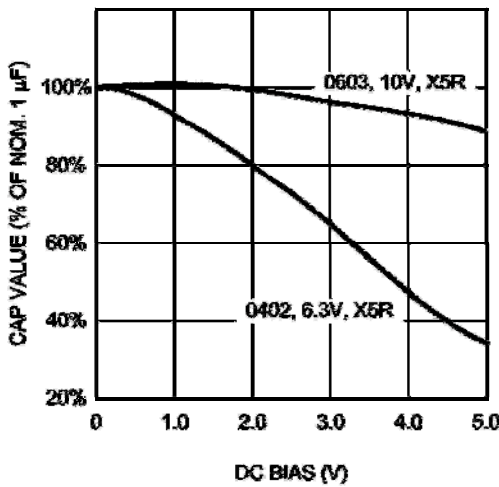

Figure 3. Graph showing a typical variation in capacitance vs. DC bias

The ceramic capacitor’s capacitance can vary with temperature. The capacitor type X7R, which operates over a temperature range of -55°C to +125°C, will only vary the capacitance to within ±15%. The capacitor type X5R has a similar tolerance over a reduced temperature range of -55°C to +85°C. Most large value ceramic capacitors (2.2μF) are manufactured with Z5U or Y5V temperature characteristics. Their capacitance can drop by more than 50% as the temperature goes from 25°C to 85°C. Therefore X7R is recommended over Z5U and Y5V in applications where the ambient temperature will change significantly above or below 25°C.

Tantalum capacitors are less desirable than ceramic for use as output capacitors because they are more expensive when comparing equivalent capacitance and voltage ratings in the 1μF to 4.7μF range.

Another important consideration is that tantalum capacitors have higher ESR values than equivalent size ceramics. This means that while it may be possible to find a tantalum capacitor with an ESR value within the stable range, it would have to be larger in capacitance (which means bigger and more costly) than a ceramic capacitor with the same ESR value. It should also be noted that the ESR of a typical tantalum will increase about 2:1 as the temperature goes from 25°C down to -40°C, so some guard band must be allowed.

NO-LOAD STABILITY

The PT5109 will remain stable and in regulation with no external load. This is especially important in CMOS RAM keep-alive applications.

ON/OFF INPUT OPERATION

The PT5109 is turned off by pulling the VEN pin low, and turned on by pulling it high. If this function is not used, the VEN pin should be tied to VIN to keep the regulator output on at all time. To assure proper operation, the signal source used to drive the VEN input must be able to swing above and below the specified turn-on/off voltage thresholds listed in the Electrical Characteristics section under VIL and VIH.

PACKAGE INFORMATION

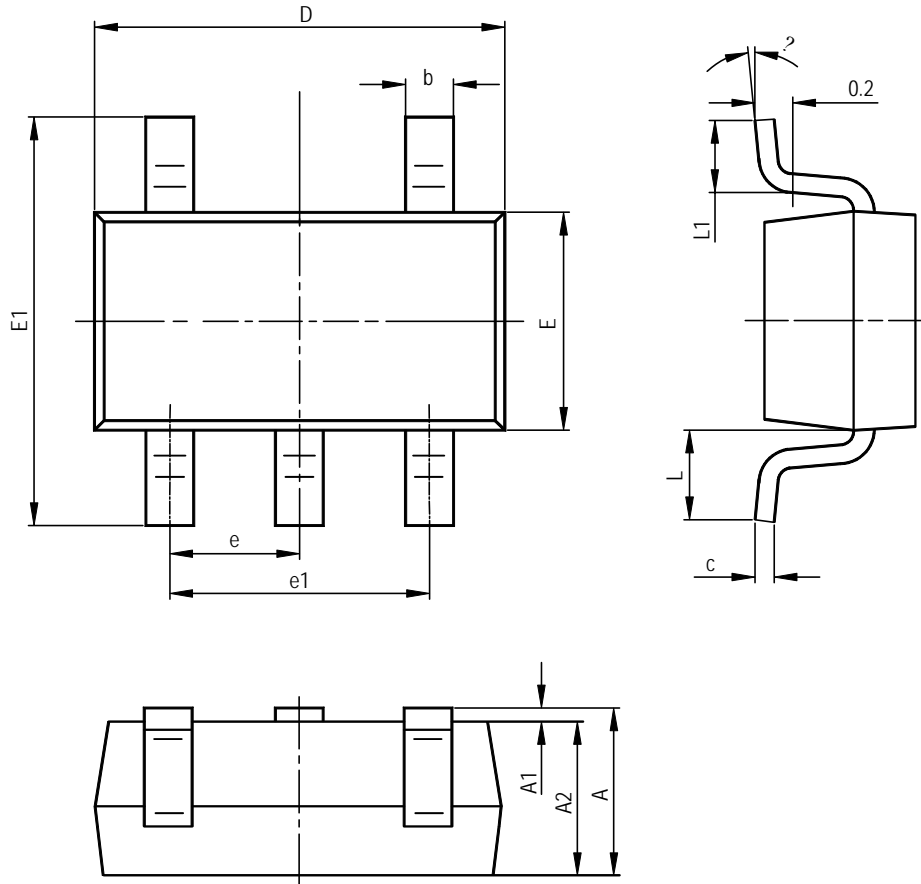
SOT23-5

SYMBOL	MILLIMETERS		INCHES	
	MIN	MAX	MIN	MAX
A	1.050	1.250	0.041	0.049
A1	0.000	0.100	0.000	0.004
A2	1.050	1.150	0.041	0.045
b	0.300	0.400	0.012	0.016
c	0.100	0.200	0.004	0.008
D	2.820	3.020	0.111	0.119
E	1.500	1.700	0.059	0.067
E1	2.650	2.950	0.104	0.116
e	0.950TYP		0.037TYP	
e1	1.800	2.000	0.071	0.079
L	0.700REF		0.028REF	
L1	0.300	0.600	0.012	0.024
θ	0°	8°	0°	8°