

2-Vrms Cap-Less Line Driver with Adjustable Gain

Features

- Operation Voltage: 3.0V to 3.6V
- Cap-less Output
 - Eliminates Output Capacitors
 - Improves Low Frequency Response
 - Reduces POP/Clicks
 - Reduce Board Area and Component Cost
- Low Noise and THD
 - SNR > 102dB
 - Typical $V_n < 12\mu\text{Vrms}$
 - THD+N < 0.02%
- Maximum Output Voltage Swing into 10k Ω Load
 - 2Vrms at 3.3V Supply Voltage
- 600 Ω Output Load Compliant
- Differential Input, single-Ended Output
- External Gain Setting from 1V/V to 10V/V
- Fast Start-up Time : 0.5ms
- Integrated De-Pop Control
- External Under Voltage Protection
- Thermal Protection
- Active Mute Control for Pop-less Audio ON/OFF Control
- +/-8kV IEC ESD Protection at line outputs

Applications

- LCD / PDP TVs
- CD / DVD players
- Set-Top Boxes
- Home Theater in Box

Description

The AD22653 is a 2-Vrms cap-less stereo line driver. The device is ideal for single supply electronics. Cap-less design can eliminate output dc-blocking capacitors for better low frequency response and save cost.

The AD22653 is capable of delivering 2-Vrms output into a 10k Ω load with 3.3V supply. The gain settings can be set by users from $\pm 1\text{V/V}$ to $\pm 10\text{V/V}$ externally, and gain can be configured individually for R/L channel. The AD22653 has built-in active-mute control for pop-less audio on/off control. The AD22653 has internal and external under voltage protection to prevent POP noise. Built-in de-pop control sequence also help AD22653 to be a pop-less device.

The AD22653 is available in a 14-pin TSSOP package.

Ordering Information

Product ID	Package	Packing	Comments
AD22653-QH14NAT	TSSOP-14	96 Units / Tube	Green
AD22653-QH14NAR		100 Tubes / Small Box	
		2.5k Units Tape & Reel	

Simplified Application Circuit

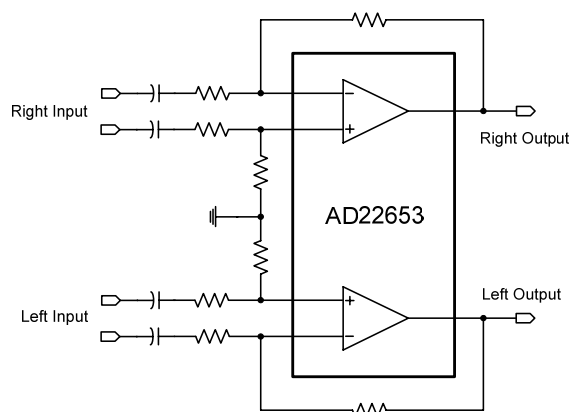

Pin Assignments

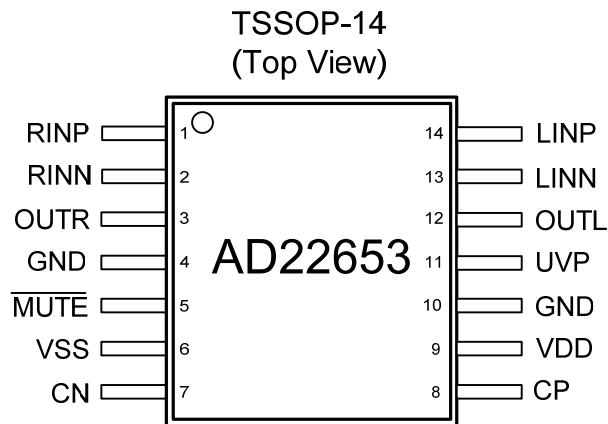

Pin Description

No.	Name	Type ⁽¹⁾	Pin Description
1	LINP	I	Left channel OP positive input
2	LINN	I	Left channel OP negative input
3	OUTL	O	Left channel OP output
4	SGND	P	Signal ground
5	$\overline{\text{MUTE}}$	I	Mute, active low
6	PVSS	O	Supply voltage
7	CN	I/O	Charge-pump flying capacitor negative terminal
8	CP	I/O	Charge-pump flying capacitor positive terminal
9	PVDD	P	Positive supply
10	PGND	P	Power ground
11	UVP	I	Under-voltage protection input
12	OUTR	O	Right channel OP output
13	RINN	I	Right channel OP negative input
14	RINP	I	Right channel OP positive input

(1) I=input, O=output, P=power