Stereo 2.4W Audio Power Amplifier with DC Volume Control and Selectable Gain

GENERAL DESCRIPTION

The EMA2202 is a monolithic integrated circuit that provides DC volume control, and stereo bridged audio power amplifiers capable of producing 2W into 4Ω or 2.4W into 3Ω with less than 1.0% THD+N.

The EMA2202 incorporates a DC volume control, stereo bridged audio power amplifiers and a selectable gain or bass boost, making it optimally suited for multimedia monitors, portable radios, desktop, and portable computer applications. The EMA2202 features an externally controlled, low-power consumption shutdown mode, and both power amplifier and headphone mute for maximum system flexibility and performance.

Advanced pop & click circuitry is built in to eliminate noises that would otherwise occur during turn-on and turn-off transitions.

KEY SPECIFICATION

- BTL mode P_o at 5V, f=1kHz, 1% THD+N
2.4W (typ) into 3Ω
2.0W (typ) into 4Ω

- 1.1W (typ) into 8Ω
- BTL mode P_o at 5V, f=1kHz, 10% THD+N
3W (typ) into 3Ω
- Single-ended mode P_o at 5V, f=1kHz, 1% THD+N
85mW (typ) into 32Ω
- Shutdown current 0.1μA (typ)

FEATURES

- 32 steps DC Volume Control
- System Beep Detect
- Stereo switchable bridged/single-ended power amplifiers
- Selectable internal/external gain and configurable bass boost
- "Click and pop" suppression circuitry
- Thermal shutdown protection circuitry

APPLICATIONS

- Portable and Desktop Computers
- Multimedia Monitors
- Portable Radios, PDAs, and Portable TVs

FUNCTION BLOCK DIAGRAM

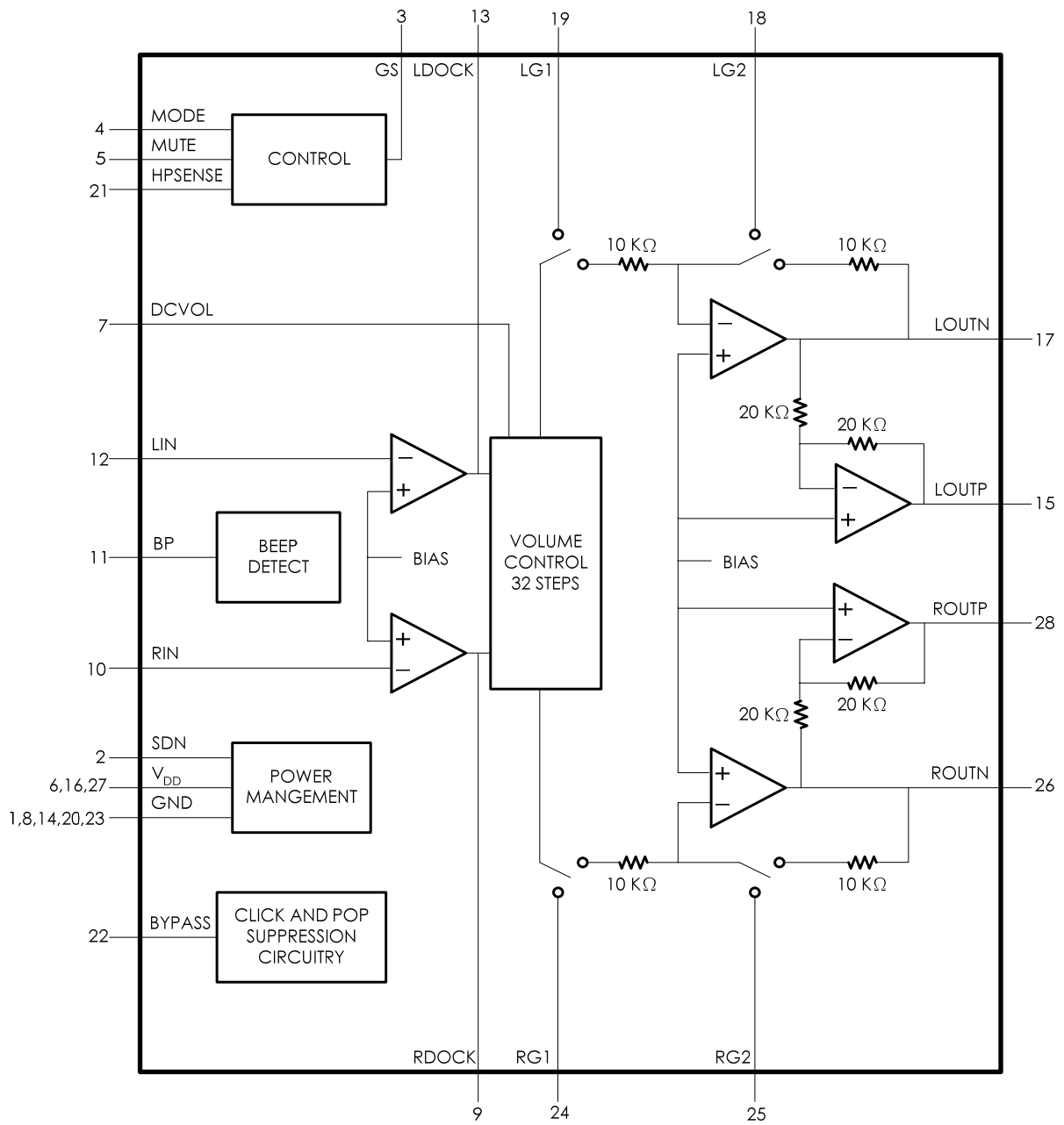

CONNECTION DIAGRAM

TSSOP-28FD Package

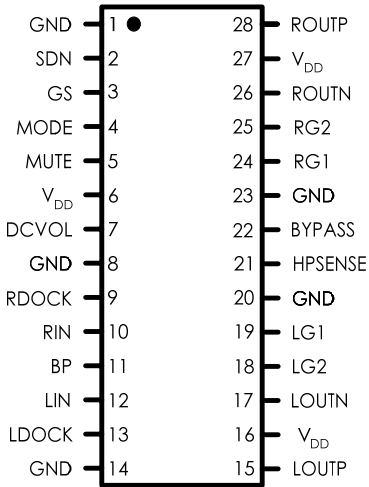

ORDER INFORMATION

EMA2202-50QE28GRR/NRR

50	5.0V Operation
QE28	TSSOP-28FD Package
GRR	RoHS (Pb Free)
	Rating: -40 to 85°C
	Package in Tape & Reel
NRR	RoHS & Halogen free (By Request)
	Rating: -40 to 85°C
	Package in Tape & Reel

Order, Mark & Packing Information

Package	Product ID	Marking	Packing
TSSOP-28FD	EMA2202-50QE28GRR	<p>EMP EMA2202 Tracking Code</p>	2.5K units Tape & Reel

TERMINAL FUNCTIONS

TERMINAL		I/O	Function DESCRIPTION
NAME	NO.		
GND	1,8,14,20,23	I	Ground
SDN	2	I	High Level Shutdown
GS	3	I	Internal / External Gain Selection
MODE	4	I	32-Steps Volume Control Enable/Disable
MUTE	5	I	Mute Function Enable/Disable
V _{DD}	6,16,27	I	Power Supply
DCVOL	7	I	DC Level Input for Volume Adjustment
RDOCK	9	O	Right Channel Audio Output as Pre-amplifier for Dock
LDOCK	13	O	Left Channel Audio Output as Pre-amplifier for Dock
RIN	10	I	Right Channel Audio Input
LIN	12	I	Left Channel Audio Input
BP	11	I	System Beep Signal Input
LOUTP	15	O	Left Channel Positive (Relative to LIN) Output
LOUTN	17	O	Left Channel Negative (Relative to LIN) Output
LG1	19	-	Left Channel External Gain Set 1
LG2	18	-	Left Channel External Gain Set 2
HPSENSE	21	I	Headphone Enable/Disable
BYPASS	22	-	Mid-supply voltage, Adding a Bypass Capacitor to Improve PSRR and Noise Immunity / Turn-on Time Define
RG1	24	-	Right Channel External Gain Set 1
RG2	25	-	Right Channel External Gain Set 2
ROUTN	26	O	Right Channel (Relative to RIN) Negative Output
ROUTP	28	O	Right Channel (Relative to RIN) Positive Output

TYPICAL APPLICATION CIRCUIT

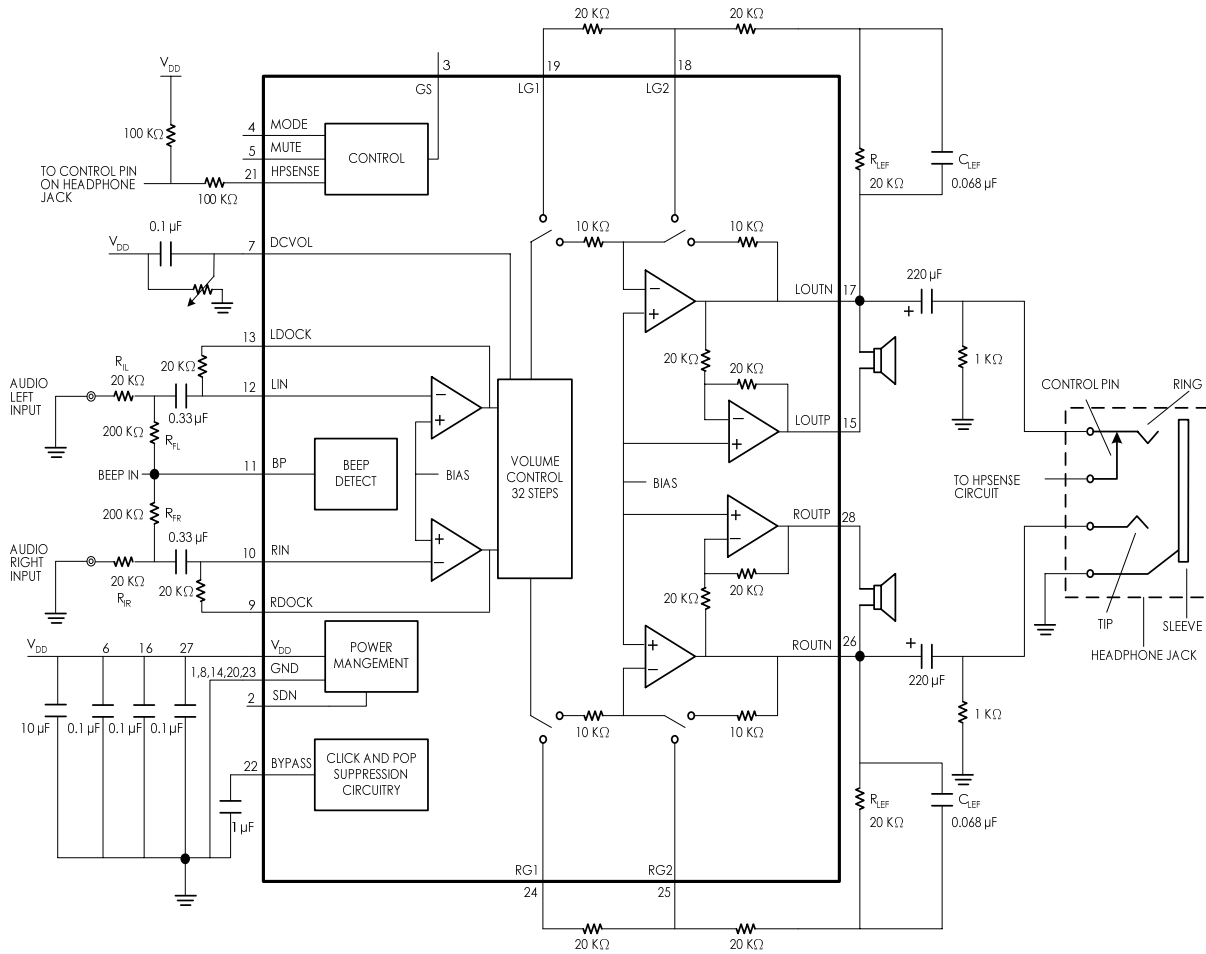

Figure 1. Typical Audio Power Amplifier Application Circuit

Absolute Maximum Ratings (Note 1)

Supply Voltage	6.0V	Thermal Resistance	
Storage Temperature	-65°C to +150°C	θ_{JA} (TSSOP-28FD)	80°C/W
Input Voltage	-0.3V to $V_{DD} + 0.3V$	Operating Ratings	
Power Dissipation	Internally Limited	Temperature Range	$-40^{\circ}\text{C} \leq T_A \leq 85^{\circ}\text{C}$
ESD Susceptibility	(Note 2) HBM 2kV (Note 3) MM 200V	Supply Voltage	$2.7\text{V} \leq V_{DD} \leq 5.5\text{V}$
Junction Temperature	150°C		

ELECTRICAL CHARACTERISTICS FOR ENTIRE IC

The following specifications apply for $V_{DD} = 5V$ unless otherwise specified. Limits apply for $T_A = 25^{\circ}\text{C}$.

Symbol	Parameter	Conditions	Conditions		Units (Limits)
			Typical	Limit	
V_{DD}	Supply Voltage			2.7	V (min)
				5.5	V (max)
I_{DD}	Quiescent Power Supply Current	Input AC to GND, No Load	10	20	mA (max)
I_{SD}	Shutdown Current	$V_{SDN} = 5V$	0.1	1.0	μA (max)
V_{IH}	HPSENSE High Level			4.0	V (min)
	SDN High Level			1.2	
V_{IL}	HPSENSE Low Level			0.8	V (max)
	SDN Low Level			0.4	

Electrical Characteristics for Volume Attenuators

The following specifications apply for $V_{DD} = 5V$, $A_V = 2$ unless otherwise specified. Limits apply for $T_A = 25^{\circ}\text{C}$.

Symbol	Parameter	Conditions	Conditions		Units (Limits)
			Typical	Limit	
C_{RANGE}	Attenuator Range	$V_{DCVOL} = 5V$	6		dB (max)
		$V_{DCVOL} = 0V$	-88	-80	dB (min)
AM	Mute Attenuation	$V_{MUTE} = 5V$, BTL Mode	-88	-80	dB (min)
		$V_{MUTE} = 5V$, SE Mode	-88	-80	dB (min)

Electrical Characteristics for Single-Ended Mode Operation

The following specifications apply for $V_{DD} = 5V$ unless otherwise specified. Limits apply for $T_A = 25^{\circ}\text{C}$.

Symbol	Parameter	Conditions	Conditions		Units (Limits)
			Typical	Limit	
P_O	Output Power	THD+N=1%, $f=1\text{kHz}$, 32Ω	85		mW
		THD+N=10%, $f=1\text{kHz}$, 32Ω	95		mW
THD+N	Total Harmonic Distortion + Noise	$V_{OUT} = 1 V_{RMS}$, $f=1\text{kHz}$, $10k\Omega$ $A_V = 1$	0.05		%

Electrical Characteristics for Single-Ended Mode Operation

The following specifications apply for $V_{DD} = 5V$ unless otherwise specified. Limits apply for $T_A = 25^{\circ}\text{C}$.

Symbol	Parameter	Conditions	Conditions		Units (Limits)
			Typical	Limit	
PSRR	Power Supply Rejection Ratio	$C_{BYPASS} = 1\mu\text{F}$, $f=120\text{Hz}$, $V_{RIPPLE} = 200\text{mV}_{RMS}$	58		dB
SNR	Signal to Noise Ratio	$P_{OUT} = 75\text{mW}$, 32Ω , A-Wtd filter	102		dB
X_{TALK}	Channel Separation	$C_{BYPASS} = 1\mu\text{F}$, $f=1\text{kHz}$,	65		dB

Electrical Characteristics for Bridged Mode Operation

The following specifications apply for $V_{DD} = 5V$ unless otherwise specified. Limits apply for $T_A = 25^\circ C$.

Symbol	Parameter	Conditions	Conditions		Units (Limits)
			Typical	Limit	
V_{OS}	Output Offset Voltage		5	50	mV (max)
P_O	Output Power	THD+N = 1% ; f=1kHz, 3 Ω	2.4		W
		THD+N = 1% ; f=1kHz, 4 Ω	2		W
		THD+N = 1% ; f=1kHz, 8 Ω	1.1	1.0	W(min)
		THD+N = 10% ; f=1kHz, 8 Ω	1.5		W
T_{WU}	Wake-up time	$C_{Bypass} = 1\mu F$	300	600	ms (max)
T_{SD}	Thermal Shutdown Temperature		160		$^\circ C$
THD+N	Total Harmonic Distortion + Noise	$P_O = 1 W$; 20Hz<f<20kHz, 8 Ω , $A_v=2$	0.3		%
		$P_O = 340mW$, 32 Ω	1.0		%
PSRR	Power Supply Rejection Ratio	$C_{Bypass}=1\mu F$, f=120Hz, 4 Ω $V_{RIPPLE}=200m V_{RMS}$	60		dB (min)
SNR	Signal to Noise Ratio	$P_O=1.1W$, 8 Ω , A-Wtd filter	93		dB
X_{TALK}	Channel Separation	$C_{Bypass}=1\mu F$, f=1kHz,	80		dB
T_{SD}	Shut Down Time		0.1		ms (max)

Note 1: *Absolute Maximum Ratings* indicate limits beyond which damage to the device may occur. *Operating Ratings* indicate conditions for which the device is functional, but do not guarantee specific performance limits. *Electrical Characteristics* state DC and AC electrical specifications under particular test conditions which guarantee specific performance limits. This assumes that the device is within the Operating Ratings. Specifications are not guaranteed for parameters where no limit is given, however, the typical value is a good indication of device performance.

Note 2: Human body model, 100pF discharged through a 1.5k Ω resistor.

Note 3: Machine Model, 220pF–240pF discharged through all pins.

Note 4: All voltages are measured with respect to the ground pins, unless otherwise specified. All specifications are tested using the typical application as shown in *Figure 1*.

TYPICAL PERFORMANCE CHARACTERISTICS

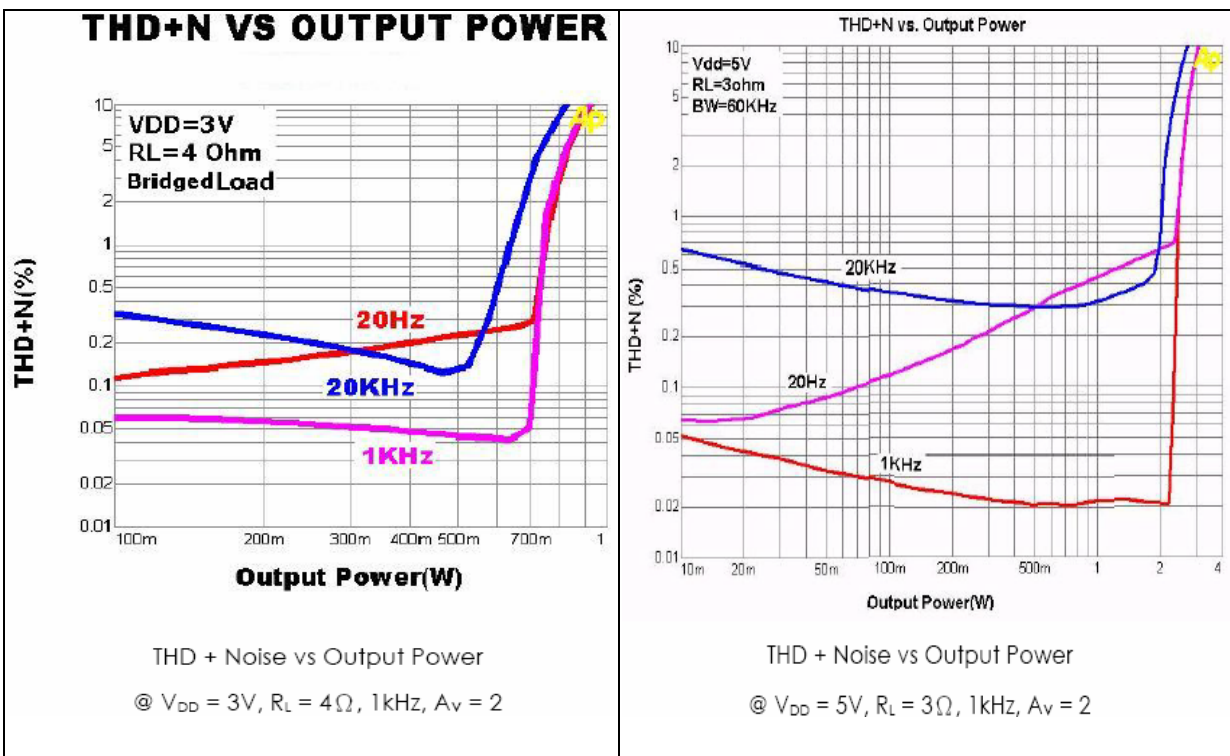
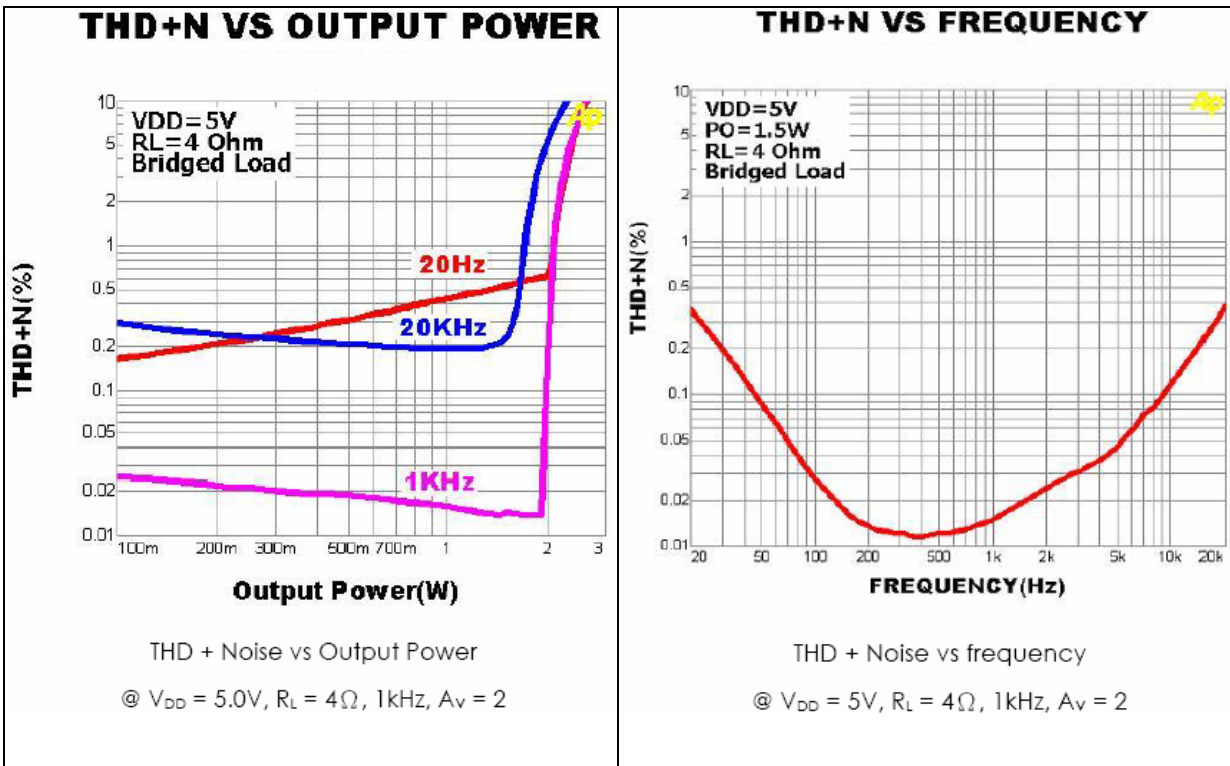

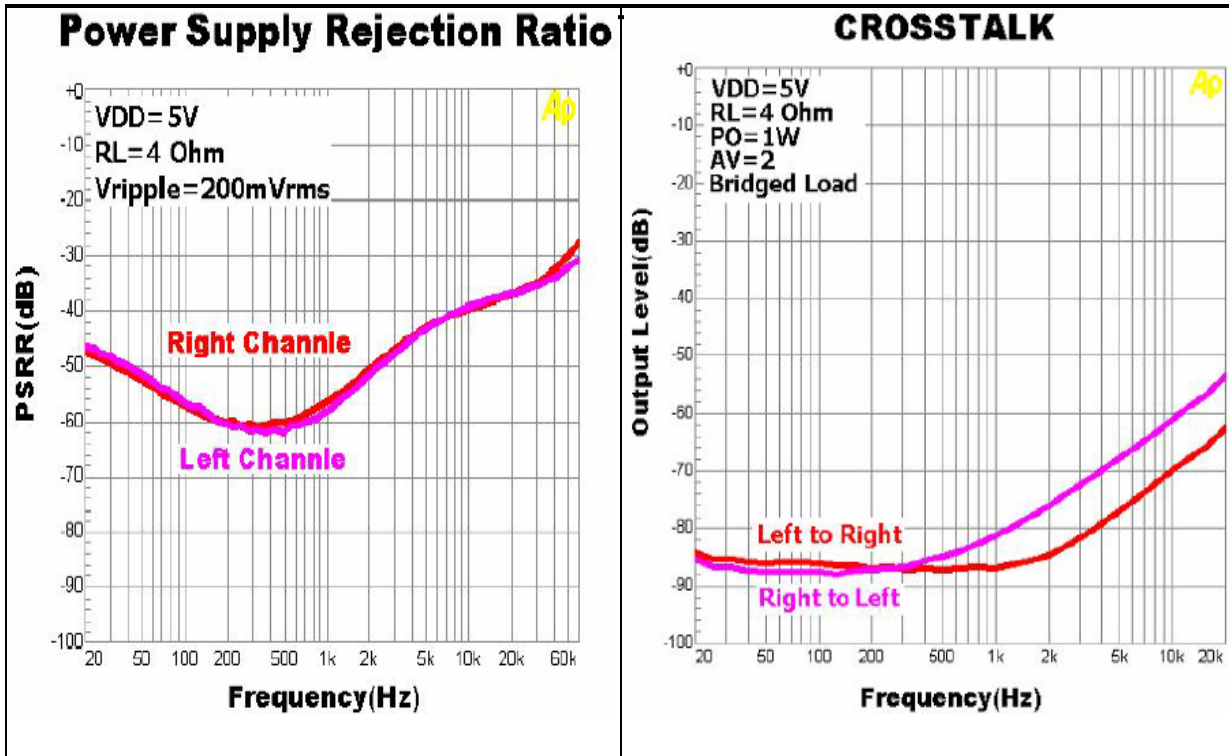

TRUTH TABLE FOR LOGIC INPUTS (Note 5)

MUTE	MODE	HPSENSE	DC Vol. Control	Bridged Output	Single-Ended Output
0	0	0	Fixed Level	Vol. Fixed	-
0	0	1	Fixed Level	-	Vol. Fixed
0	1	0	Adjustable	Vol. Changes	-
0	1	1	Adjustable	-	Vol. Changes
1	X	X	-	Muted	Muted

Note 5: If system beep is detected on the Beep In pin (pin 11), the system beep will be passed through the bridged amplifier regardless of the logic of the Mute and HPSENSE pins.

POWER SUPPLY BYPASSING

As with any power amplifier, proper supply bypassing is critical for low noise performance and high power supply rejection. Applications that employ a 5V regulator typically use a 10 μ F in parallel with a 0.1 μ F filter capacitors to stabilize the regulator's output, reduce noise on the supply line, and improve the supply's transient response. However, their presence does not eliminate the need for a local 1.0 μ F tantalum bypass capacitance connected between the EMA2202's supply pins and ground. Do not substitute a ceramic capacitor for the tantalum. Doing so may cause oscillation. Keep the length of leads and traces that connect capacitors between the EMA2202's power supply pin and ground as short as possible. Connecting a 1 μ F capacitor, C_{BYPASS}, between the BYPASS pin and ground improves the internal bias voltage's stability and improves the amplifier's PSRR. The PSRR improvements increase as the bypass pin capacitor value increases. Too large, however, increases turn-on time and can compromise amplifier's click and pop performance. The selection of bypass capacitor values, especially C_{BYPASS}, depends on desired PSRR requirements, click and pop performance, system cost, and size constraints.

SELECTING PROPER EXTERNAL COMPONENTS

Optimizing the EMA2202's performance requires properly selecting external components. Though the EMA2202 operates well when using external components with wide tolerances, best performance is achieved by optimizing component values. The EMA2202 is unity-gain stable, giving a designer maximum design flexibility. The gain should be set to no more than a given application requires. This allows the amplifier to achieve minimum THD+N and maximum signal-to-noise ratio. These parameters are compromised as the closed-loop gain increases. However, low gain demands input signals with greater voltage swings to achieve maximum output power. Fortunately, many signal sources such as audio CODECs have outputs of 1V_{RMS} (2.83V_{P-P}).

INPUT CAPACITOR VALUE SELECTION

Amplifying the lowest audio frequencies requires high value input coupling capacitor (0.33 μ F in *Figure 1*). A high value capacitor can be expensive and may compromise space efficiency in portable designs. In many cases, however, the speakers used in portable systems, whether internal or external, have little ability to reproduce signals below 150 Hz. Applications using speakers with this limited frequency response reap little improvement by using large input capacitor.

Besides effecting system cost and size, the input coupling capacitor has an affect on the EMA2202's click and pop performance. When the supply voltage is first applied, a transient (pop) is created as the charge on the input capacitor changes from zero to a quiescent state. The magnitude of the pop is directly proportional to the input capacitor's size. Higher value capacitors need more time to reach a quiescent DC voltage (usually V_{DD}/2) when charged with a fixed current. The amplifier's output charges the input capacitor through the feedback resistor, R_f. Thus, pops can be minimized by selecting an input capacitor value that is no higher than necessary to meet the desired -3dB frequency.

As shown in *Figure 1*, the input resistor (20k Ω) and the input capacitor produce a -3dB high pass filter cutoff frequency that is found using Equation (1).

$$f_{-3dB} = \frac{1}{2\pi R_{IN} C_1} \quad (1)$$

As an example when using a speaker with a low frequency limit of 150Hz, the input coupling capacitor, using Equation (1), is 0.063 μ F. The 0.33 μ F input coupling capacitor shown in *Figure 1* allows the EMA2202 to drive high efficiency, full range speaker whose response extends below 30Hz.

OPTIMIZING CLICK AND POP REDUCTION PERFORMANCE

The EMA2202 contains circuitry that minimizes turn-on and shutdown transients or "clicks and pop". For this discussion, turn-on refers to either applying the power supply voltage or when the shutdown mode is deactivated. While the power supply is ramping to its final value, the EMA2202's internal amplifiers are configured as unity gain buffers. An internal current source changes the voltage of the BYPASS pin in a controlled, linear manner. Ideally, the input and outputs track the voltage applied to the BYPASS pin. The gain of the internal amplifiers remains unity until the voltage on the bypass pin reaches 1/2 V_{DD}. As soon as the voltage on the bypass pin is stable, the device becomes fully operational. Although the BYPASS pin current cannot be modified, changing the size of C_{Bypass} alters the device's turn-on time and the magnitude of "clicks and pops". Increasing the value of C_{Bypass} reduces the magnitude of turn-on pops. However, this presents a tradeoff: as the size of C_{Bypass} increases, the turn-on time increases. There is a linear relationship between the size of C_{Bypass} and the turn-on time. Here are some typical turn-on times for various values of C_{Bypass}:

C _B	T _{ON}
0.1 μF	30 ms
0.22 μF	60 ms
0.47 μF	150 ms
1.0 μF	300 ms

In order to eliminate "clicks and pops", all capacitors must be discharged before turn-on. Rapidly switching V_{DD} may not allow the capacitors to fully discharge, which may cause "clicks and pops". In a single-ended configuration, the output is coupled to the load by C_{OUT}. This capacitor usually has a high value. C_{OUT} discharges through internal switch. Depending on the size of C_{OUT}, the discharge time constant can be relatively large. To reduce transients in single-ended mode, an external 1kΩ–5kΩ resistor R_{PULL} can be placed in parallel with the load resistor. For EMA2202 operating in single-ended mode, turn-on time is typical 800ms with 1.0 μF BYPASS capacitor to reach good "clicks and pops" elimination performance.

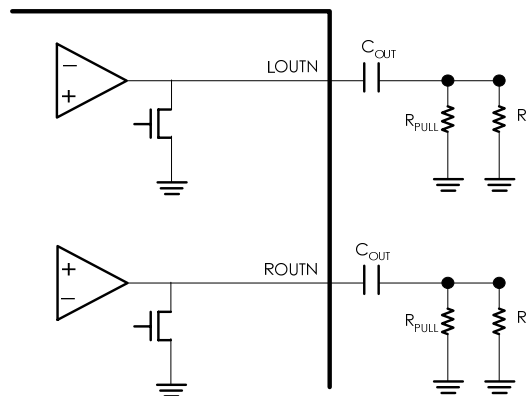

Figure2. Single-ended Output Configuration

DOCKING STATION INTERFACE

Applications such as notebook computers can take advantage of a docking station to connect to external devices such as monitors or audio/visual equipment that sends or receives line level signals. The EMA2202 has two outputs, Pin 9 and Pin 13, which connect to outputs of the internal input amplifiers that drive the volume control inputs. These input amplifiers can drive loads of >1kΩ (such as powered speakers) with a rail-to-rail signal. Since the output signal present on the RDOCK and LDOCK pins is biased to V_{DD}/2, coupling capacitors should be connected in series with the load. Typical values for the coupling capacitors are 0.33μF to 1.0μF. If polarized coupling capacitors are used, connect their "+" terminals to the respective output pin.

Since the DOCK outputs precede the internal volume control, the signal amplitude will be equal to the input signal's magnitude and cannot be adjusted. However, the input amplifier's closed-loop gain can be adjusted using external resistors. These resistors are shown in Figure 1 as 20kΩ devices that set each input amplifier's gain to -1. Use Equation 2 to determine the input and feedback resistor values for a desired gain.

$$-A_v = \frac{R_f}{R_i} \tag{2}$$

Adjusting the input amplifier's gain sets the minimum gain for that channel. The DOCK outputs adds circuit and functional flexibility because their use supercedes using the inverting outputs of each bridged output amplifier as line-level outputs.

BEEP DETECT FUNCTION

Computers and notebooks produce a system "beep" signal that drives a small speaker. The speaker's auditory output signifies that the system requires user attention or input. To accommodate this system alert signal, the EMA2202's pin 11 is a mono input that accepts the beep signal. Internal level detection circuitry at this input monitors the beep signal's magnitude. When a signal level greater than $V_{DD}/2$ is detected on pin 11, the bridge output amplifiers are enabled. The beep signal is amplified and applied to the load connected to the output amplifiers. A valid beep signal will be applied to the load even when MUTE is active. Use the input resistors connected between the BP pin and the stereo input pins to accommodate different beep signal amplitudes. These resistors are shown as 200k devices in *Figure 1*. Use higher value resistors to reduce the gain applied to the beep signal. The resistors must be used to pass the beep signal to the stereo inputs. The BP pin is used only to detect the beep signal's magnitude: it does not pass the signal to the output amplifiers. The EMA2202's shutdown mode must be deactivated before a system alert signal is applied to BP pin.

MICRO-POWER SHUTDOWN

The voltage applied to the SDN pin controls the EMA2202's shutdown function. Activate micro-power shutdown by applying V_{DD} to the SDN pin. When active, the EMA2202's micro-power shutdown feature turns off the amplifier's bias circuitry, reducing the supply current. The logic threshold is typically $V_{DD}/2$. The low 0.1 μ A typical shutdown current is achieved by applying a voltage that is as near as V_{DD} as possible to the SDN pin. A voltage that is less than V_{DD} may increase the shutdown current. *Table 1* shows the logic signal levels that activate and deactivate micro-power shutdown and headphone amplifier operation.

There are a few ways to control the micro-power shutdown. These include using a single-pole, single-throw switch, a microprocessor, or a microcontroller. When using a switch, connecting an external 10k Ω pull-up resistor between the SDN pin and V_{DD} . Connect the switch between the SDN pin and ground. Select normal amplifier operation by closing the switch. Opening the switch connects the SDN pin to V_{DD} through the pull-up resistor, activating micro-power shutdown. The switch and resistor guarantee that the SDN pin will not float. This prevents unwanted state changes. In a system with a microprocessor or a microcontroller, use a digital output to apply the control voltage to the SDN pin. Driving the SDN pin with active circuitry eliminates the pull up resistor.

TABLE 1. Truth Table for SDN and HPSENSE Operation

SDN PIN	HPSENSE PIN	OPERATIONAL MODE (MUX INPUT CHANNEL #)
Logic Low	Logic Low	Bridged Amplifiers
Logic Low	Logic High	Single-Ended Amplifiers
Logic High	-	Micro-Power Shutdown

MODE FUNCTION

The EMA2202's MODE function has two states controlled by the voltage applied to the MODE pin (pin 4). Mode 0, selected by applying 0V to the MODE pin, forces the EMA2202 to effectively function as a "line-out," unity-gain amplifier. Mode 1, which uses the internal DC controlled volume control, is selected by applying V_{DD} to the MODE pin. This mode sets the amplifier's gain according to the DC voltage applied to the DCVOL pin. Prevent unanticipated gain behavior by connecting the MODE pin to V_{DD} or ground. Do not let pin 4 float.

MUTE FUNCTION

The EMA2202 mutes the amplifier and DOCK outputs when V_{DD} is applied to pin 5, the MUTE pin. Even while muted, the EMA2202 will amplify a system alert (beep) signal whose magnitude satisfies the BEEP DETECT circuitry. Applying 0V to the MUTE pin returns the EMA2202 to normal, unmuted operation. Prevent unanticipated mute behavior by connecting the MUTE pin to V_{DD} or ground. Do not let pin 5 float.

HPSENSE FUNCTION

Applying a voltage between 4V and V_{DD} to the EMA2202's HPSENSE headphone control pin turns off inverting amplifier of each channel, muting a bridged-connected load. Quiescent current consumption is reduced when the IC is in this single-ended mode.

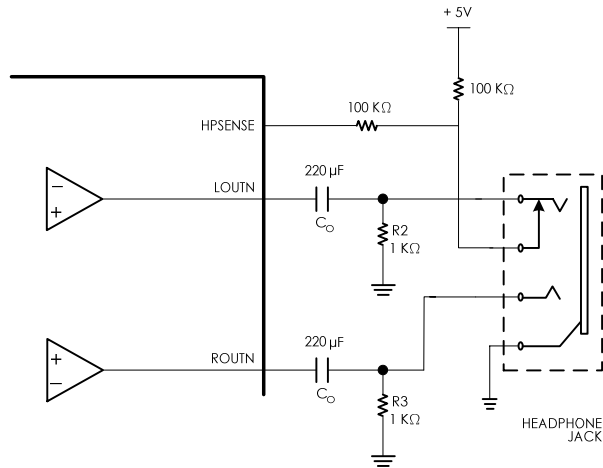

Figure3. Headphone Sensing Circuit

GAIN SELECT FUNCTION (Bass Boost)

The EMA2202 features selectable gain, using either internal or external feedback resistors. Either set of feedback resistors set the gain of the output amplifiers. The voltage applied to pin 3 (GS pin) controls which gain is selected. Applying VDD to the GS pin selects the external gain mode. Applying 0V to the GS pin selects the internally set unity gain.

In some cases a designer may want to improve the low frequency response of the bridged amplifier or incorporate a bass boost feature. This bass boost can be useful in systems where speakers are housed in small enclosures. A resistor, R_{LFE} , and a capacitor, C_{LFE} , in parallel, can be placed in series with the feedback resistor of the bridged amplifier as seen in *Figure 1*.

At low frequencies, C_{LFE} is a virtual open circuit and at high frequencies, its nearly zero ohm impedance shorts R_{LFE} . The result is increased bridge-amplifier gain at low frequencies. The combination of R_{LFE} and C_{LFE} form with a -3dB corner frequency at

$$f_c = \frac{1}{2\pi R_{LFE} C_{LFE}} \quad (3)$$

The bridged-amplifier low frequency differential gain is:

$$A_{VD} = \frac{2(R_F + R_{LFE})}{R_I} \quad (4)$$

Using the component values shown in *Figure 1* ($R_F = 20k\Omega$, $R_{LFE} = 20k\Omega$, and $C_{LFE} = 0.068\mu F$), a first-order, -3dB pole is created at 120Hz. Assuming $R_I = 20k\Omega$, the low frequency differential gain is 4. The input (C_I) and output (C_{OUT}) capacitor values must be selected for a low frequency response that covers the range of frequencies affected by the desired bass-boost operation.

DC VOLUME CONTROL

The EMA2202 has an internal stereo volume control whose setting is a function of the DC voltage applied to the DCVOL pin. The volume control's voltage input range is 0V to V_{DD} . The volume range is from 6dB (DC control voltage = 80% V_{DD}) to -88dB (DC control voltage = 0V). The volume remains at 6dB for DC control voltages greater than 80% V_{DD} . When the MODE input is 0V, the EMA2202 operates at unity gain, bypassing the volume control. A graph showing a typical volume response versus DC control voltage is shown below.

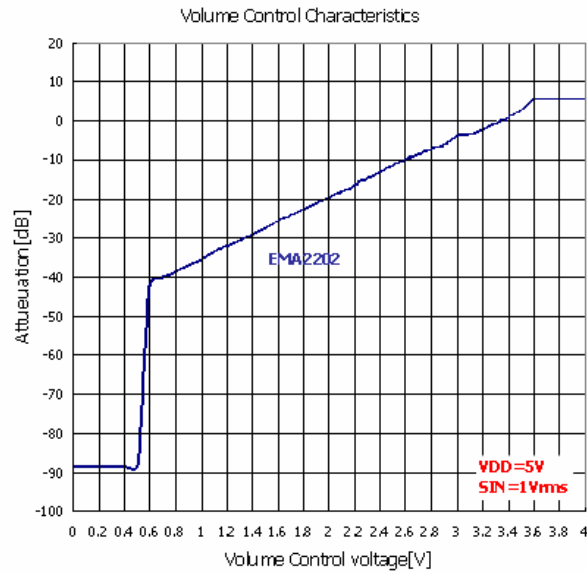

Like all volume controls, the EMA2202's internal volume control is set while listening to an amplified signal that is applied to an external speaker. The actual voltage applied to the DCVOL pin is a result of the volume a listener desires. As such, the volume control is designed for use in a feedback system that includes human ears and preferences. This feedback system operates quite well without the need for accurate gain. The user simply sets the volume to the desired level as determined by their ear, without regard to the actual DC voltage that produces the volume. Therefore, the accuracy of the volume control is not critical, as long as the volume changes monotonically, matches well between stereo channels, and the step size is small enough to reach a desired volume that is not too loud or too soft. Since gain accuracy is not critical, there will be volume variation from part-to-part even with the same applied DC control voltage. The gain of a given EMA2202 can be set with a fixed external voltage, but another EMA2202 may require a different control voltage to achieve the same gain. The typical part-to-part variation can be as large as 8dB for the same control voltage.

Physical Dimensions (TSSOP-28FD Package)

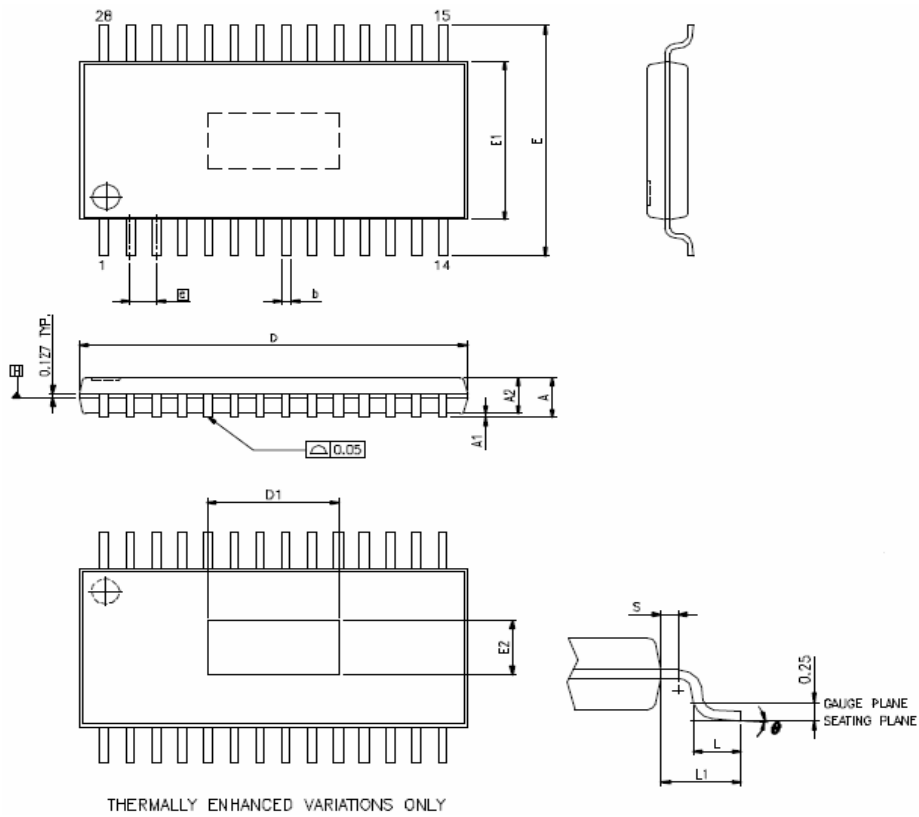

SYMBOLS	MIN	NOM	MAX
A	-	-	1.20
A1	0.00	-	0.15
a2	0.80	1.00	1.05
b	0.19	-	0.30
D	9.60	9.70	9.80
E1	4.30	4.40	4.50
E	6.40 BSC		
e	0.65 BSC		
L1	1.00 BSC		
L	0.45	0.60	0.75
S	0.20	-	-
θ	0°	-	8°

Unit : mm

PAD SIZE	E2	D1
118X21E	2.70 REF	4.98 REF

Revision History

Revision	Date	Description
4.0	2009.06.05	EMP transferred from version 3.1

Important Notice

All rights reserved.

No part of this document may be reproduced or duplicated in any form or by any means without the prior permission of ESMT.

The contents contained in this document are believed to be accurate at the time of publication. ESMT assumes no responsibility for any error in this document, and reserves the right to change the products or specification in this document without notice.

The information contained herein is presented only as a guide or examples for the application of our products. No responsibility is assumed by ESMT for any infringement of patents, copyrights, or other intellectual property rights of third parties which may result from its use. No license, either express, implied or otherwise, is granted under any patents, copyrights or other intellectual property rights of ESMT or others.

Any semiconductor devices may have inherently a certain rate of failure. To minimize risks associated with customer's application, adequate design and operating safeguards against injury, damage, or loss from such failure, should be provided by the customer when making application designs.

ESMT's products are not authorized for use in critical applications such as, but not limited to, life support devices or system, where failure or abnormal operation may directly affect human lives or cause physical injury or property damage. If products described here are to be used for such kinds of application, purchaser must do its own quality assurance testing appropriate to such applications.