

3A, Synchronous Step-Down DC-DC Converter

General Description

EML3172 is a high efficiency, DC-DC synchronous buck converter which provides 3A output loading after output voltage reach preset voltage. EML3172 uses different modulation algorithms for various loading conditions. Under heavy load, EML3172 regulates the output voltage using Pulse Width Modulation (PWM). The PWM mode provides low output voltage ripple and fixed frequency noise. While in light load, it enters Power Save Modulation (PSM) automatically to ensure a highly efficient operation at light load condition. Under very heavy load condition or when the input voltage approaches the output voltage, EML3172 enters low dropout voltage operation under 100% duty cycle.

The internal generated 0.8V precision feedback reference voltage is designed for low output voltage request. Low Power-FET Ron synchronous switch dramatically reduces conduction loss.

The EML3172 is available in the tiny package of TSOT-23-6.

Typical Application

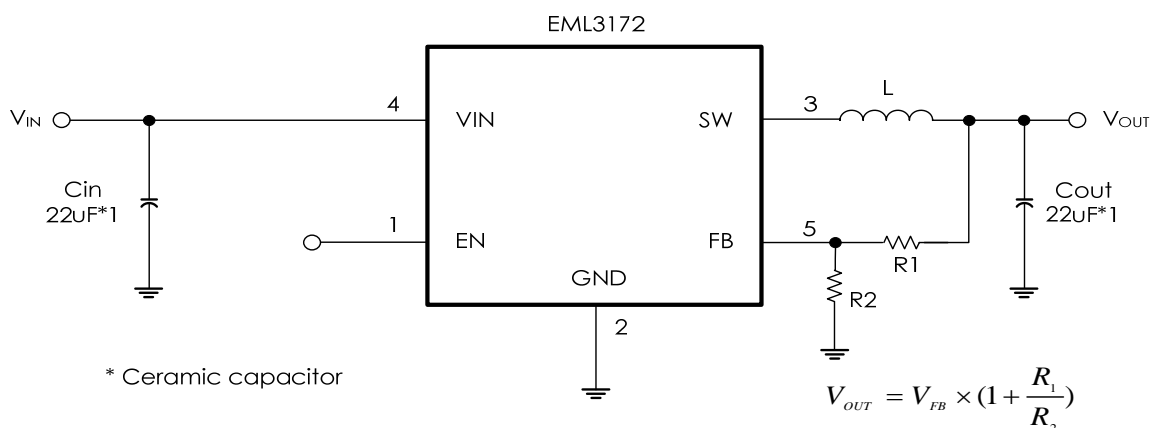

Fig. 1 EML3172 application circuit

Features

- Wide Operating Voltage Ranges : 2.5V to 5.5V
- 3A Output Current
- High efficiency Buck Power Converter
- Auto-select PSM/PWM
- LDO mode: duty cycle: 100%
- Synchronous Power Switches Rectification, no Schottky Diode Required
- 1.4MHz Switching Frequency
- Internal Soft-Start
- Current Limit Protection
- Over Temperature Protection
- Output Shorting Protect
- Output Over Voltage Protection

Applications

- Cellular telephone
- Wireless and DSL Modems
- Digital Still Cameras
- Portable Products
- MP3 Players

Package Configuration

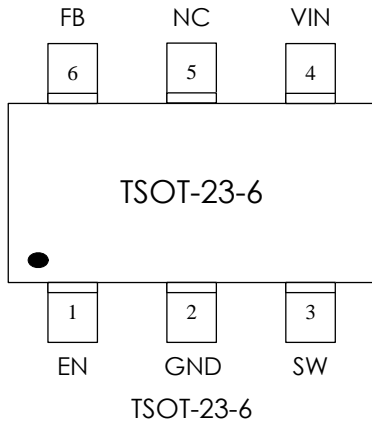

EML3172-XXVT06NRR

- XX Output Voltage
- 00 Adjustable Output
- VT06 TSOT-23-6 Package
- NRR RoHS & Halogen free package
Commercial Grade Temperature
Rating: -40 to 85°C
Package in Tape & Reel

Order, Mark & Packing information

Package	Vout(V)	Product ID	Marking	Packing
TSOT-23-6	Adjustable	EML3172-00VT06NRR		Tape & Reel 3K units

Functional Block Diagram

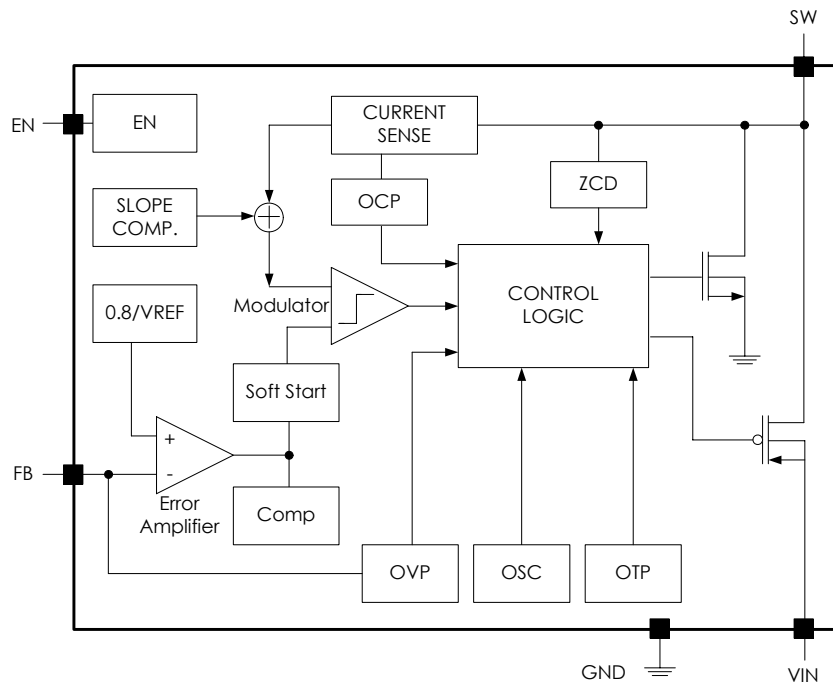

Fig. 2

Pin Functions

Pin Name	TDFN-8L	Function
EN	1	Enable Pin. Chip enable pin (1:Enable ; 0:Disable).
GND	2	Power Switch Ground Pin.
SW	3	Switch Pin. Must be connected to Inductor. This pin connects to the drains of the internal main and synchronous power MOSFET switches.
VIN	4	Power Supply Pin. Must be closely decoupled to GND pin with 22 μ F*2 or greater ceramic capacitor.
NC	5	No Connect Pin No internal connect.
FB	6	Feedback Pin. Receives the feedback voltage from an external resistive divider across the output.

Absolute Maximum Ratings

Devices are subjected to fail if they stay above absolute maximum ratings.

Input Voltage (VIN) -----	-0.3V to 6.0V	Operating Temperature Range ----	-40°C to 85°C
EN, FB Voltages -----	-0.3V to VIN	Junction Temperature (Note 1) -----	150°C
SW Voltage -----	-0.3V to (VIN + 0.3V)	Storage Temperature Range -----	-65°C to 150°C
Lead Temperature (Soldering, 10 sec)-----	260°C		

Thermal data

Package	Thermal resistance	Parameter	Value
TSOT-23-6	θ_{JA} (Note 2)	Junction-ambient	110°C/W
	θ_{JT} (Note 3)	Junction-top of package	8.5°C/W

Electrical Characteristics

V_{IN}=V_{VCC}=V_{EN}=3.6V, V_{OUT}=1.2V, V_{FB}=0.8V, L=2.2uH, C_{IN}=22uF, C_{OUT}=22uF, T_A = 25°C, unless otherwise noted.

Symbol	Parameter	Conditions	Min	Typ	Max	Units
V _{IN}	Input Voltage Range		2.5		5.5	V
I _Q	Supply Current V _{IN} =3.6V	Switching (EN=VCC)		220		μA
		Shutdown (EN=0)			1	μA
UVLO	Under Voltage Lockout	When SW starts/stops switching	1.8		2.1	V
V _{ref}	Reference Voltage	V _{IN} = 2.5V to 5.0V	0.784	0.8	0.816	V
V _{EN}	Enable Threshold	-40°C ~ +85°C	0.4		1.5	V
V _o	Output Voltage Range	When using external feedback resistors to drive FB	0.8		V _{IN}	V
V _{out}	Output Voltage Accuracy	2.5V ≤ V _I ≤ 5.5V, 0mA ≤ I _o ≤ 3A	0.97xV _{NOM}	V _{NOM}	1.03xV _{NOM}	V
ΔV _{OUT} /ΔV _{OU}	Line Regulation	V _{OUT} = 1.2V, V _{IN} = 2.5V to 5.0V, I _{OUT} =10mA		0.04		%/V
ΔV _{OUT} /ΔI _{OUT}	Load Regulation	I _{out} = 1mA to 3.0A		0.01		%/A
R _{ON(P)}	R _{DS(ON)} of PMOS	I _{OUT} =100mA		60		mΩ
R _{ON(N)}	R _{DS(ON)} of NMOS	I _{OUT} =100mA		50		mΩ
I _{oCH}	High Side Current Limit	Duty Cycle = 100%, V _{IN} = 2.5V to 5.0V	3.75	4.5	6	A
I _{oCL}	Low Side Current Limit			-0.6		
F _{OSC}	Oscillator Frequency	V _{FB} =0.8V, -40°C~+85°C	1.12	1.4	1.68	MHz
Max. Duty	Maximum Duty	V _{IN} = 2.5V to 5.0V	100			%
Min. Duty	Minimum Duty.			15		
OTP	Thermal Shutdown	Hysteresis=35°C		165		°C

Note 1: T_J is a function of the ambient temperature T_A and power dissipation P_D (T_J = T_A + (P_D) * θ_{JA})).

Note 2: θ_{JA} is measured in the natural convection at T_A=25°C on a highly effective thermal conductivity test board(2 layers , 2SOP) according to the JEDEC 51-7 thermal measurement standard.

Note 3: θ_{JT} represents the heat resistance between the chip and the center of package top, that's obtained by simulating a cold plate test on the top of the package.

Typical Performance Characteristics

$V_{IN}=5.0V$, $T_A=25^\circ C$, $L=2.2\mu H$, $C_{IN}=22\mu F$, $C_{OUT}=22\mu F$, unless otherwise specified

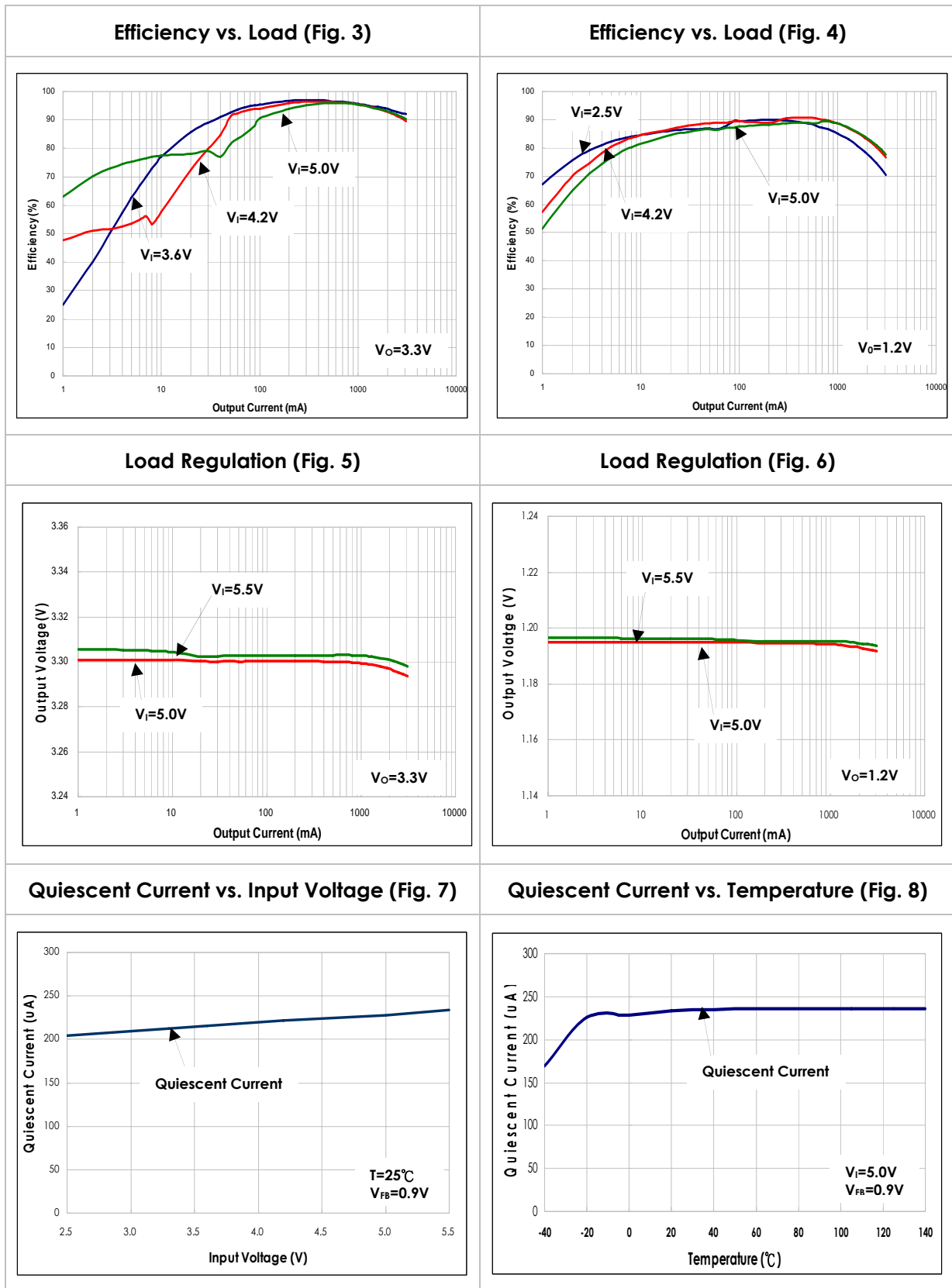

Typical Performance Characteristics

$V_{IN}=5.0V$, $T_A=25^\circ C$, $L=2.2\mu H$, $C_{IN}=22\mu F$, $C_{OUT}=22\mu F$, unless otherwise specified

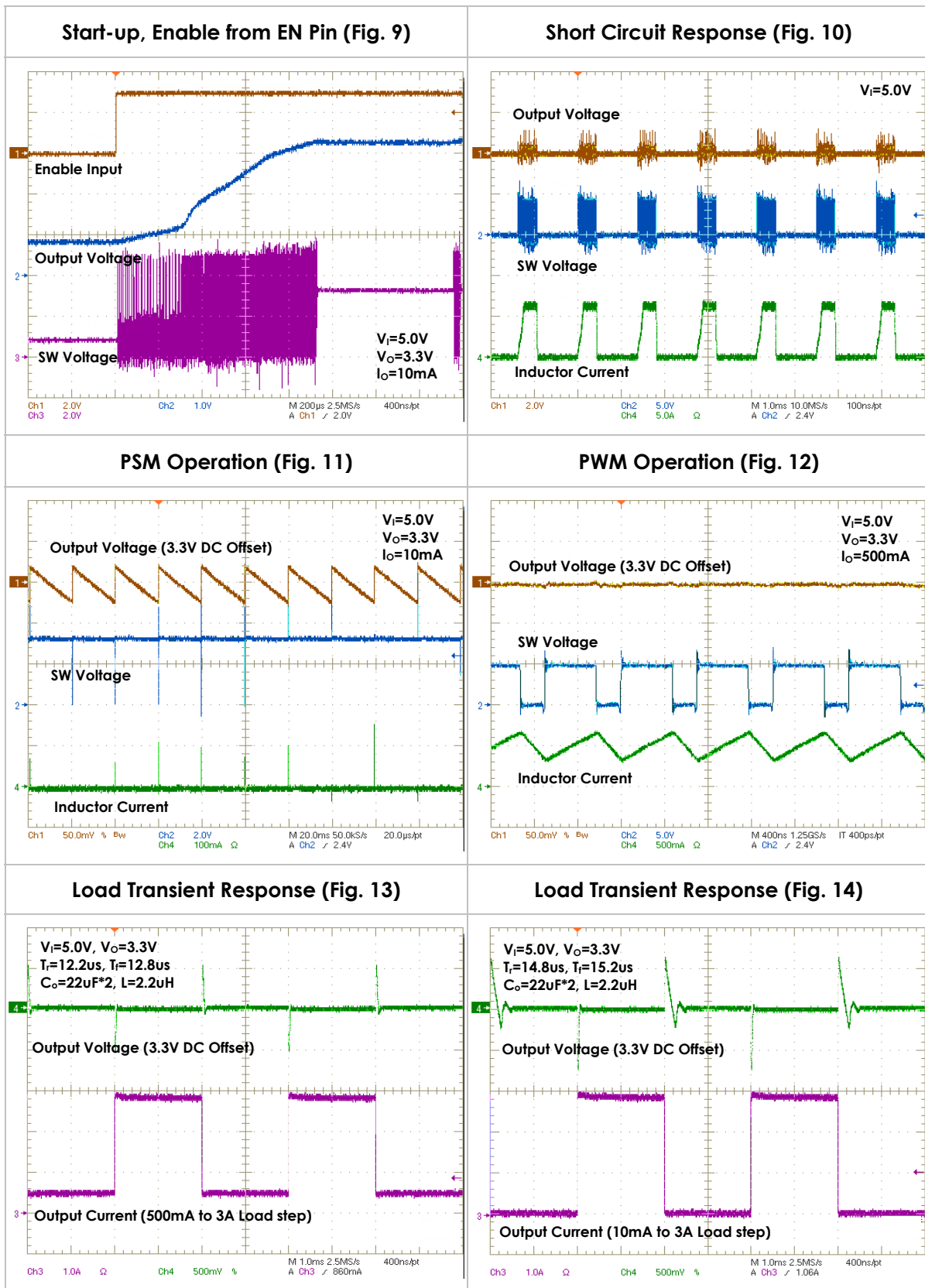

Typical Performance Characteristics

$V_{IN}=5.0V$, $T_A=25^\circ C$, $L=2.2\mu H$, $C_{IN}=22\mu F$, $C_{OUT}=22\mu F$, unless otherwise specified

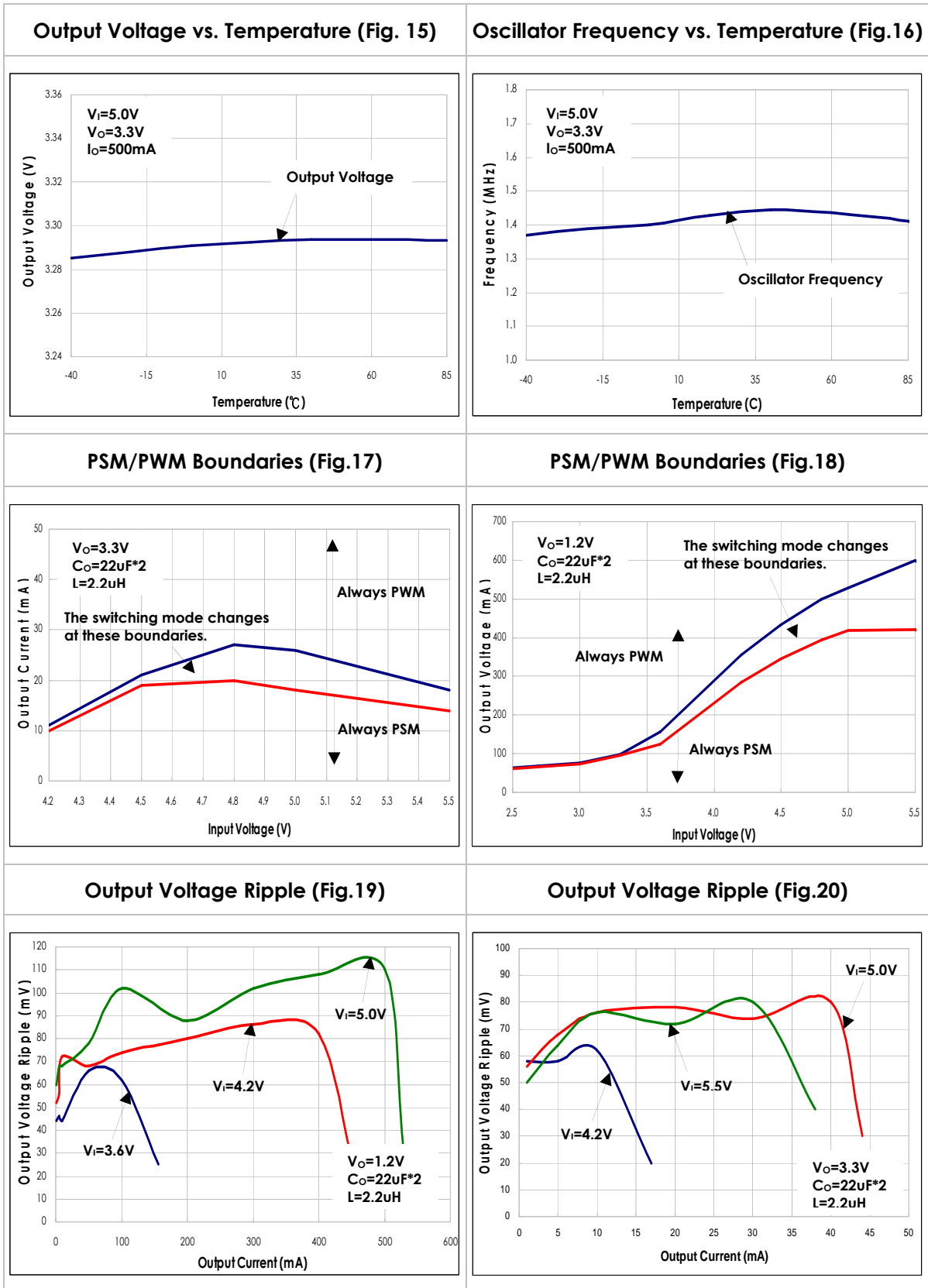

Application Information

Detailed Description

The EML3172 is a synchronous, step-down DC/DC converter. It allows up to 3A current output with adjustable output voltage. Throughout the entire operating range, EML3172 can maintain high efficiency using both PWM (heavy load) and PSM (light load) modes with very small output voltage ripple performance.

During normal operation, the internal oscillator sends a pulse signal to set latch to turn on/off internal high-side MOSFET and low-side MOSFET during each clock cycle. When the current-mode ramp signal which is the sum of internal high-side MOSFET current and slope compensation ramp exceeds output voltage of error amplifier, the PWM comparator will send a signal to reset latch and turn off/on internal high-side MOSFET/low-side MOSFET. The error amplifier adjusts its output voltage by comparing the reference voltage and the feedback voltage.

The basic EML3172 application circuits are shown as in Figure 1, External components selection is determined by the load current and is critical with the selection of inductor and capacitor values.

PSM

In order to increase light load efficiency, save switching loss is used in EML3172. During in light load, the device only switching when output voltage is below the pre-set threshold. This function can skip some switching cycle that save unnecessary loss. The fig.11 illustrates, as the loading increases, the operation frequency increases until IC goes into normal operation frequency 1.4MHz. The fig.11 and fig.12 illustrate the difference between PSM and PWM output voltage ripple. The switching frequency and output ripple is dependant on factors such as loading, inductor and output capacitance. Besides, the input and output voltage ratio is a factor which affects device going PSM mode or not. Reference fig.17, as input voltage decreases, PSM/PWM boundary decreases to close 0mA. Keep light load in PSM, $V_{IN} > V_{OUT} + 1V$ is necessary.

Inductor Selection

The value of the inductor is selected based on the desired ripple current. Large inductance gives low inductor ripple current and small inductance result in high ripple current. However, the larger value inductor has a larger physical size, higher series resistance, and/or lower saturation current. In experience, the value is to allow the peak-to-peak ripple current in the inductor to be 10%~20% maximum load current. The inductance value can be calculated by:

$$L = \frac{(V_{IN} - V_{OUT}) * \frac{V_{OUT}}{V_{IN}}}{F_{OSC} * \Delta I_L} = \frac{(V_{IN} - V_{OUT})}{F_{OSC} * (2 * (10\% \sim 20\%) * I_{LOAD})} * \frac{V_{OUT}}{V_{IN}}$$

The inductor ripple current can be calculated by:

$$\Delta I_L = \frac{V_{OUT}}{F_{OSC} * L} * \left(1 - \frac{V_{OUT}}{V_{IN}} \right)$$

Choose an inductor that does not saturate under the worst-case load conditions, which is the load current plus half the peak-to-peak inductor ripple current, even at the highest operating temperature. The peak inductor current is:

$$I_{L_PEAK} = I_{LOAD} + \frac{\Delta I_L}{2}$$

The inductors in different shape and style are available from manufacturers. Shielded inductors are small and radiate less EMI issue. But they cost more than unshielded inductors. The choice depends on EMI requirement, price and size.

Recommend Table

Inductor Value (μH)	Dimensions (mm)	Component Supplier	Model	ISAT (A)	DCR (mΩ)
1.5	5.2 x 4.9 x 3.0 max.	CYNTEC	PCMB053T-2R5MS	10	20 typ.
1.5	4.9 x 4.9 x 4.1 max.	TAIYO YUDEN	NRS5040T1R5NMGJ	6.4	22.1 typ.
2.2	5.2 x 4.9 x 3.0 max.	CYNTEC	PCMB053T-2R2MS	9	29 typ.
2.2	4.9 x 4.9 x 4.1 max.	TAIYO YUDEN	NRS5040T2R2NMGJ	5	28.6 typ.

Input Capacitor Selection

The input capacitor must be connected to the VIN pin and GND pin of EML3172 to maintain steady input voltage and filter out the pulsing input current. The voltage rating of input capacitor must be greater than maximum input voltage plus ripple voltage. In normal operation, the input current is discontinuous in a buck converter. The source current waveform of the high-side MOSFET is a square wave. To prevent large voltage transients, a low ESR input capacitor sized for the maximum RMS current must be used. The RMS value of input capacitor current can be calculated by:

$$I_{RMS} = I_{LOAD_MAX} * \sqrt{\frac{V_{OUT}}{V_{IN}} * \left(1 - \frac{V_{OUT}}{V_{IN}}\right)}$$

It can be seen that when V_O is half of V_{IN} , C_{IN} is under the worst current stress. The worst current stress on C_{IN} is $I_{O_MAX}/2$. A 22μF*2ea ceramic capacitor is recommended value in typical application.

Output Capacitor Selection

The output capacitor is required to maintain the DC output voltage. Low ESR capacitors are preferred to keep the output voltage ripple low. In a buck converter circuit, output ripple voltage is determined by inductor value, switching frequency, output capacitor value and ESR. The output ripple is determined by:

$$\Delta V_{OUT} = \Delta I_L * \left(ESR_{COUT} + \frac{1}{8 * F_{OSC} * C_{OUT}} \right)$$

Where F_{OSC} = operating frequency, C_{OUT} = output capacitance and ΔI_L = ripple current in the inductor. For a fixed output voltage, the output ripple is highest at maximum input voltage since ΔI_L increases with input voltage. A 22 μ F ceramic capacitor is recommended value in typical application.

Recommend Table

Capacitor Value (μ F)	Case Size	Component Supplier	Model
22	0805 1206	TDK	C3216X5R1E226K

Using Ceramic Input and Output Capacitors

Care must be taken when ceramic capacitors are used at the input and the output. When a ceramic capacitor is used at the input and the power is supplied by a wall adapter through long wires, a load step at the output can induce ringing at the input, V_{IN} . At best, this ringing can couple to the output and be mistaken as loop instability. At worst, a sudden inrush current through the long wires can potentially cause a voltage spike at V_{IN} , which may large enough to damage the part. When choosing the input and output ceramic capacitors, choose the X5R or X7R specification. Their dielectrics have the best temperature and voltage characteristics of all the ceramics for a given value and size.

Load Transient

A switching regulator typically takes several cycles to respond to the load current step. When a load step occurs, V_{OUT} immediately shifts by an amount equal to

$$\Delta I_{LOAD} * ESR_{COU\!T}$$

ESR is the effective series resistance of output capacitor. ΔI_{LOAD} also begins to charge or discharge C_{OUT} generating a feedback error signal used by the regulator to return V_{OUT} to its steady-state value. During the recovery time, V_{OUT} can be monitored for overshoot or ringing that would indicate a stability problem.

Short-Circuit Protection

When EML3172 output node is shorted to GND, chip will enter soft-start to protect itself, when short circuit is removed, EML3172 enter normal operation again. If EML3172 reach OCP threshold while short circuit, EML3172 will enter soft-start cycle until the current under OCP threshold.

Over Temperature Protection

The internal high-side MOSFET is turned off when the internal thermal sensor detects that the junction temperature exceeds 165 $^{\circ}$ C, entering the Over Temperature Protection mode (OTP). The OTP mode is unlocked at 130 $^{\circ}$ C, i.e. 35 $^{\circ}$ C hysteresis.

Output Voltage Setting

The output voltage of EML3172 can be adjusted by a resistive divider according to the following formula:

$$V_{OUT} = V_{REF} * \left(1 + \frac{R_1}{R_2}\right) = 0.8 * \left(1 + \frac{R_1}{R_2}\right)$$

The resistive divider senses the fraction of the output voltage as shown in Fig.21. Using large feedback resistor can increase efficiency, but too large value affects the device's output accuracy because of leakage current going into device's FB pin. The recommended value for R2 is therefore in the range of 50KΩ.

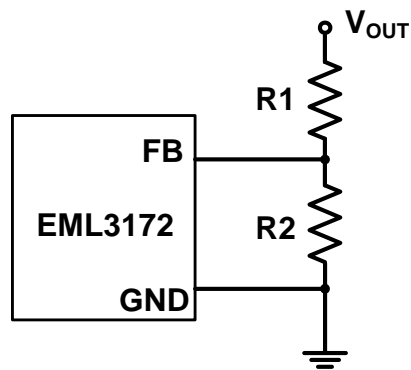

Fig. 21 Setting the Output Voltage

Under Voltage Lock Out

The under-voltage lockout (UVLO) circuitry ensures that the EML3172 starts up with adequate voltage. The regulator output is disabled whenever VIN is below UVLO. The hysteresis of UVLO is designed to be 100 mV.

Application Circuits Information

■ **Application circuit for maximum 2A load**

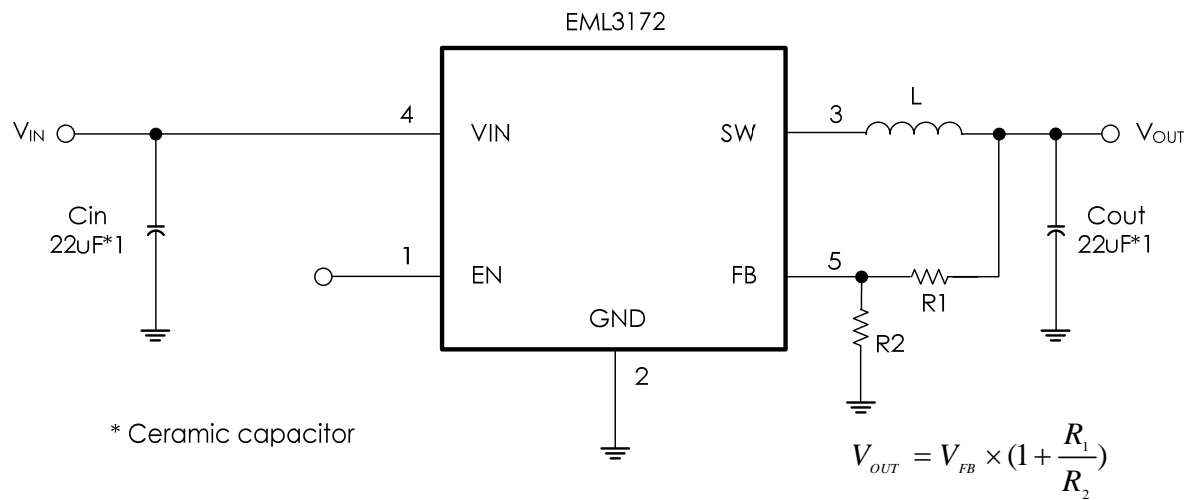

Note. It's recommended that $C_{IN}=22\mu F \times 2ea$ for short protection circuit work sell considering at low temperature lower than $-20^{\circ}C$.

Recommended component selection,

Vout	R1	R2	L	Cin	Cout
3.3V	75KΩ	24KΩ	1.5µH	22µF	22µF
2.5V	51KΩ	24KΩ	1.5µH	22µF	22µF
1.8V	15KΩ	12KΩ	2.2µH	22µF	22µF
1.2V	10KΩ	20KΩ	2.2µH	22µF	22µF
1.0V	30KΩ	120KΩ	2.2µH	22µF	22µF

■ **Application circuit for maximum 3A load**

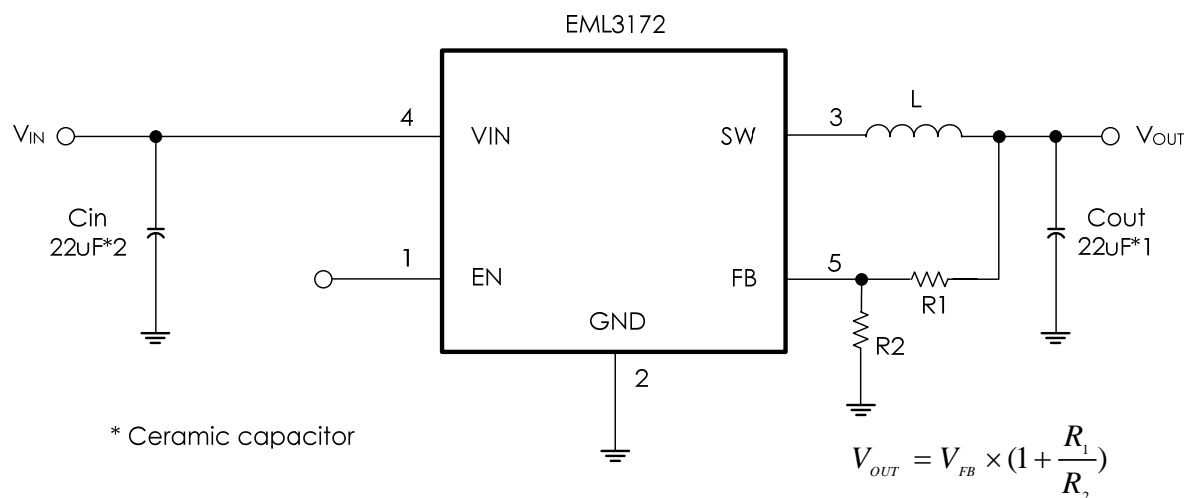

Note. It's recommended that $C_{OUT}=22\mu F \times 2ea$ for load regulation considering application.

Applications

Typical Schematic for PCB layout

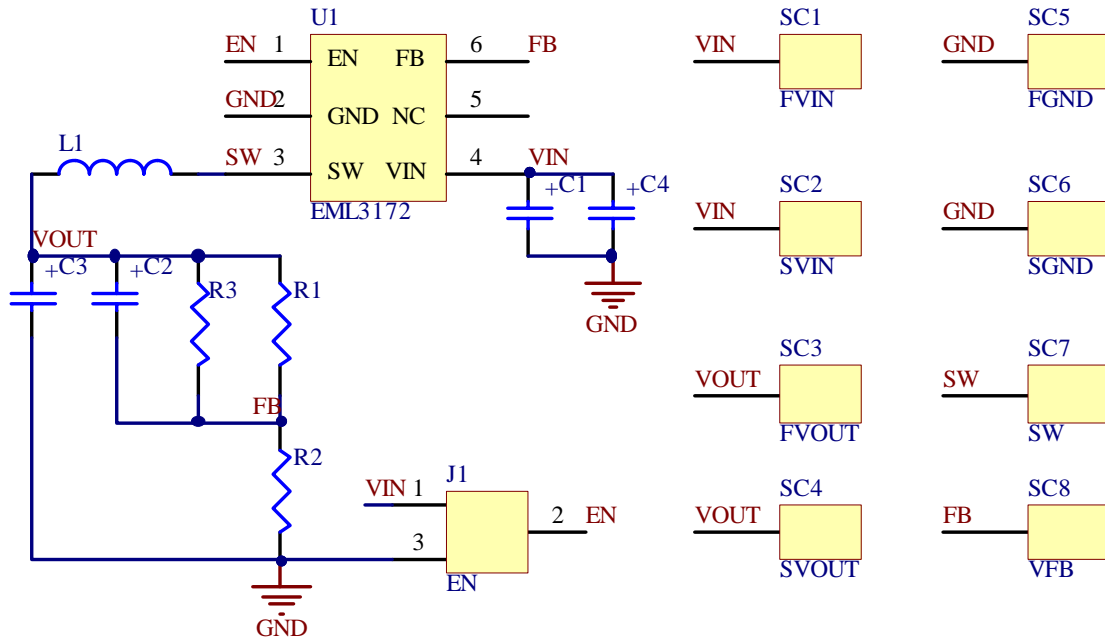

Fig. 22

PCB Layout Guidelines

When laying out the printed circuit board, the following checklist should be used to optimize the performance of EML3172.

1. The power traces, including the GND trace, the SW trace and the V_{IN} trace should be kept direct, short and wide.
2. Put input capacitor as close as possible to the V_{IN} and GND pins.
3. The FB pin should be connected directly to the feedback resistor divider.
4. Keep the switching node, SW, away from the sensitive FB pin and the node should be kept small area.

Typical Schematic for PCB layout (cont.)

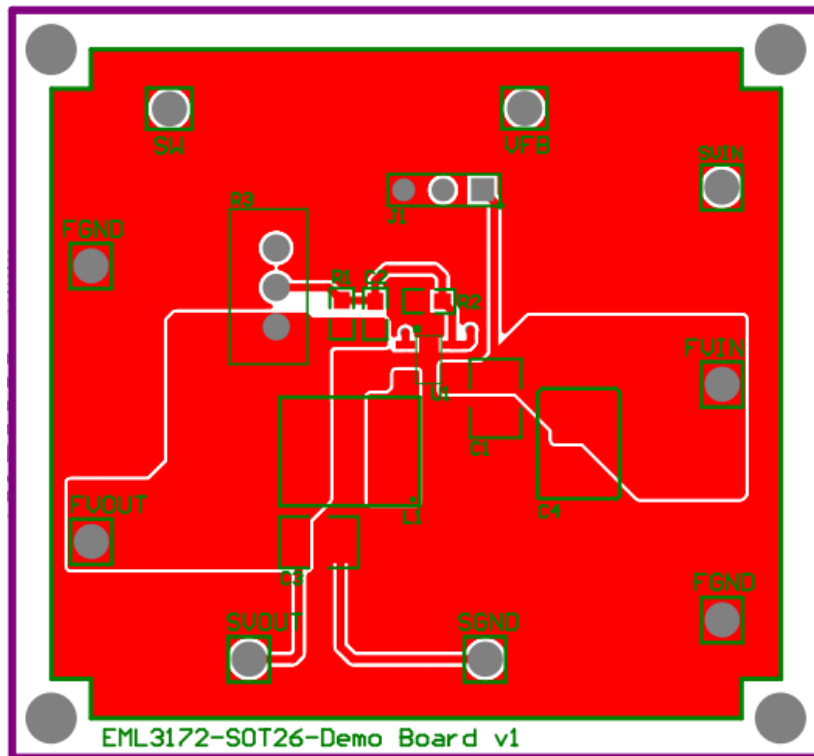

Top Layer

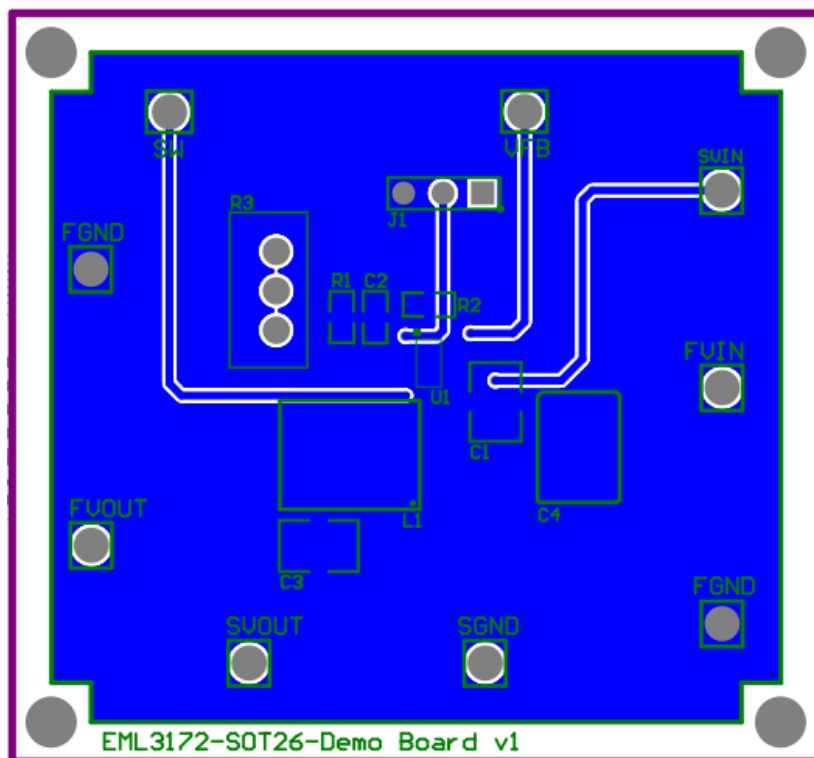

Bottom Layer

Package Outline Drawing
TSOT-23-6

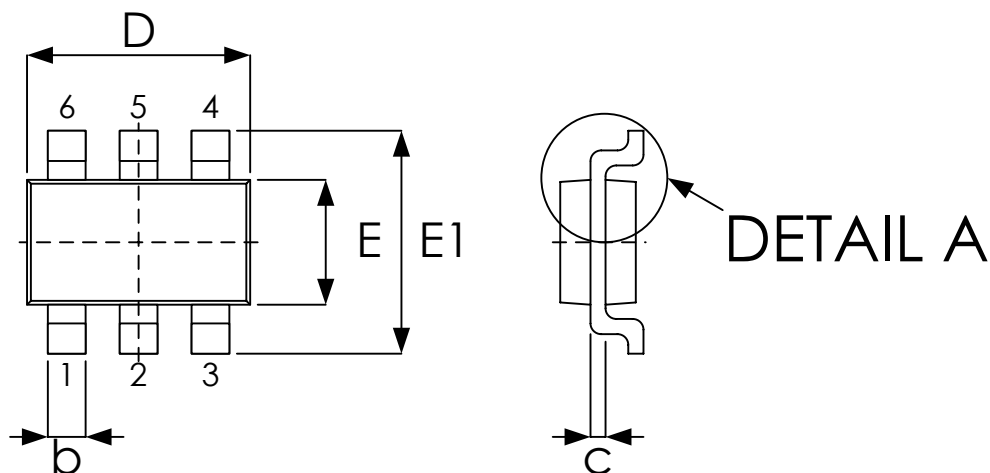

TOP VIEW

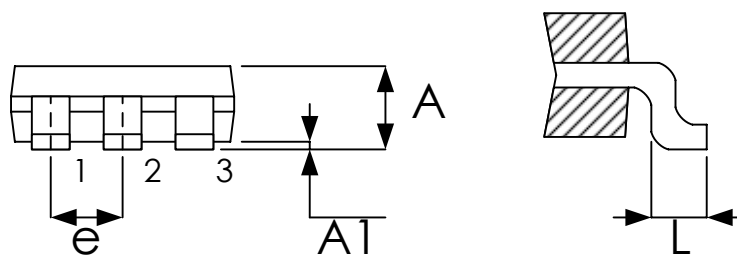

SIDE VIEW

DETAIL A

Symbol	Dimension in mm	
	Min.	Max.
A	0.90	1.45
A1	0.00	0.15
b	0.30	0.50
c	0.08	0.25
D	2.70	3.10
E	1.40	1.80
E1	2.60	3.00
e	0.95 BSC	
L	0.30	0.60

Revision History

Revision	Date	Description
0.1	2013.12.27	Draft version.
1.0	2015.03.11	Revise version to 1.0 & remove preliminary word
1.1	2015.03.24	Updated typical application circuit in page 1. Added the recommended components selection.

Important Notice

All rights reserved.

No part of this document may be reproduced or duplicated in any form or by any means without the prior permission of ESMT.

The contents contained in this document are believed to be accurate at the time of publication. ESMT assumes no responsibility for any error in this document, and reserves the right to change the products or specification in this document without notice.

The information contained herein is presented only as a guide or examples for the application of our products. No responsibility is assumed by ESMT for any infringement of patents, copyrights, or other intellectual property rights of third parties which may result from its use. No license, either express, implied or otherwise, is granted under any patents, copyrights or other intellectual property rights of ESMT or others.

Any semiconductor devices may have inherently a certain rate of failure. To minimize risks associated with customer's application, adequate design and operating safeguards against injury, damage, or loss from such failure, should be provided by the customer when making application designs.

ESMT's products are not authorized for use in critical applications such as, but not limited to, life support devices or system, where failure or abnormal operation may directly affect human lives or cause physical injury or property damage. If products described here are to be used for such kinds of application, purchaser must do its own quality assurance testing appropriate to such applications.