

2A, 23V, 340KHz Synchronous Step-Down Converter

General Description

The EML3220 is a synchronous step-down DC/DC converter that provides wide 4.5V to 23V input voltage range and 2A continuous load current capability.

Fault protection includes cycle-by-cycle current limit, input UVLO, output over voltage protection and thermal shutdown. Besides, adjustable soft-start function prevents inrush current at turn-on. This device uses current mode control scheme that provides fast transient response. In shutdown mode, the supply current is about 10uA.

The EML3220 is available in an 8-pin SOP package, provides a very compact system solution and good thermal conductance.

Features

- Wide Input Voltage from 4.5V to 23V

- 2A Output Current
- Adjustable Output Voltage from 0.925V to 20V
- 130mΩ integrated Power MOSFET
- High Efficiency Up to 93%
- Fixed 340KHz Switching Frequency
- Current Mode Operation
- Adjustable Soft-Start
- Cycle-by-Cycle current limit
- Input Under Voltage Lockout
- Over-Temperature Protection
- Thermal Enhanced SOP-8 Package
- RoHS Compliant

Applications

- Set-Top-Box
- DVD, LCD Displays
- OLPC, Netbook
- Distributed Power System
- Datacom, XDSL

Typical Application

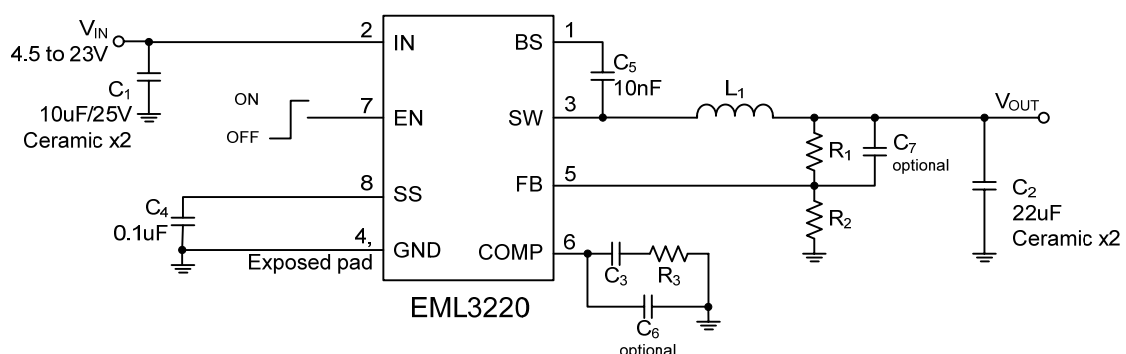
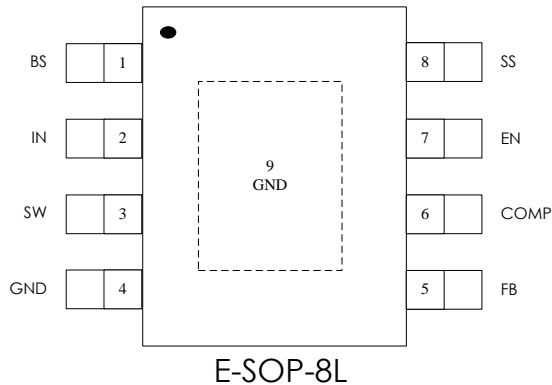

Fig. 1

Package Configuration



EML3220-00SG08NRR
 00 Adjustable
 SG08 E-SOP-8L Package
 NRR RoHS & Halogen free package
 Commercial Grade Temperature
 Rating: -40 to 85°C
 Package in Tape & Reel

Order, Mark & Packing information

Package	Vout(V)	Product ID	Marking	Packing
E-SOP-8L	adjustable	EML3220-00SG08NRR		Tape & Reel 3K units

Functional Block Diagram

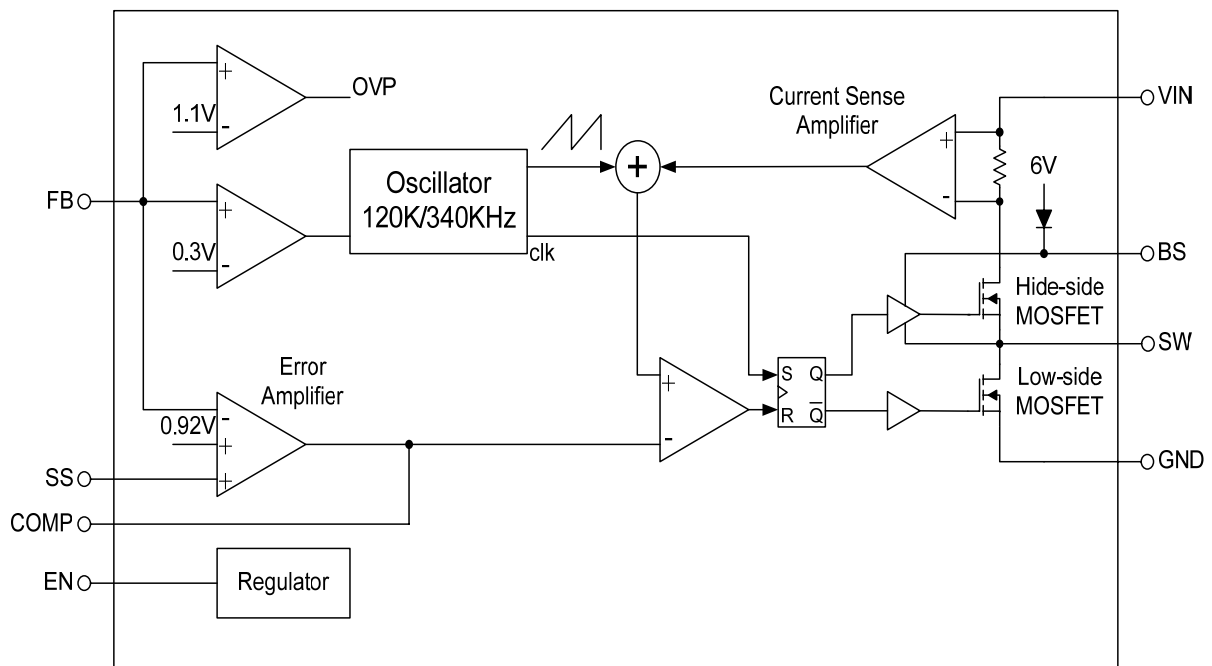

Fig. 2

Pin Functions

Pin Name	E-SOP-8L	Function
BS	1	Bootstrap. A 10nF or greater capacitor must be connected from this pin to SW. It can boost the gate drive to fully turn on the internal high side NMOS.
IN	2	Power Input Pin. Drive 4.5V to 23V voltage to this pin to power on this chip. Connecting a 10uF ceramic bypass capacitor between V_{IN} and GND to eliminate noise.
SW	3	Switch Pin. Must be connected to Inductor. This pin connects to the drains of the internal main and synchronous power MOSFET switches.
GND	4	Ground Pin.
FB	5	Feedback Pin. Receives the feedback voltage from an external resistive divider across the output, it regulates at 0.925V.
COMP	6	Compensation. This pin is used to compensate the regulation control loop. Connect a series RD network from COMP pin to GND.
EN	7	Enable Pin. This pin provides a digital control to turn the converter on or off. Connect to V_{IN} with a 100K Ω resistor for self-startup.
SS	8	Soft-start. This pin controls the soft-start period. Connect a capacitor from SS to GND to set the soft start period. To disable the soft-start feature, leave SS unconnected.
Exposed pad	9	Thermal pad. Connect to GND.