

---

# Standalone Linear Li-Ion Charger (two-cell) with Thermal Regulation

---

## General Description

The EMC5042 is a complete linear charger for two-cell lithium-ion batteries. With small TDFN-10 package and few external components, EMC5042 is well suited for portable applications.

No external sense resistor and blocking diode are required. Charging current can be programmed externally with a single resistor. The built-in thermal regulation facilitates charging with maximum power without risk of overheating.

The EMC5042 always preconditions the battery with 1/10 of the programmed charge current at the beginning of a charge cycle, after it verifies that the battery can be fast-charged. The EMC5042 automatically terminates the charge cycle when the charge current drops to 1/10th the programmed value after the final float voltage is reached.

The EMC5042 features 13.5V maximum rating voltage for AC adapter, and it provides the charge current up to 1.2A. Other features include battery temperature monitoring, reverse current protection, shutdown mode, charging current monitor, under voltage lockout, automatic recharge and status indicator.

## Features

- Programmable charge current up to 1.2A
- No MOSFET, sense resistor or blocking diode required
- Complete linear charger in TDFN-10 for two-cell li-ion batteries
- Thermal regulation maximizes charge rate without risk of overheating
- Thermistor input for temperature qualified charging
- Preset 8.4V charge voltage with  $\pm 1\%$  accuracy
- Automatic recharge
- Charge status indicator
- C/10 charge termination
- 5.8V trickle charge threshold
- Battery reverse leakage current less than 1uA

## Applications

- Wireless handsets
- Hand-held instruments
- Portable information appliances

## Typical Application Circuit

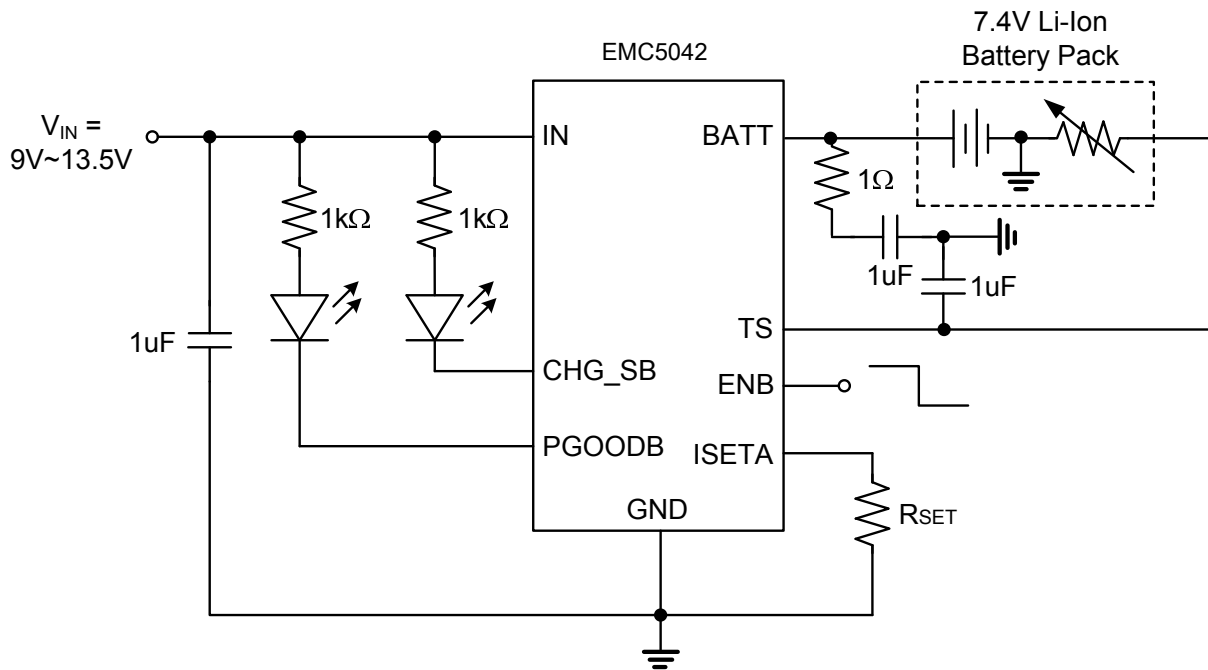

## Complete Charger Cycle

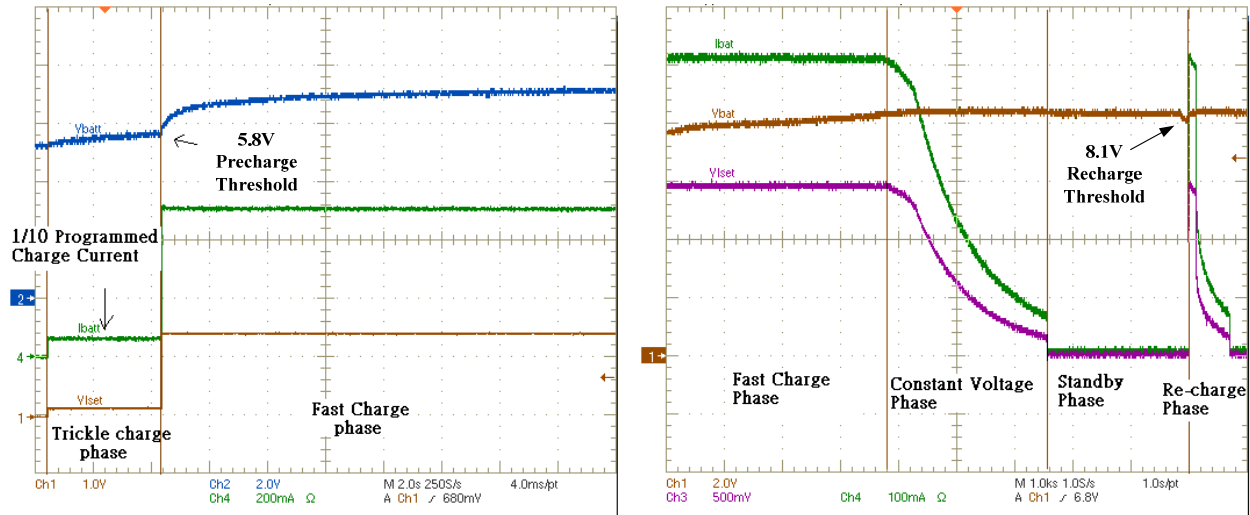

## Connection Diagrams

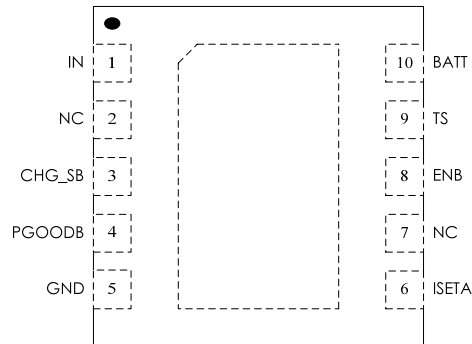

Top View

## Order information

EMC5042-84FF10NRR  
 84 Output voltage  
 FF10 TDFN-10 Package  
 NRR RoHS & Halogen free package  
 Rating: -40 to 85°C  
 Package in Tape & Reel

## Order, Marking & Packing Information

Package	Product ID.	Marking	Packing
TDFN-10 (3x3 mm)	EMC5042-84FF10NRR		Tape & Reel 5Kpcs

## Pin Functions

Name	TDFN-10	Function
IN	1	<b>Positive input supply voltage.</b> Provides power to the charger, $V_{IN}$ can range from 9V to 13.5V and should be bypassed with at least a 1 $\mu$ F capacitor. When IN pin drops to within 30mV above the BATT pin voltage, the EMC5042 enters shutdown mode, dropping $I_{BATT}$ to less than 1 $\mu$ A.
NC	2	<b>Not connected.</b>
CHG_SB	3	<b>Open-Drain charge status output.</b> An internal N-channel MOSFET connects CHG_SB pin to ground when the battery is charging. After the charge cycle is completed, the internal N-channel MOSFET is replaced by a weak pull-down of approximately 25 $\mu$ A, indicating an "V <sub>IN</sub> present" condition. When the EMC5042 detects an under voltage lockout condition, CHG_SB is forced high impedance.
PGOODB	4	<b>Open-Drain battery power good output.</b> An internal N-channel MOSFET connects PGOODB pin to ground when $V_{IN}$ is reached to 8.4V. PGOODB is forced low during normal operation.
GND	5	<b>Ground.</b>
ISETA	6	<b>Charge current program, charge current monitor and shutdown pin.</b> The charge current is programmed by connecting a 1% resistor, $R_{SET}$ , to ground. When charging in constant-current mode, this pin serves to 1.5V. In all modes, the voltage on this pin can be used to measure the charge current using the following formula: $I_{BATT} = (V_{SET} / R_{SET}) * 500$ The ISETA pin can also be used to shutdown the charger. Disconnecting the program resistor from ground allows a 1 $\mu$ A current to pull the ISETA pin high. When it reaches the 2.15V shutdown threshold voltage, the charger enters shutdown mode. This pin is also clamped to approximately 2.5V. Reconnecting $R_{SET}$ to ground will return the charger to normal operation. <b>The ISETA pin must not be directly shorted to ground at any condition.</b>
NC	7	<b>Not connected.</b>
ENB	8	<b>Charge enable input (active low).</b> This pin is weakly pulled low internally.
TS	9	<b>TS pin is the input for an external NTC thermistor.</b> When the TS pin voltage is out of the window, determined by the $V_{TMIN}$ and $V_{TMAX}$ , the EMC5042 stops charging and indicates a fault condition.
BATT	10	<b>Charge current output and battery voltage feedback.</b> This pin provides charge current to the battery and regulates the final float voltage to 8.4V. An internal precision resistor divider from this pin sets the float voltage which is disconnected in shutdown mode.

Functional Block Diagram

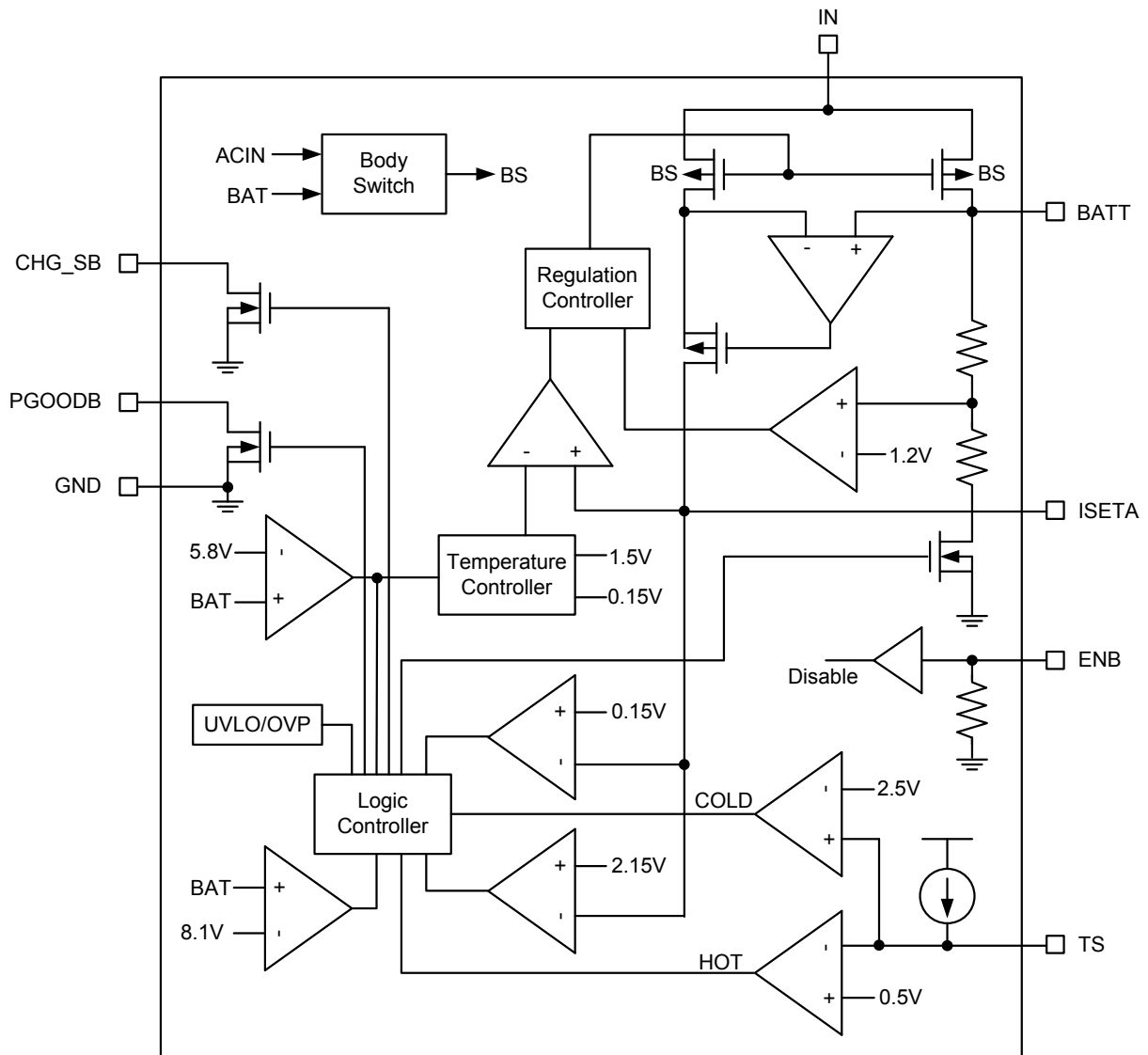

FIG.1 Functional Block Diagram of EMC5042

State Diagram

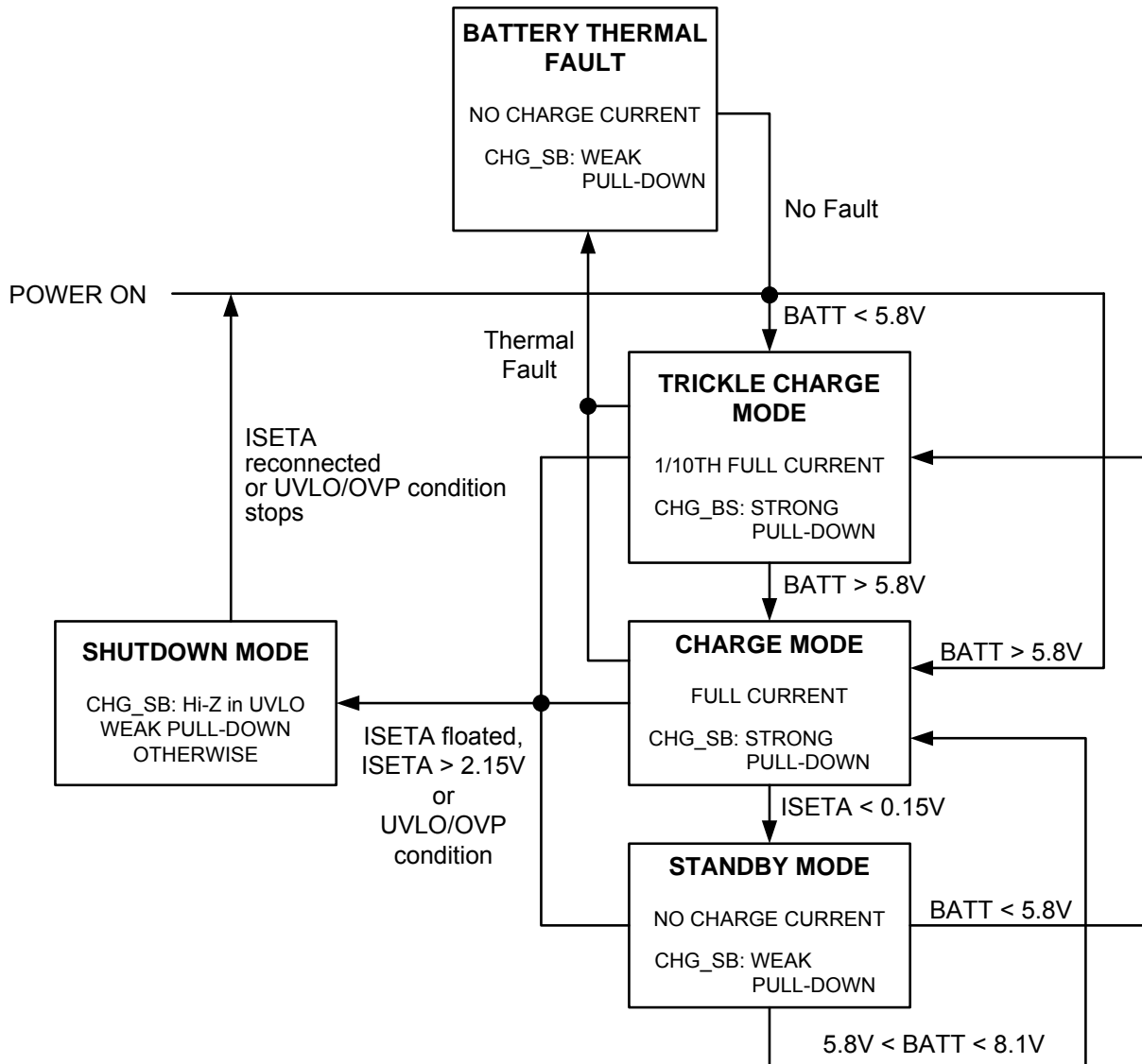

FIG.2 EMC5042 charge flow chart

## Absolute Maximum Ratings (Notes 1, 2)

$V_{IN}, V_{BATT}, V_{CHG_{SB}}, V_{PROG_{DB}}, V_{EN}$	-0.3V to 15V	Storage Temperature Range	-65°C to 150°C
$V_{ISETA}, V_{TS}$	-0.3V to 3.6V	Junction Temperature ( $T_J$ )	150°C
Power Dissipation	(Note 5)	Lead Temperature (Soldering, 10 sec.)	260°C

## Operating Ratings (Note 1, 2)

Supply Voltage	9V to 13.5V	Thermal Resistance ( $\theta_{JA}$ , Note 3))	110°C/W
Operating Temperature Range	-40°C to 85°C	Thermal Resistance ( $\theta_{JC}$ , Note 4))	8.5°C/W

## Electrical Characteristics

$T_A = 25^\circ\text{C}$ ,  $V_{IN} = 10\text{V}$ ; unless otherwise specified.

Symbol	Parameter	Conditions	Min	Typ	Max	Units
$V_{IN}$	Input Operating Voltage Range		9	10	13.5	V
$I_{CC}$	Input Supply Current	Charge Mode, $R_{SET} = 30\text{K}$ (Note 6)		300		$\mu\text{A}$
		Standby Mode (Charge Terminated)		250		$\mu\text{A}$
		Shutdown Mode ( $R_{SET}$ Not Connected, $V_{IN} < V_{BATT}$ or $V_{IN} < V_{UV}$ )		190		$\mu\text{A}$
$V_{FLOAT}$	Regulated Output (Float) Voltage	$0^\circ\text{C} \leq T_A \leq 85^\circ\text{C}$	8.316	8.4	8.484	V
$I_{BATT}$	BATT Pin Current	$R_{SET} = 1.5\text{K}$ , Current Mode		500		$\text{mA}$
		$R_{SET} = 0.75\text{K}$ , Current Mode		1000		$\text{mA}$
		Standby Mode, $V_{BATT} = 8.4\text{V}$	-1	0	1	$\mu\text{A}$
		Shutdown Mode	-1	0	1	$\mu\text{A}$
		Sleep Mode, $V_{IN} = 0\text{V}$	-1	0	1	$\mu\text{A}$
$I_{TRICKLE}$	Trickle Charge Current	$V_{BATT} < V_{TRICKLE}$ , $R_{SET} = 1.5\text{K}$		60		$\text{mA}$
		$V_{BATT} < V_{TRICKLE}$ , $R_{SET} = 0.75\text{K}$		120		$\text{mA}$
$V_{TRICKLE}$	Trickle Charge Threshold Voltage	$R_{SET} = 1.5\text{K}$ , $V_{BATT}$ Rising		5.8		V
$V_{TRHYS}$	Trickle Charge Hysteresis Voltage	$R_{SET} = 1.5\text{K}$		250		mV
$V_{MSD}$	Manual Shutdown Threshold Voltage	ISETA Pin Rising		2.15		V
		ISETA Pin Falling		2.05		V
$V_{ASD}$	$V_{IN}$ - $V_{BATT}$ Lockout Threshold Voltage	$V_{IN}$ from High to Low		30		mV
		$V_{IN}$ from Low to High		60		mV
$I_{TERM}$	C/10 Termination Current Threshold	$R_{SET} = 1.5\text{K}$		0.1		$\text{mA}/\text{mA}$
		$R_{SET} = 0.75\text{K}$		0.1		$\text{mA}/\text{mA}$
$V_{SET}$	ISETA Pin Voltage	$R_{SET} = 1.5\text{K}$ , Current Mode		1.5		V
$I_{CHG_{SB}}$	CHG_SB Pin Weak Pull-Down Current	$V_{CHG_{SB}} = 5.0\text{V}$		25		$\mu\text{A}$
$V_{CHG_{SB}}$	CHG_SB Pin Output Low Voltage	$I_{CHG_{SB}} = 5\text{mA}$		0.35		V
$V_{POG_{DB}}$	PGOODB Pin Output Low Voltage	$I_{PGOODB} = 5\text{mA}$		0.35		V

$\Delta V_{RECHRG}$	Recharge Battery Threshold Voltage	$V_{FLOAT} - V_{BATT-RECHRG}$		300		mV
$T_{ILM}$	Junction Temperature in Constant Temperature Mode (Thermal Regulation)			120		°C
$R_{ON}$	Power FET "ON" Resistance	$I_{BATT} = 500mA$		375		mΩ
$T_{RECHARGE}$	Recharge Comparator Filter Time	$V_{BATT}$ High to Low		150		us
$T_{TERM}$	Termination Comparator Filter Time	$I_{BATT}$ Falling Below $I_{CHG}/10$		1		ms
$I_{SET}$	ISETA Pin Pull-up Current			1		uA
$I_{TS}$	TS Pin Source Current	$V_{TS} = 1.5V$	96	102	108	uA
$V_{TS-COLD}$	TS Pin Cold Threshold Voltage	$V_{TS}$ Rising		2.5		V
$V_{COLD-HYS}$	TS Pin Cold Hysteresis Voltage			100		mV
$V_{TS-HOT}$	TS Pin Hot Threshold Voltage	$V_{TS}$ Falling		0.5		V
$V_{HOT-HYS}$	TS Pin Hot Hysteresis Voltage			100		mV
$V_{RUN}$	Enable Threshold				0.55	V
	Shutdown Threshold		2.8			V

**Note 1:** Absolute Maximum ratings indicate limits beyond which damage may occur. Electrical specifications do not apply when operating the device outside of its rated operating conditions.

**Note 2:** All voltages are with respect to the potential at the ground pin.

**Note 3:**  $\theta_{JA}$  is measured in the natural convection at  $T_A=25^\circ C$  on a high effective thermal conductivity test board (2 layers, 2S0P).

**Note 4:**  $\theta_{JC}$  represents the resistance to the heat flows the chip to package top case.

**Note 5:** Maximum Power dissipation for the device is calculated using the following equations:

$$P_D = \frac{T_{ILM}(\text{Thermal Regulation}) - T_A}{\theta_{JA}}$$

Where  $T_{ILM}$  is the thermal regulation temperature,  $T_A$  is the ambient temperature, and  $\theta_{JA}$  is the junction-to-ambient thermal resistance. E.g. for the TDFN-10 package  $\theta_{JA} = 110^\circ C/W$ ,  $T_{ILM} = 120^\circ C$  and using  $T_A = 25^\circ C$ , the maximum power dissipation is found to be 0.86W. The de-rating factor  $(-1/\theta_{JA}) = -9.09mW/^\circ C$ , thus below  $25^\circ C$  the power dissipation figure can be increased by 9.09mW per degree, and similarity decreased by this factor for temperatures above  $25^\circ C$ .

**Note 6:** Supply current includes ISETA pin current but does not include any current delivered to the battery through the BATT pin.



## Typical Performance Characteristics

Unless otherwise specified,  $V_{IN} = 10V$ ,  $T_A = 25^\circ C$

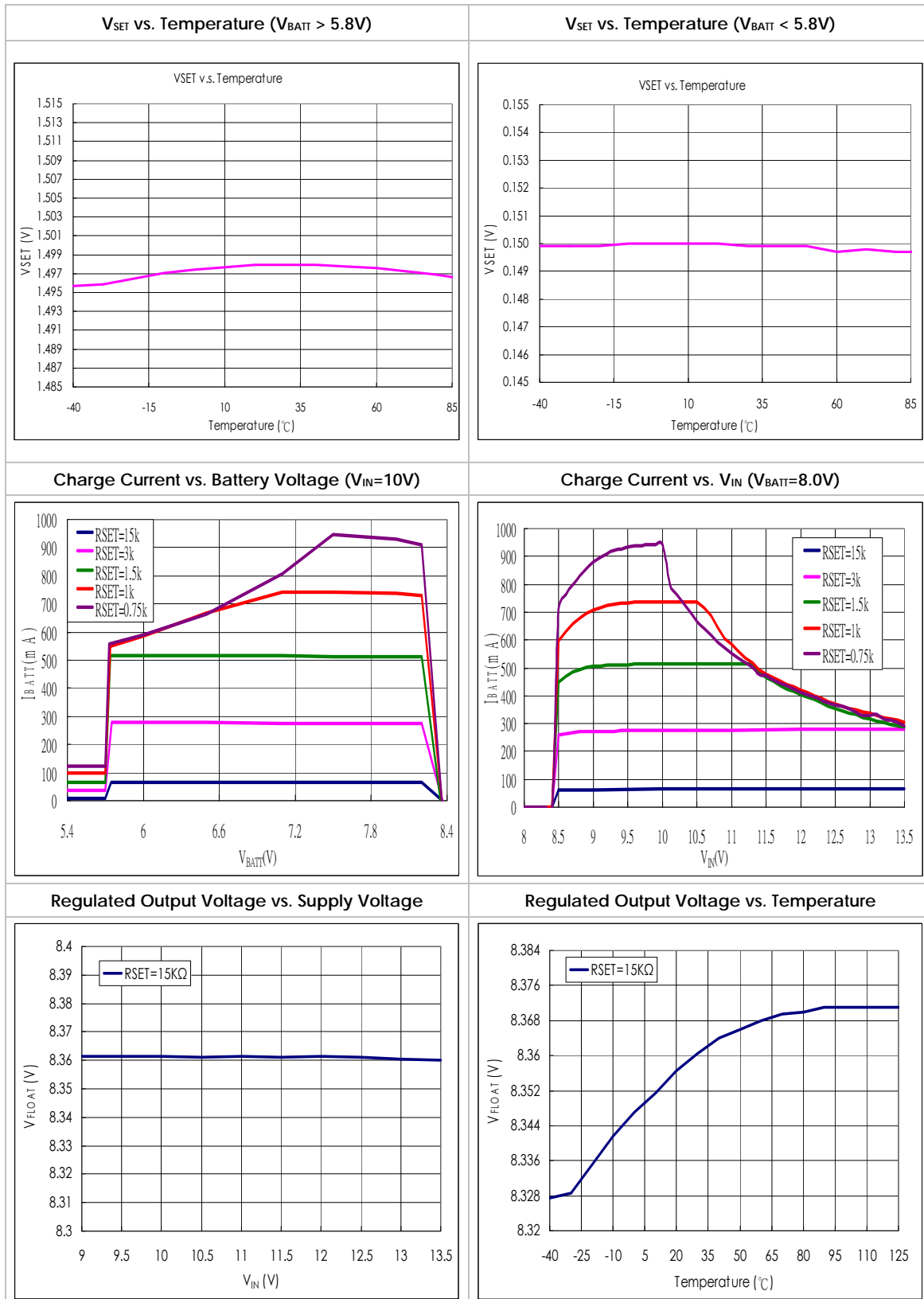

## Typical Performance Characteristics (continued)

Unless otherwise specified,  $V_{IN} = 10V$ ,  $T_A = 25^\circ C$

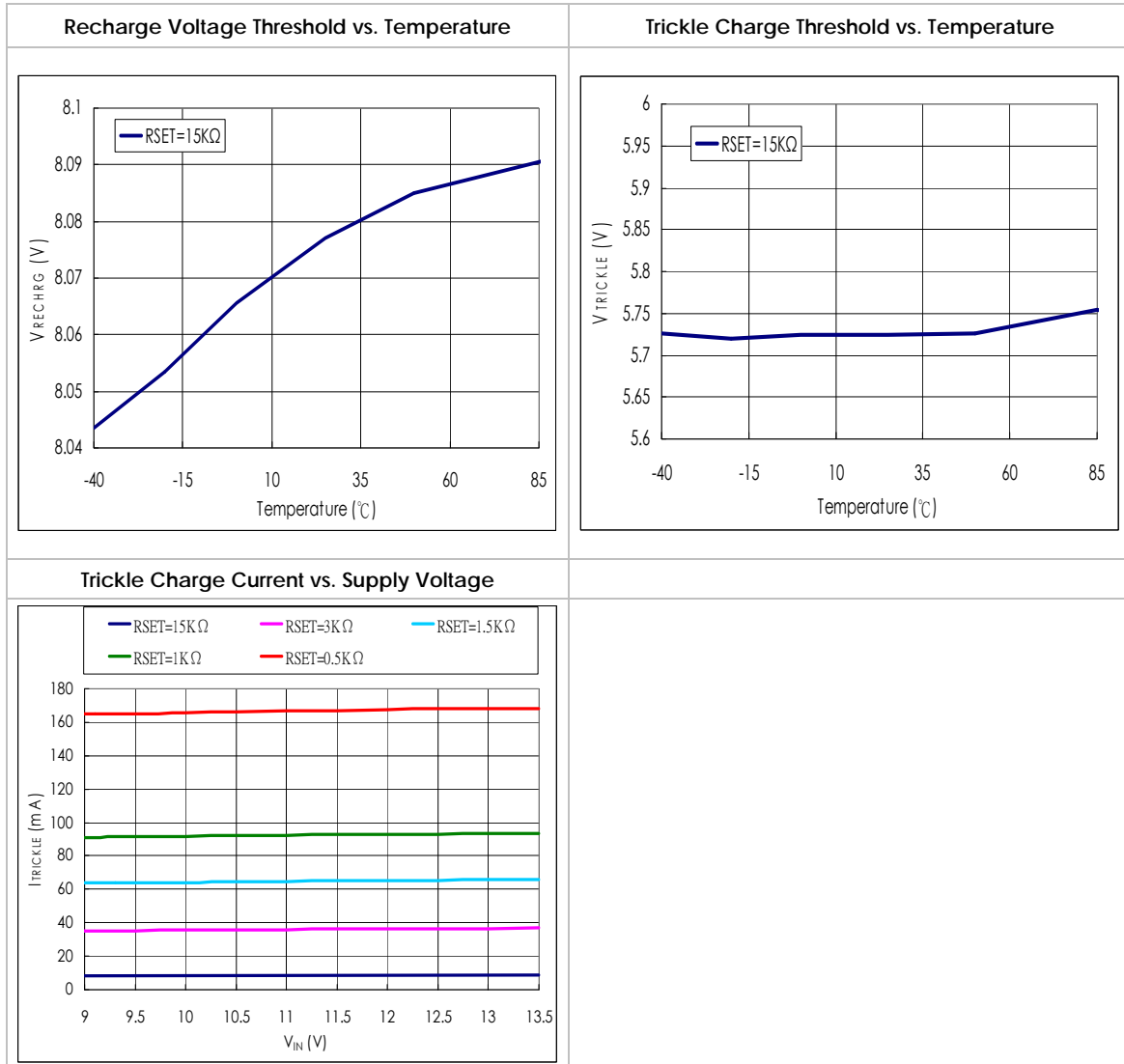

## Operation

The EMC5042 is a two-cell lithium-ion battery charger using a constant-current/constant-voltage algorithm. It can deliver up to 1.2A of charge current (using a good thermal PCB layout) with a final float voltage accuracy of  $\pm 1\%$ . The EMC5042 includes an internal P-channel power MOSFET and thermal regulation circuitry. No blocking diode or external current sense resistor is required; thus, the basic charger circuit requires only two external components.

### Normal Charge Cycle

A charge cycle begins when the voltage at the IN pin rises above the UVLO threshold level and a 1% program resistor is connected from the ISETA pin to ground or when a battery is connected to the charger output. If the BATT pin is less than 5.8V, the charger enters trickle charge mode. In this mode, the EMC5042 supplies approximately 1/10 the programmed charge current to bring the battery voltage up to a safe level for full current charging. When the BATT pin voltage rises above 5.8V, the charger enters constant-current mode, where the programmed charge current is supplied to the battery. When the BATT pin approaches the final float voltage (8.4V), the EMC5042 enters constant-voltage mode and the charge current begins to decrease. When the charge current drops to 1/10 of the programmed value, the charge cycle ends.

### Programming Charge Current

The charge current is programmed using a single resistor from the ISETA pin to ground. The battery charge current is 500 times the current out of the ISETA pin.  $V_{SET}$  is 1.5V when charging in constant-current mode. The program resistor and the charge current are calculated using the following equations:

$$R_{SET} = \frac{500V_{SET}}{I_{CHG}}, \quad I_{CHG} = \frac{500V_{SET}}{R_{SET}}$$

The charge current out of the BATT pin can be determined at any time by monitoring the ISETA pin voltage using the following equation:

$$I_{BATT} = \frac{V_{SET}}{R_{SET}} \times 500$$

### Charge Termination

A charge cycle is terminated when the charge current falls to 1/10th the programmed value after the final float voltage is reached. This condition is detected by using an internal, filtered comparator to monitor the ISETA pin. When the ISETA pin voltage falls below 150mV for longer than  $T_{TERM}$  (typically 1ms), charging is terminated. The charge current is latched off and the EMC5042 enters standby mode, where the input supply current drops to 150uA. (Note: C/10 termination is disabled in trickle charging and thermal limiting modes). The EMC5042 draws no current from the battery in standby mode. This feature reduces the charge and discharge cycles on the battery, further prolonging the battery life.

Any external source ( $V_{SET}$ ) that holds the ISETA pin above 150mV will prevent the EMC5042 from terminating a charge cycle. However, if the ISETA pin is controlled by external source, current sourcing from the BATT pin can be infinity (until the internal power MOSFET is burned out or the BATT pin voltage is close to its final float voltage), and the formula for charge current is not valid anymore.

When charging, transient loads on the BATT pin can cause the ISETA pin to fall below 150mV for short periods of time before the DC charge current has dropped to 1/10th the programmed value. The 1ms filter time ( $T_{TERM}$ ) on the termination comparator ensures that transient loads of this nature do not result in premature charge cycle termination. Once the average charge current drops below 1/10th the programmed value, the EMC5042 terminates the charge cycle and ceases to provide any current through the BATT pin. This is the standby mode, and all loads on the BATT pin must be supplied by the battery. In the standby mode, any signal below the manual shutdown threshold voltage (typically 2.15V) on the ISETA pin is transparent to EMC5042.

The EMC5042 constantly monitors the BATT pin voltage in standby mode. If this voltage drops below the 8.1V recharge threshold ( $V_{RECHRG}$ ), another charge cycle begins and current is once again supplied to the battery. To manually restart a charge cycle when in standby mode, the input voltage must be removed and reapplied, or the charger must be shut down and restarted using the ISETA pin.

#### Charge Status Indicator (CHG\_SB)

The charge status output has three different states: strong pull-down (~10mA), weak pull-down (~25uA) and high impedance. The strong pull-down state indicates that the EMC5042 is in a charge cycle. Once the charge cycle has terminated, the pin state is determined by under-voltage lockout conditions. A weak pull-down indicates that  $V_{IN}$  meets the UVLO conditions and the EMC5042 is ready to charge. High impedance indicates that the EMC5042 is in under-voltage lockout mode: either  $V_{IN}$  is less than 60mV of the BATT pin voltage or insufficient voltage is applied to the IN pin. A microprocessor can be used to distinguish between these three states. This method is discussed in the Applications Information section.

#### Thermal Limiting

An internal thermal feedback loop reduces the programmed charge current if the die temperature attempts to rise above a preset value of approximately 125°C. This feature protects the EMC5042 from excessive temperature and allows the user to push the limits of the power handling capability of a given circuit board without risk of damaging the EMC5042. The charge current can be set according to typical (not worst-case) ambient temperature with the assurance that the charger will automatically reduce the current in worst-case conditions. TDFN-10 package power considerations are discussed further in the Applications Information section.

#### Under-voltage Lockout (UVLO)

An internal under-voltage lockout circuit monitors the input voltage and keeps the charger in shutdown mode until  $V_{IN}$  rises above the under-voltage lockout threshold. The UVLO circuit has a built-in hysteresis of 150mV. Furthermore, to protect against reverse current in the power MOSFET, the UVLO circuit keeps the charger in shutdown mode if  $V_{IN}$  falls to within 30mV of the battery voltage. If the UVLO comparator is tripped, the charger will not come out of shutdown mode until  $V_{IN}$  rises 60mV above the battery voltage.

#### Manual Shutdown

At any point in the charge cycle, the EMC5042 can be put into shutdown mode by removing  $R_{SET}$  thus floating the ISETA pin. This reduces the battery drain current to about 0uA and the supply current to less than 150uA. A new charge cycle can be initiated by reconnecting the program resistor.

In manual shutdown, the CHG\_SB pin is in a weak pull-down state as long as  $V_{IN}$  is high enough to exceed the UVLO conditions. The CHG\_SB pin is in a high impedance state if the EMC5042 is in under-voltage lockout mode: either  $V_{IN}$  is within 60mV of the BATT pin voltage or insufficient voltage is applied to the IN pin.

#### Automatic Recharge

Once the charge cycle is terminated, the EMC5042 continuously monitors the voltage on the BATT pin using a comparator with a 150us filter time ( $T_{RECHARGE}$ ). A charge cycle restarts when the battery voltage falls below 8.1V (which corresponds to approximately 80% to 90% battery capacity). This ensures that the battery is kept at or near a fully charged condition and eliminates the need for periodic charge cycle initiations. CHG\_SB output enters a strong pull-down state during recharge cycles.

## Application Information

### Stability Considerations

The constant-voltage mode feedback loop is stable without an output capacitor provided a battery is connected to the charger output. With no battery present, an output capacitor is recommended to reduce ripple voltage. When using high value, low ESR ceramic capacitors, it is recommended to add a 1Ω resistor in series with the capacitor. No series resistor is needed if tantalum capacitors are used.

In constant-current mode, the ISETA pin is in the feedback loop, not the battery. The constant-current mode stability is affected by the impedance at the ISETA pin. With no additional capacitance on the ISETA pin, the charger is stable with program resistor values as high as 100k. However, additional capacitance on this node reduces the maximum allowed program resistor. The pole frequency at the ISETA pin should be kept above 100kHz. Therefore, if the ISETA pin is loaded with a capacitance,  $C_{SET}$ , the following equation can be used to calculate the maximum resistance value for  $R_{SET}$ :

$$R_{SET} \leq \frac{1}{2\pi \times 10^5 \times C_{SET}}$$

Average, rather than instantaneous, charge current may be of interest to the user. For example, if a switching power supply operating in low current mode is connected in parallel with the battery, the average current being pulled out of the BATT pin is typically of more interest than the instantaneous current pulses. In such a case, a simple RC filter can be used on the ISETA pin to measure the average battery current as shown in Figure 3. A 10kΩ resistor has been added between the ISETA pin and the filter capacitor to ensure stability.

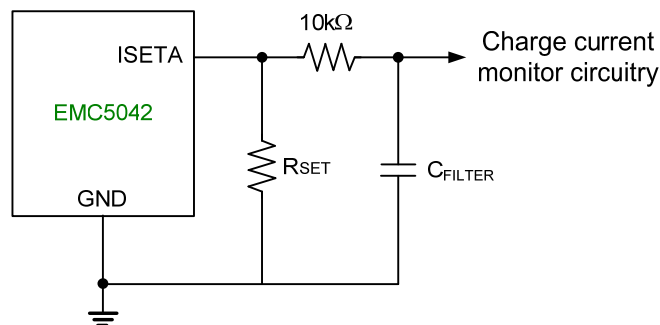

FIG.3 Isolating capacitive load on ISETA pin and filtering

### Power Dissipation

The conditions that cause the EMC5042 to reduce charge current through thermal feedback can be approximated by considering the power dissipated in the IC. Nearly all of this power dissipation is generated by the internal MOSFET, this is calculated to be approximately:

$$P_D = (V_{IN} - V_{BATT}) \cdot I_{BATT}$$

Where  $P_D$  is the power dissipated,  $V_{IN}$  is the input supply voltage,  $V_{BATT}$  is the battery voltage and  $I_{BATT}$  is the charge current. The approximate ambient temperature at which the thermal feedback begins to protect the IC is:

$$T_A = 120^\circ\text{C} - P_D \cdot \theta_{JA}$$

$$T_A = 120^\circ\text{C} - (V_{IN} - V_{BATT}) \cdot I_{BATT} \cdot \theta_{JA}$$

Example:

An EMC5042 operating from a 9V supply is programmed to supply 500mA full-scale current to a discharged Li-Ion battery with a voltage of 7.4V. Assuming  $\theta_{JA}$  is 110°C/W, the ambient temperature at which the EMC5042 will begin to reduce the charge current is approximately:

$$T_A = 120^\circ\text{C} - (9\text{V} - 7.4\text{V}) \cdot (500\text{mA}) \cdot 110^\circ\text{C}/\text{W}$$

$$T_A = 120^\circ\text{C} - 0.8\text{W} \cdot 110^\circ\text{C}/\text{W} = 120^\circ\text{C} - 88^\circ\text{C}$$

$$T_A = 32^\circ\text{C}$$

The EMC5042 can be used above 55°C ambient, but the charge current will be reduced from 500mA. The approximate current at a given ambient temperature can be approximated by:

$$I_{\text{BATT}} = \frac{120^\circ\text{C} - T_A}{(V_{\text{IN}} - V_{\text{BATT}}) \times \theta_{\text{JA}}}$$

Using the previous example with an ambient temperature of 70°C, the charge current will be reduced to approximately:

$$I_{\text{BATT}} = \frac{120^\circ\text{C} - 70^\circ\text{C}}{(9 - 7.4) \bullet 110^\circ\text{C/W}} = \frac{50^\circ\text{C}}{176^\circ\text{C/A}}$$

$$I_{\text{BATT}} = 284\text{mA}$$

Moreover, when thermal feedback reduces the charge current, the voltage at the ISETA pin is also reduced proportionally as discussed in the Operation section. It is important to remember that EMC5042 applications do not need to be designed for worst-case thermal conditions since the IC will automatically reduce power dissipation when the junction temperature reaches approximately 120°C.

### Thermal Considerations

Because of the small size of the TDFN-10 package, it is very important to use a good thermal PC board layout to maximize the available charge current. The thermal path for the heat generated by the IC is from the die to the copper lead frame, through the package leads, (especially the ground lead) to the PC board copper. The PC board copper is the heat sink. The footprint copper pads (thermal land) should be as wide as possible and expand out to larger copper areas to spread and dissipate the heat to the surrounding ambient. Feed-through vias to inner or backside copper layers are also useful in improving the overall thermal performance of the charger. Other heat sources on the board, not related to the charger, must also be considered when designing a PC board layout because they will affect overall temperature rise and the maximum charge current.

### Increasing Thermal Regulation Current

Reducing the voltage drop across the internal MOSFET can significantly decrease the power dissipation in the IC. This has the effect of increasing the current delivered to the battery during thermal regulation. One method is by dissipating some of the power through an external component, such as a resistor or diode.

Example: An EMC5042 operating from a 10V wall adapter is programmed to supply 1A full-scale current to a discharged Li-Ion battery with a voltage of 7.4V. Assuming  $\theta_{\text{JA}}$  is 50°C/W, the approximate charge current at an ambient temperature of 25°C is:

$$I_{\text{BATT}} = \frac{120^\circ\text{C} - 25^\circ\text{C}}{(10\text{V} - 7.4\text{V}) \bullet 50^\circ\text{C/W}} = 730\text{mA}$$

By dropping voltage across a resistor in series with a 10V wall adapter (shown in Figure 4), the on-chip power dissipation can be decreased, thus increasing the thermally regulated charge current

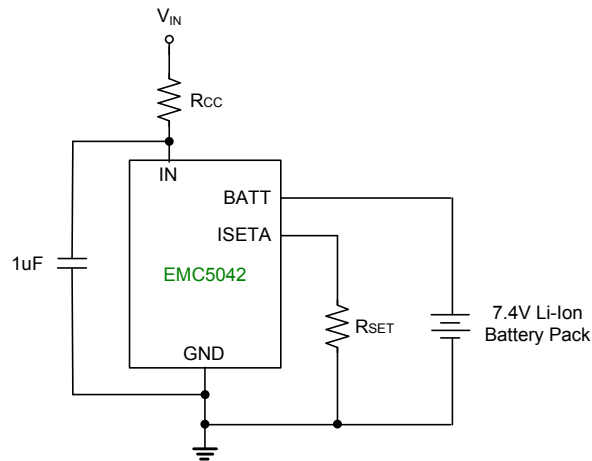

FIG.4 A circuit to maximize charge current

$$I_{BATT} = \frac{120^{\circ}C - 25^{\circ}C}{(V_{IN} - I_{BATT} R_{CC} - V_{BATT}) \bullet \theta_{JA}}$$

Solving for  $I_{BATT}$  using the quadratic formula.

$$I_{BATT} = \frac{1}{2R_{CC}} \left[ (V_{IN} - V_{BATT}) - \sqrt{(V_{IN} - V_{BATT})^2 - \frac{4R_{CC}(120^{\circ}C - T_A)}{\theta_{JA}}} \right]$$

(Note: Large values of  $R_{CC}$  will result in no solution for  $I_{BATT}$ . This indicates that the EMC5042 will not generate enough heat to require thermal regulation.)

Using  $R_{CC} = 0.5\Omega$ ,  $V_{IN} = 10V$ ,  $V_{BATT} = 7.4V$ ,  $T_A = 25^{\circ}C$  and  $\theta_{JA} = 50^{\circ}C/W$  we can calculate the thermally regulated charge current to be:

$$I_{BATT} = 880mA$$

While this application delivers more energy to the battery and reduces charge time in thermal mode, it may actually lengthen charge time in voltage mode if  $V_{IN}$  becomes low enough to put the EMC5042 into dropout.

This technique works best when  $R_{CC}$  values are minimized to keep component size small and avoid dropout. Remember to choose a resistor with adequate power handling capability.

**$V_{IN}$  Bypass Capacitor**

Many types of capacitors can be used for input bypassing, however, caution must be exercised when using multilayer ceramic capacitors. Because of the self-resonant and high Q characteristics of some types of ceramic capacitors, high voltage transients can be generated under some start-up conditions, such as connecting the charger input to a live power source. Adding a  $1.5\Omega$  resistor in series with an X5R ceramic capacitor will minimize start-up voltage transients.

**Charge Current Soft-Start**

The EMC5042 includes a soft-start circuit to minimize the inrush current at the start of a charge cycle. When a charge cycle is initiated, the charge current ramps from zero to the full-scale current over a period of approximately 100us. This has the effect of minimizing the transient current load on the power supply during start-up.

**CHG\_SB Status Output Pin**

The CHG\_SB pin can provide an indication that the input voltage is greater than the under-voltage lockout threshold level. A weak pull-down current of approximately 25uA indicates that sufficient voltage is applied to ACIN to begin charging. When a discharged battery is connected to the charger, the constant current portion of the charge cycle begins and the CHG\_SB pin pulls to ground. The CHG\_SB pin can sink up to 10mA to drive an LED that indicates that a charge cycle is in progress.

When the battery is nearing full charge, the charger enters the constant-voltage portion of the charge cycle and the charge current begins to drop. When the charge current drops below 1/10 of the programmed current, the charge cycle ends and the strong pull-down is replaced by the 25uA pull-down, indicating that the charge cycle has ended. If the input voltage is removed or drops below the under-voltage lockout threshold, the CHG\_SB pin becomes high impedance. Figure 5 shows that by using two different value pull-up resistors, a microprocessor can detect all three states from this pin.

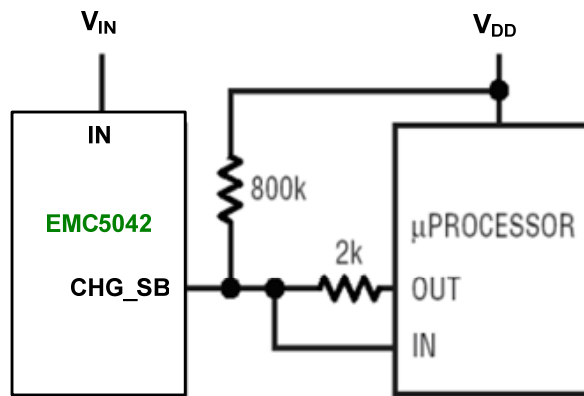

FIG.5 Using a microprocessor to determine CHG\_SB state

To detect when the EMC5042 is in charge mode, force the digital output pin (OUT) high and measure the voltage at the CHG\_SB pin. The internal N-channel MOSFET will pull the pin voltage low even with the 2k pull-up resistor. Once the charge cycle terminates, the N-channel MOSFET is turned off and a 25uA current source is connected to the CHG\_SB pin. The IN pin will then be pulled high by the 2k pull-up resistor. To determine if there is a weak pull-down current, the OUT pin should be forced to a high impedance state. The weak current source will pull the IN pin low through the 800k resistor; if CHG\_SB is high impedance, the IN pin will be pulled high, indicating that the part is in a UVLO state.

**Reverse Polarity Input Voltage Protection**

In some applications, protection from reverse polarity voltage on IN pin is desired. If the supply voltage is high enough, a series blocking diode can be used. In other cases, where the voltage drop must be kept low a P-channel MOSFET can be used (as shown in Figure 6).

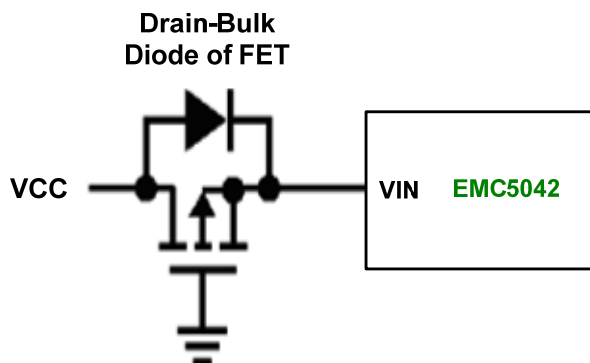

FIG.6 Low loss input reverse polarity protection



### Battery Temperature Monitoring

The EMC5042 continuously monitors battery temperature by measuring the voltage between the TS and GND pins. The EMC5042 has an internal current source to provide the bias for the most common 10kΩ negative-temperature coefficient thermal resistor (NTC) (see Figure 7). The EMC5042 compares the voltage on the TS pin against the internal VTS\_HIGH and VTS\_LOW thresholds to determine if charging is allowed.

When the temperature outside the VTS\_HIGH and VTS\_LOW thresholds is detected, the device will immediately stop the charge. The EMC5042 stops charge and keep monitoring the battery temperature when the temperature sense input voltage is back to the threshold between VTS\_HIGH and VTS\_LOW, the charger will be resumed. Charge is resumed when the temperature returns to the normal range. However the user may modify the thresholds by the negative-temperature coefficient thermal resistor. The capacitor should be placed close to TS pin and connected to the ground plane. The capacitance value (0.1uF to 10uF) should be selected according to the quality of PCB layout.

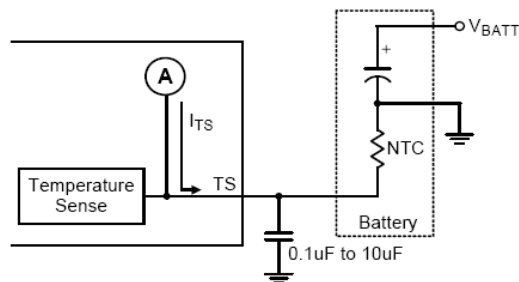

$$V_{TS} = I_{TS} \times R_{NTC}$$

Turn off when  $V_{TS} \geq 2.5V$  or  $V_{TS} \leq 0.5V$

FIG.7 The battery thermal detecting circuit

Package Outline Drawing  
TDFN-10L (3x3 mm)

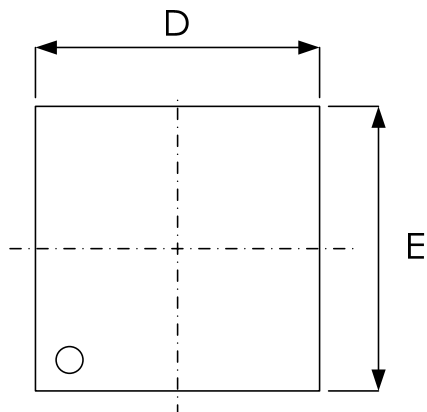

**TOP VIEW**

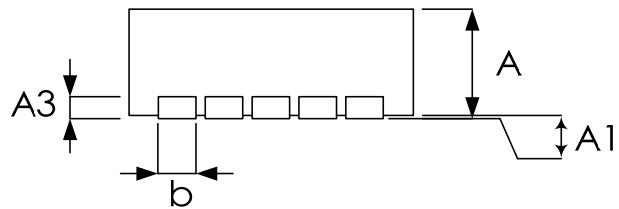

**SIDE VIEW**

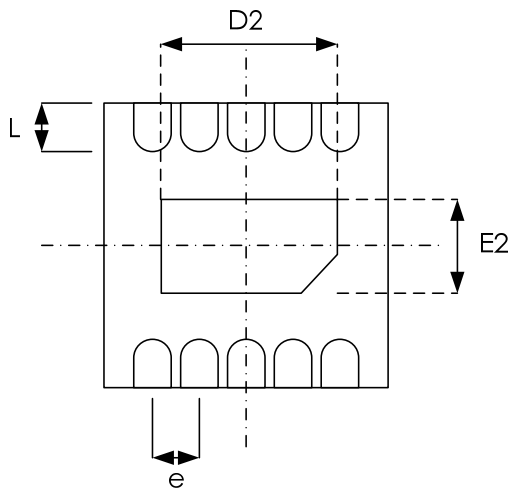

**BOTTOM VIEW**

Symbol	Dimension in mm	
	Min	Max
A	0.70	0.85
A1	0.00	0.05
A3	0.18	0.25
b	0.18	0.30
D	2.95	3.05
E	2.95	3.05
e	0.5 BSC	
L	0.30	0.50

Exposed pad

	Dimension in mm	
	Min	Max
D2	2.20	2.70
E2	1.40	1.75

## Old Order, Marking & Packing Information

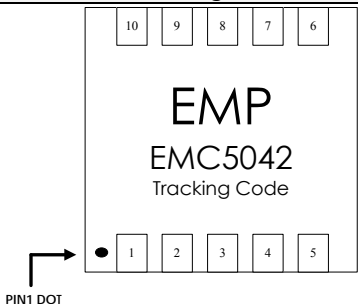
Package	Product ID.	Marking	Packing
<p>TDFN-10 (3x3 mm)</p>	<p>EMC5042-84FF10NRR</p>		<p>Tape &amp; Reel 5Kpcs</p>

## Revision History

Revision	Date	Description
0.1	2011.02.25	Preliminary version
1.0	2011.08.03	Skip "Preliminary"
1.1	2012.07.05	1. Added $V_{RUN}$ operation in electrical characteristics. 2. Updated the package outline drawing.
1.2	2013.10.17	Modify marking

### Important Notice

All rights reserved.

No part of this document may be reproduced or duplicated in any form or by any means without the prior permission of ESMT.

The contents contained in this document are believed to be accurate at the time of publication. ESMT assumes no responsibility for any error in this document, and reserves the right to change the products or specification in this document without notice.

The information contained herein is presented only as a guide or examples for the application of our products. No responsibility is assumed by ESMT for any infringement of patents, copyrights, or other intellectual property rights of third parties which may result from its use. No license, either express, implied or otherwise, is granted under any patents, copyrights or other intellectual property rights of ESMT or others.

Any semiconductor devices may have inherently a certain rate of failure. To minimize risks associated with customer's application, adequate design and operating safeguards against injury, damage, or loss from such failure, should be provided by the customer when making application designs.

ESMT's products are not authorized for use in critical applications such as, but not limited to, life support devices or system, where failure or abnormal operation may directly affect human lives or cause physical injury or property damage. If products described here are to be used for such kinds of application, purchaser must do its own quality assurance testing appropriate to such applications.