

## 2.4W, Mono Class G Audio Power Amplifier with AGC

### DESCRIPTION

The EUA6230 is a mono Class G power amplifier with an integrated inverting charge-pump power supply and automatic gain control (AGC). The charge pump can supply up to 500mA of peak out-put current over a 2.7V to 5V supply voltage range, guaranteeing up to 2.4W output power into an 8Ω load. The AGC function can prevent distortion of the audio signal by detecting output signal clip due to the over level input signal and compressing it automatically.

The EUA6230 offers good performance through the class G output stage, which provides efficiency levels greater than Class AB devices without the EMI penalties commonly associated with Class D amplifiers. The device utilizes fully differential inputs and outputs, comprehensive click-and-pop suppression, shutdown control, and soft-start circuitry. The EUA6230 is available in 28-pin TQFN (4mm×4mm) package.

### FEATURES

- 2.7V-5.0V Operation
- Auto Gain Control for Non-Clipping
- 61% Efficiency ( $V_{CC}=5V$ ,  $P_{OUT}=1W$ )
- 2.4W Output Power into 8Ω at  $V_{CC}=5V$
- Up to 2.4W Instantaneous Output Power into 8Ω
- Integrated Charge-Pump Power Supply
- Click-and-Pop Suppression
- Auto Gain Control for Non-Clipping
- Available in TQFN-28 Package
- RoHS Compliant and 100% Lead(Pb)-Free Halogen-Free

### APPLICATIONS

- Mobile Phones/ Smartphones
- Personal Media Players
- Tablet PC
- Handheld Gaming
- Notebook Computers

### Typical Application Circuit

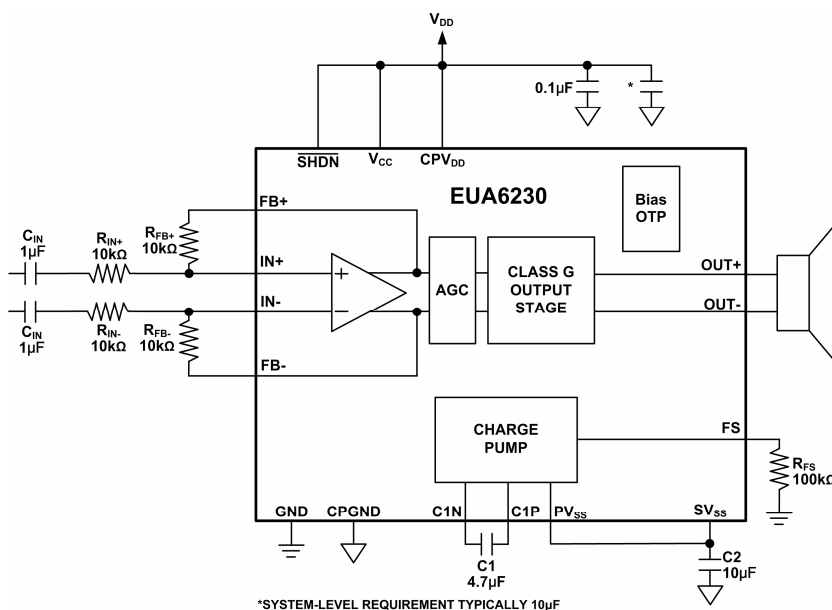

Figure1.

## Pin Configurations

Package Type	Pin Configurations
TQFN-28	<p>(TOP VIEW)</p>

## Pin Description

PIN	TQFN-28	DESCRIPTION
$\overline{\text{SHDN}}$	1	Shutdown. “High Voltage” enable IC, “Low Voltage” disable IC, $\overline{\text{SHDN}}$ pin can not be floating.
NC	2,5,6,8,11,17,19,23,25,28	No Connection. No internal connection.
C1P	3	Charge-Pump Flying Capacitor, Positive Terminal. Connect a 4.7 $\mu\text{F}$ capacitor between C1P and CIN.
CPV <sub>DD</sub>	4	Charge-Pump Positive Supply
FB-	7	Negative Amplifier Feedback
IN-	9	Negative Amplifier Input
IN+	10	Positive Amplifier Input
FB+	12	Positive Amplifier Feedback
FS	13	Charge-Pump Frequency Set. Connect a 100k $\Omega$ resistor from FS to GND to set the charge-pump switching frequency.
V <sub>CC</sub>	14,22	Supply Voltage. Bypass with a 10 $\mu\text{F}$ capacitor to GND.
SV <sub>SS</sub>	15,21	Amplifier Negative Power Supply. Connect to PV <sub>SS</sub> .
OUT-	16	Negative Amplifier Output
GND	18	Ground
OUT+	20	Positive Amplifier Output
PV <sub>SS</sub>	24	Charge-Pump Output. Connect a 10 $\mu\text{F}$ capacitor between PV <sub>SS</sub> and CPGND.
CIN	26	Charge-Pump Flying Capacitor, Negative Terminal. Connect a 4.7 $\mu\text{F}$ capacitor between CIN and C1P.
CPGND	27	Charge-Pump Ground. Connect to GND.

## Ordering Information

Order Number	Package Type	Marking	Operating Temperature Range
EUA6230JIR1	TQFN-28	XXXXX A6230	-40 °C to 85°C

EUA6230 □ □ □ □

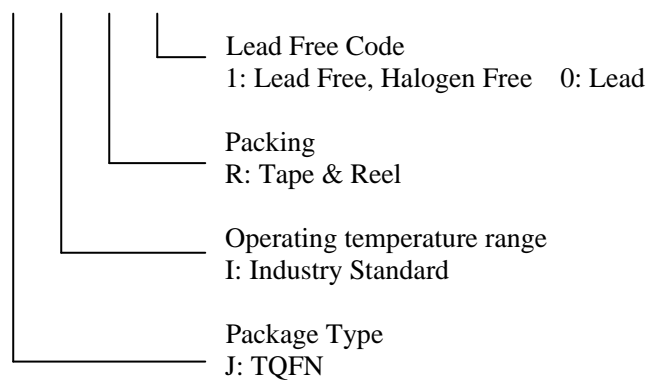

## Simple Block Diagram

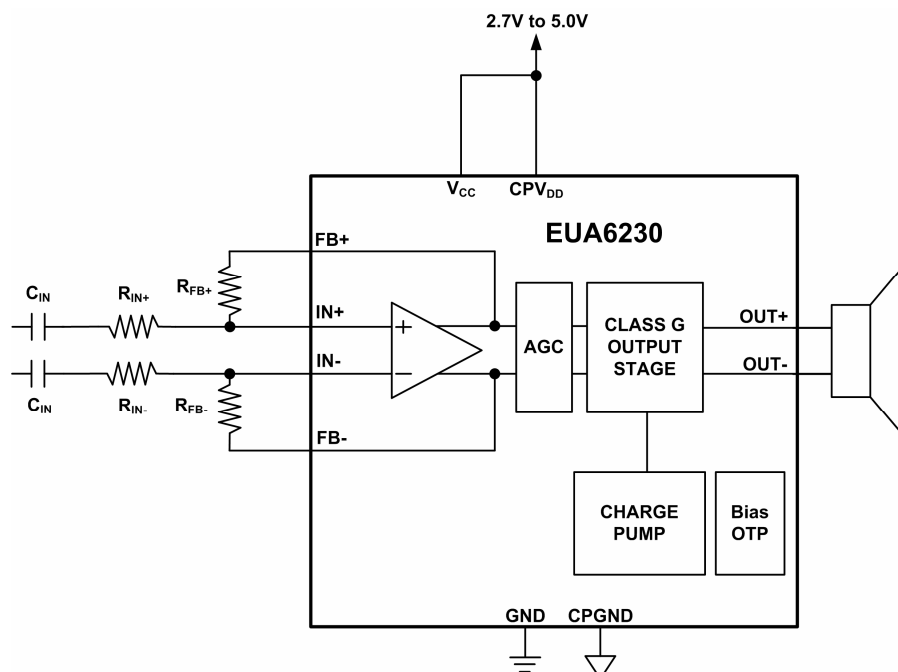

Figure2.

## Absolute Maximum Ratings

▪ $V_{CC}$ , $CPV_{DD}$ -----	-0.3 V to 5.3V
▪ $PV_{SS}$ , $SV_{SS}$ -----	-5.3V to +0.3V
▪ $CPGND$ -----	-0.3V to +0.3V
▪ $OUT+$ , $OUT-$ -----	( $SV_{SS}-0.3V$ ) to ( $V_{CC}+0.3V$ )
▪ $IN+$ , $IN-$ , $FB+$ , $FB-$ -----	-0.3V to ( $V_{CC}+0.3V$ )
▪ $C1N$ -----	( $PV_{SS}-0.3V$ ) to ( $CPGND+0.3V$ )
▪ $C1P$ -----	( $CPGND-0.3V$ ) to ( $CPV_{DD}+0.3V$ )
▪ $FS$ , $\overline{SHDN}$ -----	-0.3V to ( $V_{CC}+0.3V$ )
▪ Storage temperature -----	-65°C to 150°C
▪ Junction Temperature -----	150°C
▪ Lead Temperature (soldering, 10s) -----	260°C
▪ Thermal Resistance	
$\theta_{JA}$ (TQFN-28) -----	40°C/W

## Electrical Characteristics

( $V_{CC}=CPV_{DD}=\overline{SHDN}=3.6V$ ,  $GND=CPGND=0V$ ,  $R_{IN+}=R_{IN-}=10k\Omega$ ,  $R_{FS}=100k\Omega$ ,  $C1=4.7\mu F$ ,  $C2=10\mu F$ ; speaker load resistors ( $R_L$ ) are terminated between  $OUT+$  and  $OUT-$ , unless otherwise stated;  $T_A=T_{MIN}$  to  $T_{MAX}$ , unless otherwise noted. Typical values are at  $T_A=25^\circ C$ .) (Notes 1,2)

Symbol	Parameter	Conditions	EUA6230			Unit
			Min.	Typ.	Max.	
<b>GENERAL</b>						
$V_{CC}$	Supply Voltage Range	Inferred from PSRR test	2.7		5	V
$I_{CC}$	Quiescent Current			4.6	12	mA
$P_{DISS}$	Chip Power Dissipation	$V_{OUT}=2.8V_{RMS}$ , $f=1kHz$ , $R_L=8\Omega$		1.3		W
$I_{\overline{SHDN}}$	Shutdown Current	$\overline{SHDN}=GND$		0.1	5	$\mu A$
$t_{ON}$	Turn-On Time	Time from shutdown or power-on to full operation		55		ms
$V_{BIAS}$	Input DC Bias Voltage	$IN\_inputs$	1.1	1.24	1.4	V
$f_{OSC}$	Charge-Pump Oscillator Frequency (Slow Mode)	$I_{LOAD}=0mA$ (slow mode)	55	83	110	kHz
		$I_{LOAD}>100mA$ (normal mode)	230	330	430	
$C_L$	Maximum Capacitive Load			200		pF
	$\overline{SHDN}$ Input Threshold	$V_{IH}$	1.4			V
		$V_{IL}$			0.4	
	$\overline{SHDN}$ Input Leakage Current				1	$\mu A$
<b>SPEAKER AMPLIFIER</b>						
$V_{OS}$	Output Offset Voltage	$T_A=25^\circ C$		$\pm 3$	$\pm 40$	mV
$A_V$	Voltage Gain		11.5	12	12.5	dB
$P_{OUT}$	Continuous Output Power	THD+N=1%, $f=1kHz$ , $R_L=8\Omega$	$V_{CC}=5V$		2.4	W
			$V_{CC}=4.2V$		1.67	
			$V_{CC}=3.6V$		1.25	
			$V_{CC}=3.0V$		0.8	

## Electrical Characteristics (continued)

( $V_{CC}=CPV_{DD}=\overline{SHDN}=3.6V$ ,  $GND=CPGND=0V$ ,  $R_{IN+}=R_{IN-}=10k\Omega$ ,  $R_{FS}=100k\Omega$ ,  $C1=4.7\mu F$ ,  $C2=10\mu F$ ; speaker load resistors ( $R_L$ ) are terminated between  $OUT+$  and  $OUT-$ , unless otherwise stated;  $T_A=T_{MIN}$  to  $T_{MAX}$ , unless otherwise noted. Typical values are at  $T_A=25^\circ C$ .) (Notes 1,2)

Symbol	Parameter	Conditions	EUA6230			Unit
			Min.	Typ.	Max.	
<b>SPEAKER AMPLIFIER</b>						
PSRR	Power-Supply Rejection Ratio	$V_{CC}=2.7V$ to $5.0V$		69		dB
		$f=217Hz$ , $200mV_{P-P}$ ripple		64		
		$f=1kHz$ , $200mV_{P-P}$ ripple		60		
THD+N	Total Harmonic Distortion Plus Noise	$R_L=8\Omega$ , $V_{OUT}=1kHz/400mW$		0.01		%
		$R_L=8\Omega$ , $V_{OUT}=1kHz/1W$		0.09		
SNR	Signal-to-Noise Ratio	$V_{OUT}=0.5W$ , inputs to GND by C1N A-Weighted		89		dB
Noise	Output Noise	22Hz to 22kHz		102		$\mu V_{rms}$
		A-weighted		71.7		

Note 1: All devices are 100% production tested at room temperature. All temperature limits are guaranteed by design.

Note 2: Testing performed with resistive and inductive loads to simulate an actual speaker load. For dynamic speakers,

$R_L=8\Omega$ ,  $68\mu H$ .

## Typical Operating Characteristics

Total Harmonic Distortion Plus Noise vs. Frequency

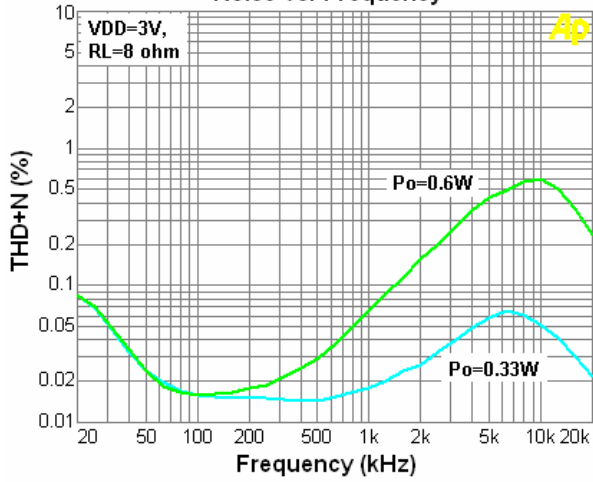

Figure3.

Total Harmonic Distortion Plus Noise vs. Frequency

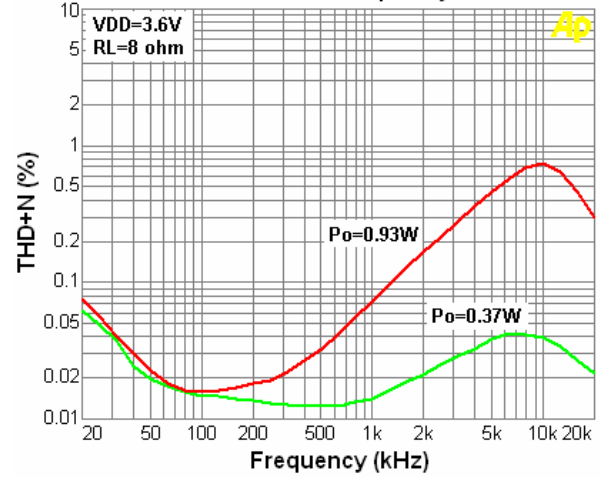

Figure4.

Total Harmonic Distortion Plus Noise vs. Frequency

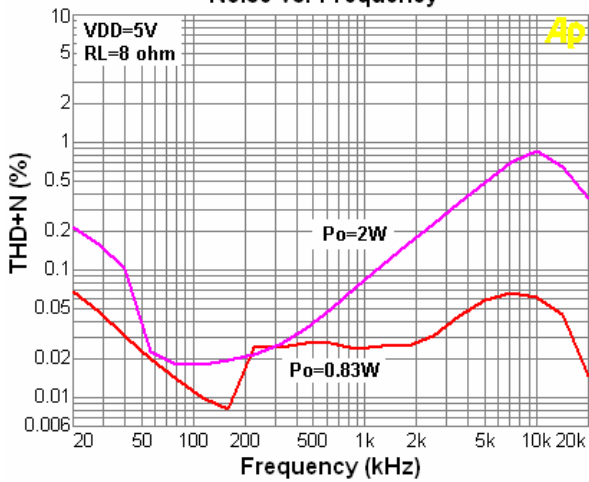

Figure5.

EUA6230 Non-Clipping Function

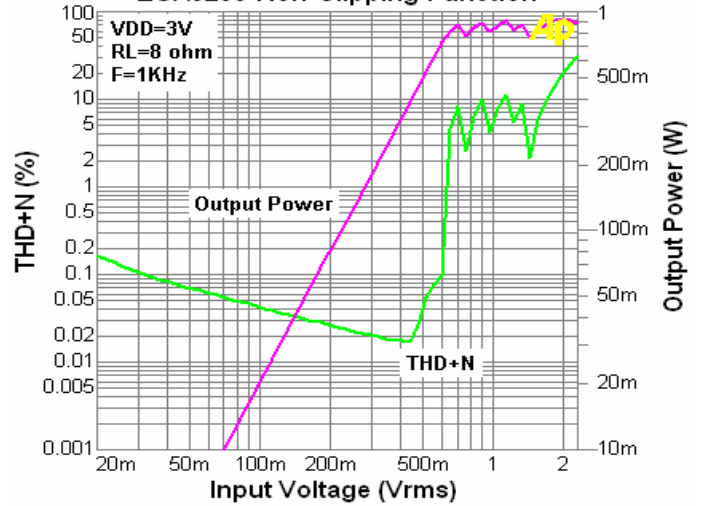

Figure6.

EUA6230 Non-Clipping Function

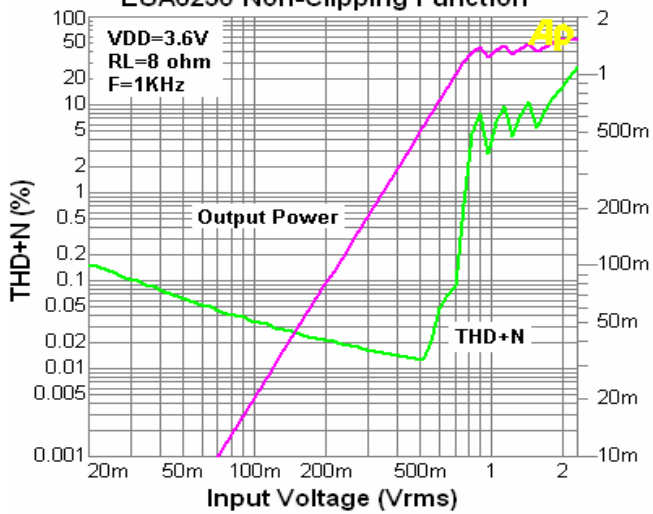

Figure7.

EUA6230 Non-Clipping Function

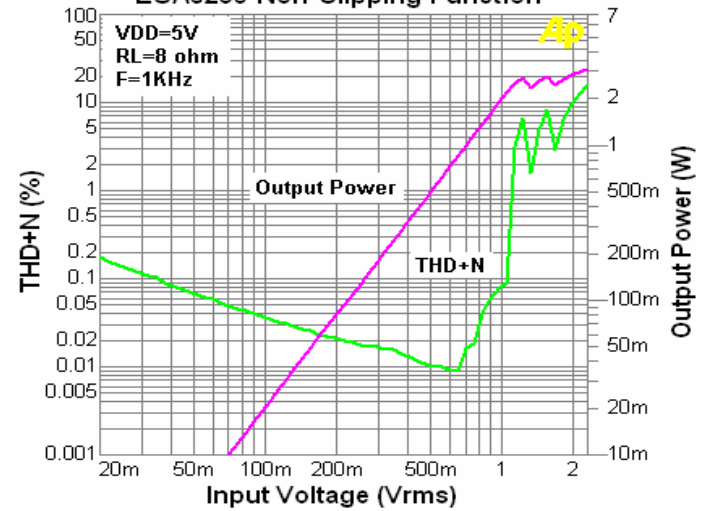
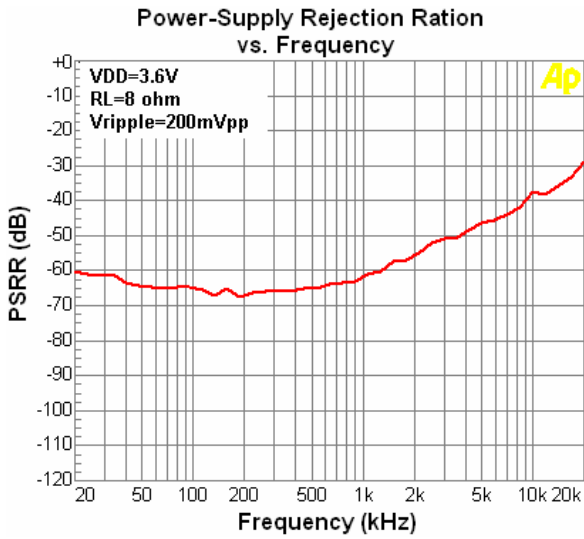
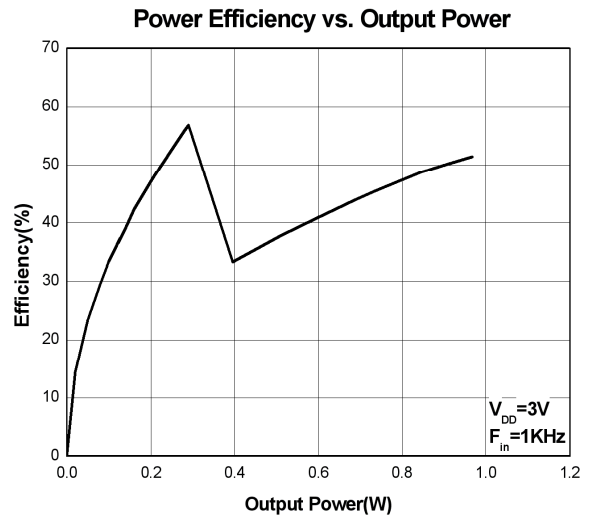

Figure8.

**Typical Operating Characteristics (continued)**



**Figure9.**



**Figure10.**

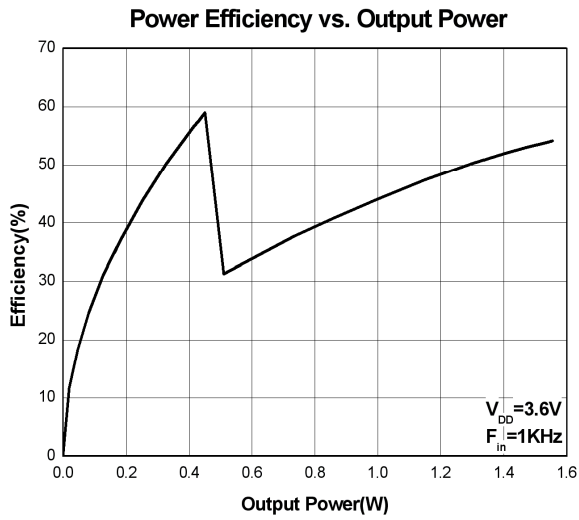

**Figure11.**

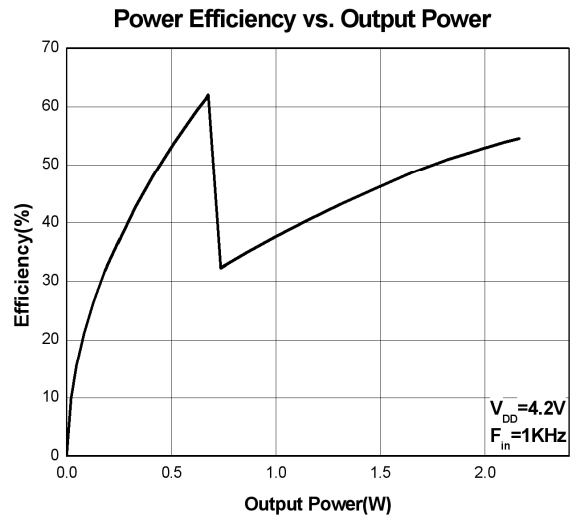

**Figure12.**

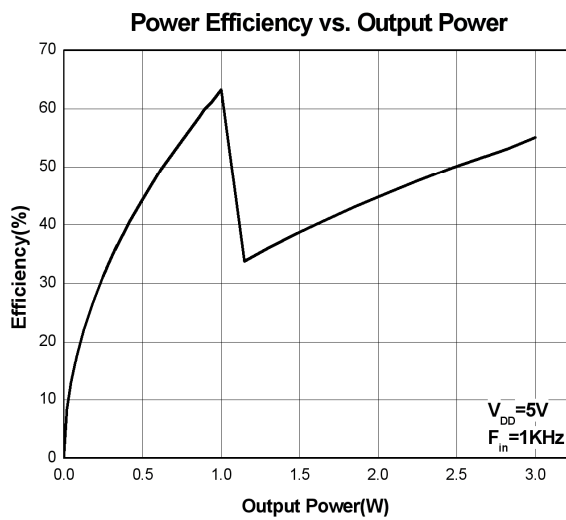

**Figure13.**

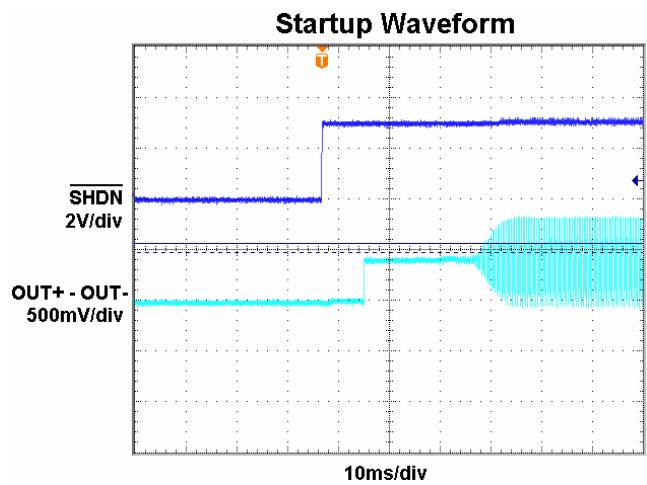

**Figure14.**

**Typical Operating Characteristics (continued)**

**Shutdown Waveform**

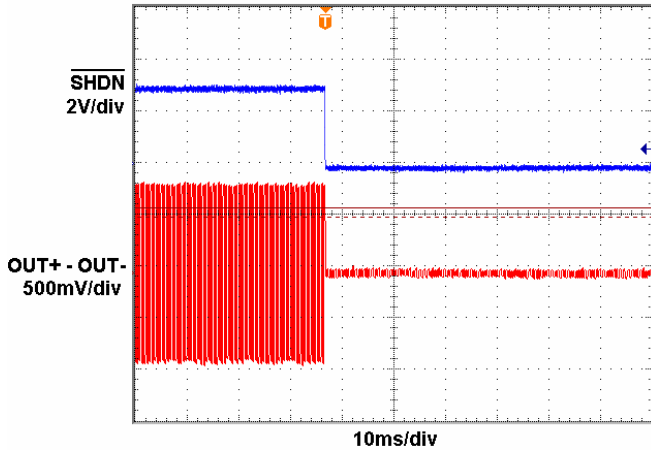

**Figure15.**

**Supply Current vs. Supply Voltage**

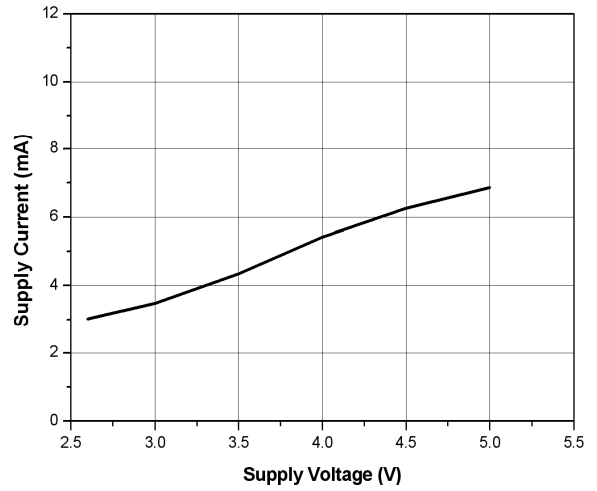

**Figure16.**

**Shutdown Current vs. Supply Voltage**

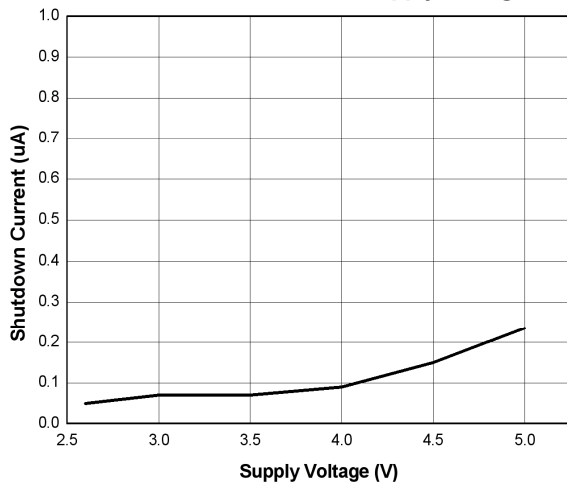

**Figure17.**

**Output Power vs. Supply Voltage**

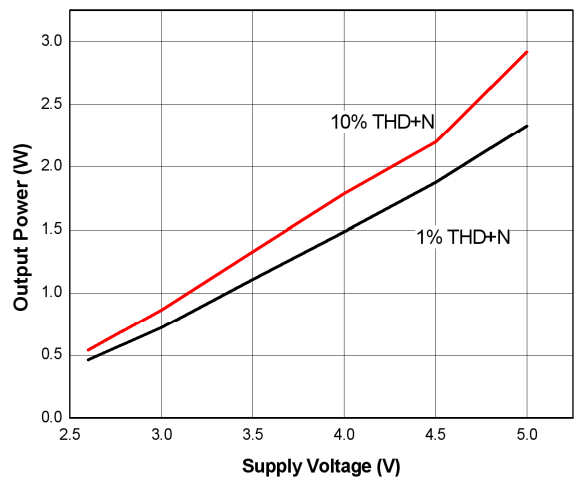

**Figure18.**

**Class G Output Waveform**

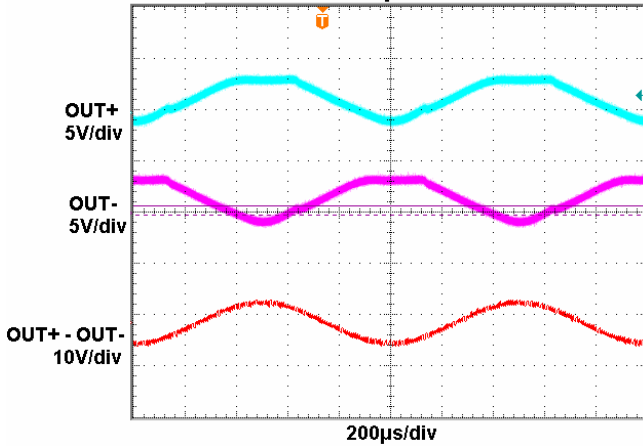

**Figure19.**

**Frequency Response**

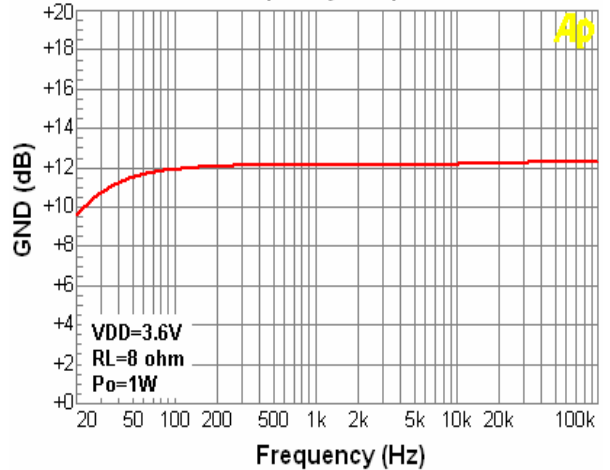

**Figure20.**



**Typical Operating Characteristics (continued)**

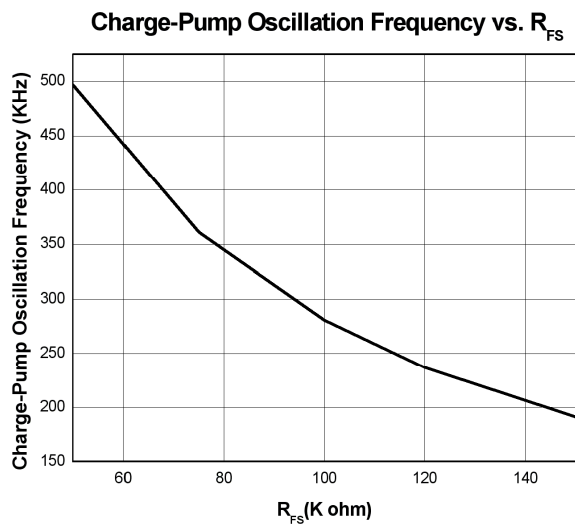

**Figure21.**

## Detail Description

The EUA6230 Class G power amplifier with inverting charge pump is the latest in linear amplifier technology. The Class G output stage offers the performance of a Class AB amplifier while increasing efficiency to extend battery life. The integrated inverting charge pump generates a negative supply capable of delivering up to 500mA.

The Class G output stage and the inverting charge pump allow the EUA6230 to deliver an output power that is up to four times greater than a traditional single-supply linear amplifier. This allows the EUA6230 to maintain 0.8W into an 8Ω load as the battery rail collapses.

### Class G Operation and Efficiency

The EUA6230 Class G amplifier is a linear amplifier that operates within a low ( $V_{CC}$  to GND) and high ( $V_{CC}$  to  $SV_{SS}$ ) supply range.

During operation, the output common-mode voltage of the EUA6230 adjusts dynamically as the device transitions between supply ranges.

Utilizing a Class G output stage with an inverting charge pump allows the EUA6230 to realize a 2.4W output power with a 5V supply.

The theoretical best efficiency of a linear amplifier is 78%; however, that efficiency is only exhibited at peak output powers. Under normal operating levels (typical music reproduction levels), efficiency falls, where as the EUA6230 still exhibits high efficiency under the same conditions.

### Inverting Charge Pump

The EUA6230 features an integrated charge pump with an inverted supply rail that can supply greater than 700mA over the positive 2.7V to 5V supply range. In the case of the EUA6230, the charge pump generates the negative supply rail (PVSS) needed to create the higher supply range, which allows the output of the device to operate over a greater dynamic range as the battery supply collapses over time.

### Shutdown Mode

The EUA6230 has a shutdown mode that reduces power consumption and extends battery life. Driving  $\overline{SHDN}$  low places the EUA6230 in a low-power (0.3μA) shutdown mode. Connect  $\overline{SHDN}$  to VCC for normal operation.  $\overline{SHDN}$  pin can't be floating.

### Click-and-Pop Suppression

During startup and shutdown, the click-and-pop suppression circuitry eliminates audible pop noise to the output.

### Auto Gain Control Function

The AGC works by detecting the audio input envelope. The gain changes depending on the amplitude, the power supply level, and the attack and release time. The gain

changes constantly as the audio signal increases and/or decreases to suppress the clipped output signal. The gain step size for the AGC is 2dB. The maximum attenuation is -12dB. The attack time is 18ms and the released time is 1.12Sec per step according to 100kΩ  $R_{FS}$ .

## Application Information

### Differential Input Amplifier

The EUA6230 features a differential input configuration, making the device compatible with many CODECs, and offering improved noise immunity over a single-ended input amplifier. In devices such as PCs, noisy digital signals can be picked up by the amplifier's input traces. The signals appear at the amplifiers' inputs as common-mode noise. A differential input amplifier amplifies the difference of the two inputs, and signals common to both inputs are canceled out. When configured for differential inputs, the voltage gain of the EUA6230 is set by:

$$A_V = 20 \log \left[ 4 \times \left( \frac{R_{FB-}}{R_{IN-}} \right) \right] (\text{dB})$$

where  $A_V$  is the desired voltage gain in dB.  $R_{IN+}$  should be equal to  $R_{IN-}$  and  $R_{FB+}$  should be equal to  $R_{FB-}$ . The Class G output stage has a fixed gain of 4V/V (12dB). Any gain or attenuation set by the external input stage resistors will add to or subtract from this fixed gain. See Figure 22.

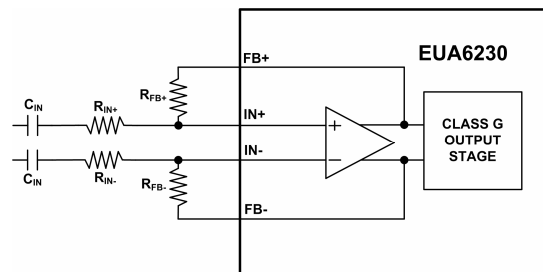

Figure.22

In differential input configurations, the common-mode rejection ratio (CMRR) is primarily limited by the external resistor and capacitor matching. Ideally, to achieve the highest possible CMRR, the following external components should be selected where:

$$\frac{R_{FB+}}{R_{IN+}} = \frac{R_{FB-}}{R_{IN-}}$$

and

$$C_{IN+} = C_{IN-}$$

## Component Selection

### Input-Coupling Capacitor

The AC-coupling capacitors ( $C_{IN\_}$ ) and input resistors ( $R_{IN\_}$ ) form high pass filters that remove any DC bias from an input signal (see the Typical Application Circuit/Functional Diagram).  $C_{IN\_}$  blocks DC voltages from the amplifier. The -3dB point of the high pass filter, assuming zero source impedance due to the input signal source, is given by:

$$f_{-3dB} = \frac{1}{2\pi \times R_{IN\_} \times C_{IN\_}} \text{ (Hz)}$$

Choose  $C_{IN}$  so that  $f_{-3dB}$  is well below the lowest frequency of interest. Setting  $f_{-3dB}$  too high affects the amplifier's low frequency response. Use capacitors with low-voltage coefficient dielectrics. Aluminum electrolytic, tantalum, or film dielectric capacitors are good choices for AC-coupling capacitors. Capacitors with high-voltage coefficients, such as ceramics, can result in increased distortion at low frequencies.

### Charge-Pump Capacitor Selection

Use capacitors with an ESR less than 50m $\Omega$  for optimum performance. Low-ESR ceramic capacitors minimize the output resistance of the charge pump. For best performance over the extended temperature range, select capacitors with an X7R dielectric.

### Flying Capacitor (C1)

The value of the flying capacitor (C1) affects the load regulation and output resistance of the charge pump. A C1 value that is too small degrades the device's ability to provide sufficient current drive. Increasing the value of C1 improves load regulation and reduces the charge-pump output resistance to an extent. Above 1 $\mu$ F, the on-resistance of the switches and the ESR of C1 and C2 dominate. A 4.7 $\mu$ F capacitor is recommended.

### Hold Capacitor (C2)

The output capacitor value and ESR directly affect the ripple at PVSS. Increasing C2 reduces output ripple. Likewise, decreasing the ESR of C2 reduces both ripple and output resistance. A 10 $\mu$ F capacitor is recommended.

### Charge-Pump Frequency Set Resistor ( $R_{FS}$ )

The charge pump operates in two modes. When the charge pump is loaded below 100mA, it operates in as low mode where the oscillation frequency is reduced to 1/4 of its normal operating frequency. Once loaded, the charge-pump oscillation frequency returns to normal operation. In applications where the design may be sensitive to the operating charge-pump oscillation frequency, the value of the external resistor  $R_{FS}$  can be changed to adjust the charge-pump oscillation frequency.

## Thermal Considerations

Class G amplifiers provide much better efficiency and thermal performance than a comparable Class AB amplifier. However, the system's thermal performance must be considered with realistic expectations and include consideration of many parameters. This section examines Class G amplifiers using general examples to illustrate good design practices.

**Packaging Information**

**TQFN-28**

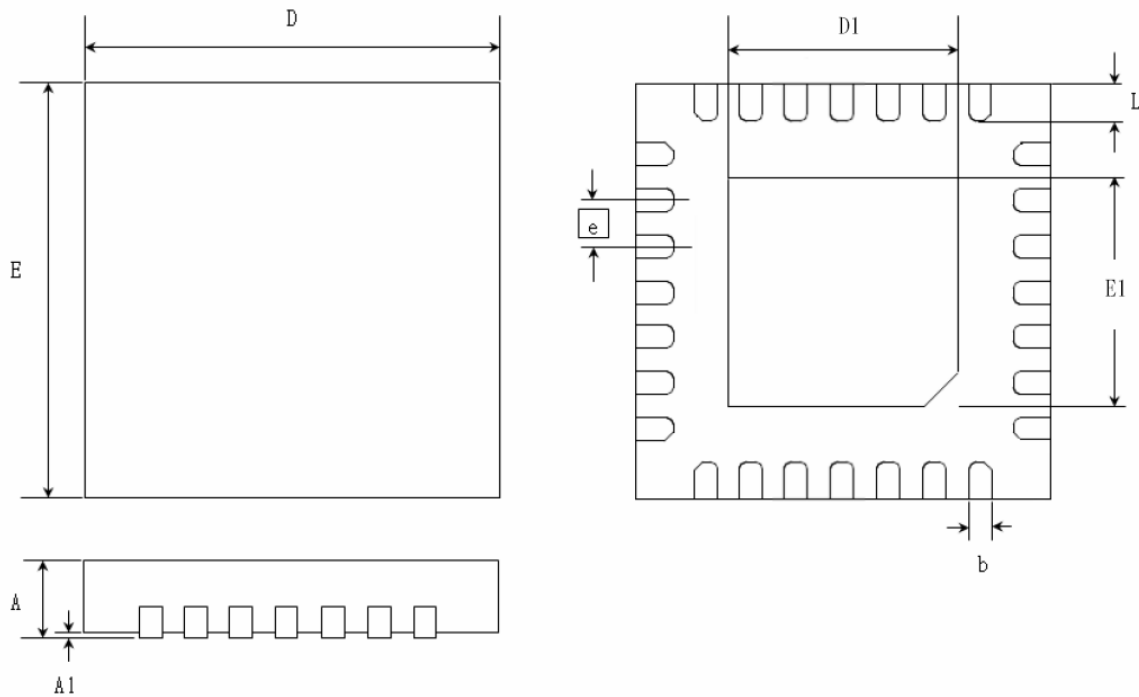

SYMBOLS	MILLIMETERS		INCHES	
	MIN.	MAX.	MIN.	MAX.
A	0.70	0.80	0.028	0.031
A1	0.00	0.05	0.000	0.002
b	0.15	0.25	0.006	0.010
E	3.90	4.10	0.154	0.162
D	3.90	4.10	0.154	0.162
D1	1.90	2.65	0.075	0.104
E1	1.90	2.65	0.075	0.104
e	0.40 BSC		0.016 BSC	
L	0.30	0.50	0.012	0.020