

12V 3-Phase Sensorless Fan Motor

DESCRIPTION

EUM6858R/S is motor driver IC for driving a three-phase brushless DC motor without a hall sensor. It is controlled by a variable speed provided through the PWM input signal, and integrates PWM speed control, soft switching, lock protection, over-voltage protection, fan tachometer, under voltage lock out circuit and forward/reverse functions. The motor downsizing can be achieved by limiting the number of external components as much as possible.

As the application of three-phase driving method, PWM method to control the speed of the fan through the pulse width modulation signal to adjust the duty cycle. Internal soft switching function drives fan motor in low noise and low vibration ways. EUM6858R/S can drive motor from stop mode to rotation mode by adjusting the external capacitor between OSC pin and GND. If a motor is stalled by external force or obstacles, over drive current may incur coil overheat and burning. In order to prevent motor from overheating, the lock protection circuit shuts down the internal power devices for a few seconds after the motor lock is detected. Then the auto restart circuit resumes to power up the internal power devices. If the lock is still continuing, EUM6858R/S shuts down power devices for another few seconds. The lock protection time is built-in and need no external components. During rotation, FG/ 1/2FG outputs motor speed feedback signal. The motor rotation direction can be changed by setting FR to high or low.

Application Circuit

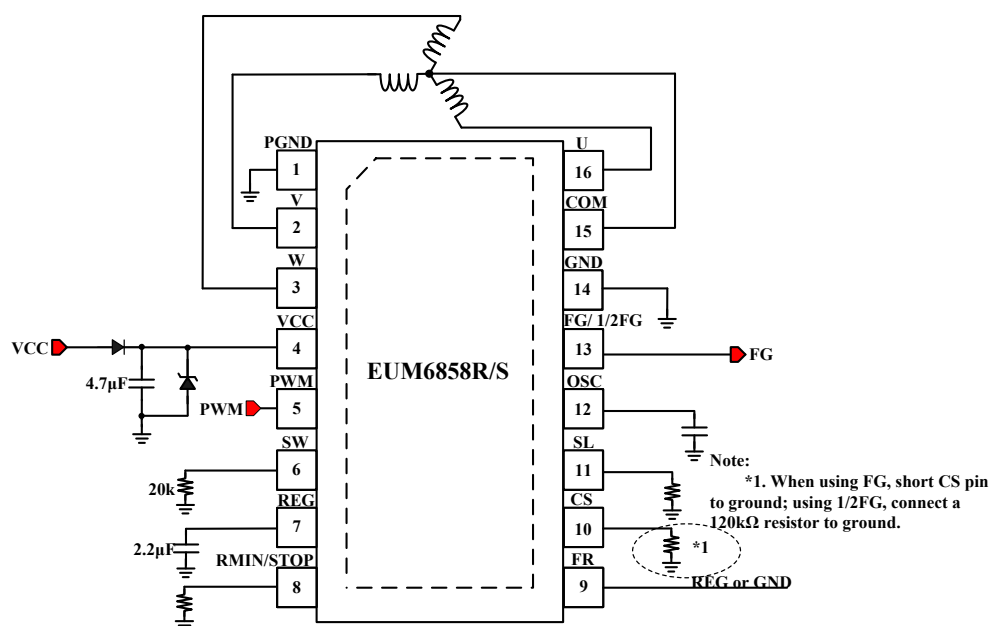

Figure 1. Typical Application Circuit

FEATURES

- 3-Phase Sensorless Drive (No Hall Sensor Needed)
- Wide Input Range 3.0V~20V
- 180° Sinusoidal drive
- Fan Speed Slope Control
- FG and 1/2FG Output
- Few External Components
- Direct PWM Fan Speed Control
- Programmable Minimum Fan Speed (EUM6858R Only)
- Stop Mode PWM Duty Adjustable (EUM6858S Only)
- Lock Protection and Auto Restart
- Fan Rotation Speed Feedback Output
- Available in TSSOP-16 (EP) Package
- RoHS Compliant and 100% Lead (Pb)-Free Halogen-Free

APPLICATIONS

- Low Noise Fan and Low Power Consumption Fan