

6A, 30V, Synchronous Step-Down Converter with Programmable Frequency

DESCRIPTION

The EUP3286 is a synchronous, step-down constant on-time buck regulator capable of driving 6A continuous load current. The EUP3286 can operate with an input range 4.5V to 30V and the output can be externally set down to 0.8V. The EUP3286 provides excellent transient response with constant on-time control method while maintaining a nearly constant frequency. The switching frequency can be externally programmed from 100KHz to 1MHz.

Fault condition protection includes VIN under-voltage lockout, cycle-by-cycle current limiting, output over-voltage protection, short-circuit protection, as well as thermal shutdown. Programmable soft-start minimizes the inrush supply current and the output overshoot at initial startup.

The EUP3286 is available in a 4mm x 4mm TQFN-23 package.

FEATURES

- Wide Input Voltage Range: 4.5V to 30V
- 6A Output Current
- Excellent Line and Load Transient Responses
- Integrated 30mΩ N-Channel MOSFET for High Side
- Integrated 15mΩ N-Channel MOSFET for Low Side
- Programmable PWM Frequency from 100KHz to 1MHz
- Adjustable Soft-Start
- Selectable Forced PWM or Automatic PFM/PWM Mode
- Power Good Monitoring
- Under-Voltage Protection
- Over-Voltage Protection
- Cycle-by-Cycle Current Limit
- Short-Circuit Protection
- Over-Temperature Protection
- Available in TQFN-23 4mmx4mm Package
- RoHS Compliant and 100% Lead(Pb)- Free, Halogen-Free

APPLICATIONS

- Notebook
- Mother Board
- Table PC
- Hand-Held Portable
- AIO PC
- Set-top boxes
- LCD TV
- Telecom/Networking/Datacom equipment

Typical Application Circuit

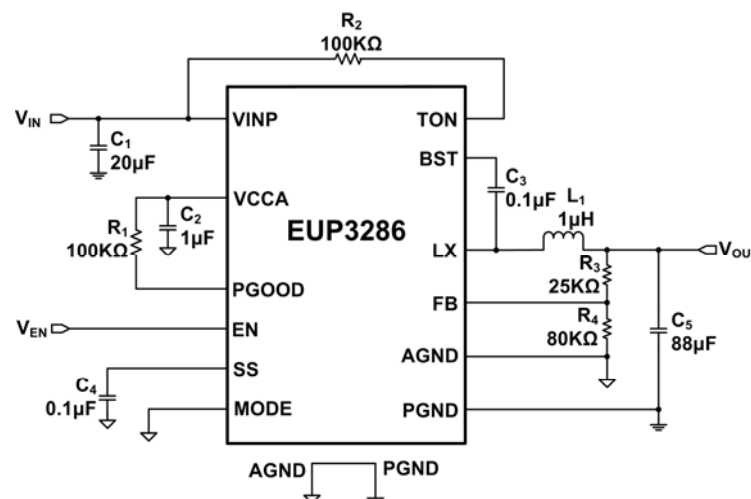

Figure 1. Application Circuit