

Smart motor driver with embedded Hall sensor

FEATURES

- Motor driver with integrated Hall sensor
- High current driving capability
- Lock-shutdown protection & auto-restart function
- Built-in RD(Rotation Detect) signal output
- Precise magnetic switching thresholds
- “Soft-switch” phase-switching technique to reduce vibration and acoustic noise(patent pending)
- Thermal shutdown protection
- PWM speed control(only available for FD0256b)
- Available in both T825(FD0252b) and T826(FD0256b) packages



GENERAL DESCRIPTION

FD0252b/FD0256b is a single coil motor driver with embedded Hall sensor. It integrates the motor driver with the Hall sensor, which simplifies the PCB(printed circuit board) design and make the fabrication of small-size motors possible.

Lock-shutdown and auto-restart function keeps the motor from being over-heated and restarts the motor after being locked.

“Soft-switch” phase-switching technique is used to reduce the vibration and acoustic noise.

Thermal-shutdown protection ensures the motor driver to operate under specified temperature ranges.

All the protection mechanisms mentioned above combine to provide a complete protecting scenario for the motor system, keep the motor system from possible damages and guarantee correct operations.

BLOCK DIAGRAM

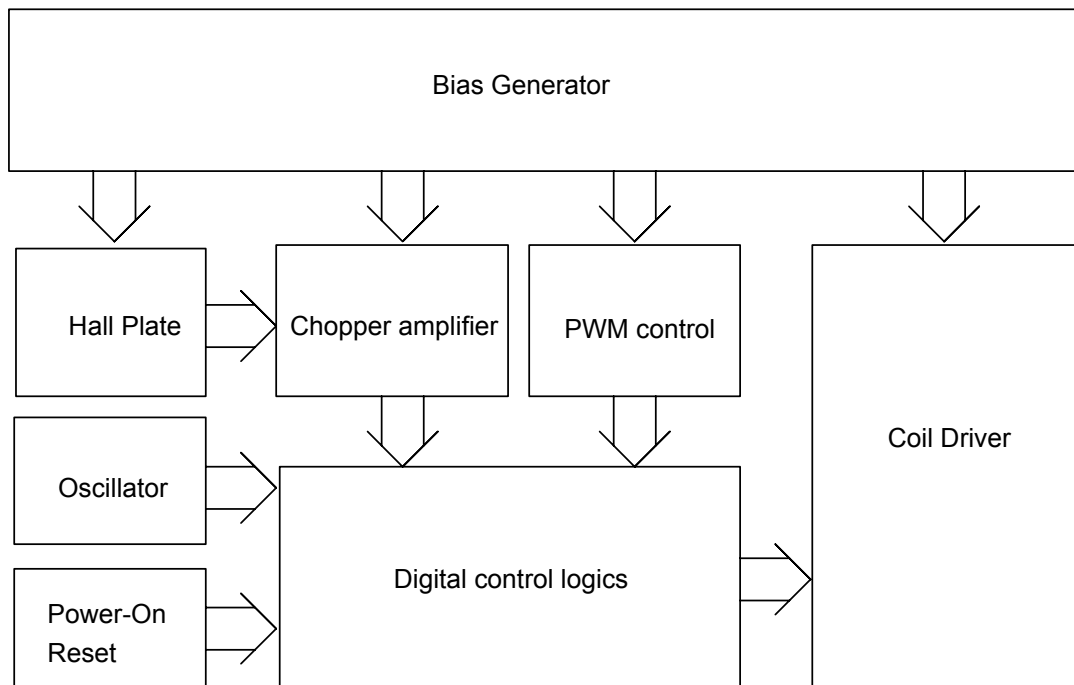
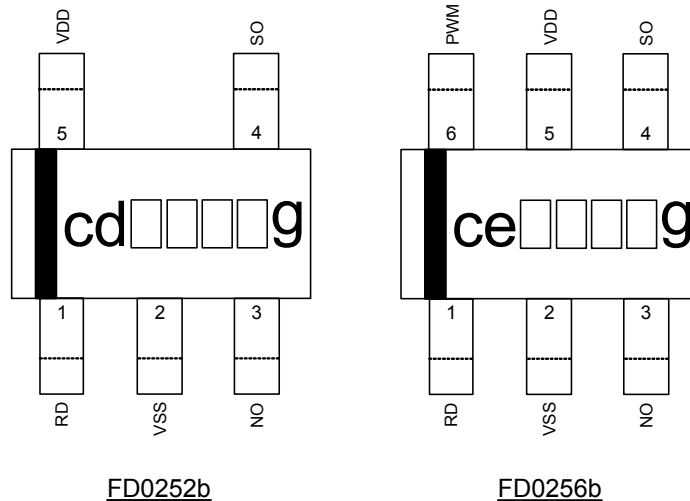

Figure.1

PIN CONNECTION

Figure.2
PIN DESCRIPTIONS

Name	I/O	FD0252b	FD0256b	Description
RD	O	1	1	Rotation Detect
VSS	G	2	2	Ground
NO	O	3	3	Driver output
SO	O	4	4	Driver output
VDD	P	5	5	Positive power supply
PWM	I	-	6	Pulse Width Modulation speed control

Legend: I=input, O=output, I/O=input/output, P=power supply, G=ground

FUNCTIONAL DESCRIPTIONS

Refer to the block diagram (Figure.1), FD0252b/FD0256b is composed of the following building blocks:

- Bias generator

The bias generator provides precise, temperature- and process-insensitive bias references for the analog blocks. These references guarantee proper operation of the IC under all conditions specified in this specification.

- Oscillator

The built-in oscillator provides the clock signal for the digital control logics

- Power-on Reset

Used to detect the power-up ramp and reset the digital circuits to achieve correct operation as soon as the power is ready.

- Chopper Amplifier

To achieve a higher magnetic sensitivity the chopper amplifier structure is adopted in this design. Use of this structure dynamically removes both the offset and flicker noise at the same time.

- Digital control logics

- Hall sensor part – generates controlling signals for the Hall sensor.
- Coil driver part – generates controlling signals for the Coil driver.



- PWM control

PWM(pulse-width modulation) is used for the speed control for FD0256b. 2 types of PWM input signals can be used :

1. Voltage mode PWM :

Applying a constant(DC) voltage to the PWM pin and the FD0256b will generate PWM pulses internally with the "ON" duty cycle ratio according to the diagram below(Figure.3), which can be utilized by the user to control the speed of the motor. The rotation speed will be higher if the voltage applied to the PWM pin is higher.

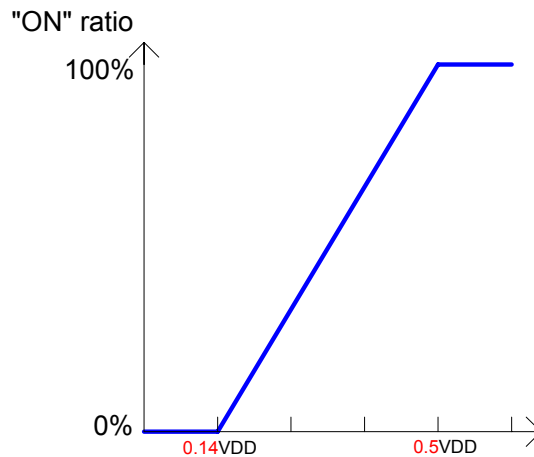

Figure.3

2. Pulse mode PWM :

User can also apply PWM pulses directly to the PWM pin. The FD0256b will pass this pulse to the coil driver with the original duty-cycle ratio.

Note:

- (1) This function is only available for FD0256b
- (2) While using pulse mode PWM, the "High" Value of the input pulse should be higher than $0.5 \cdot VDD$ and the "Low" value should be lower than $0.14 \cdot VDD$
- (3) The lower-limit for the PWM pulse frequency is 200Hz, and the recommended frequency range is higher than 30KHz where the PWM input pulses will not generate acoustic noise.

Note. The "PWM" pin contains an internal pull-up resistor so the FD0256b will rotate at full-speed(100% ON) when this pin is left un-connected(floating).

ABSOLUTE MAXIMUM RATINGS

Parameter	Conditions	Values		Unit
		min.	max.	
Ambient Operating Temperature	-	-20	105	°C
Storage Temperature	-	-40	150	°C
DC Supply Voltage	-	1.8	6.5	V
Supply Current	-		3	mA
Continuous Current			500	mA
Hold current			800	mA
Junction temperature			150	°C
Lead Temperature	10sec		260	°C

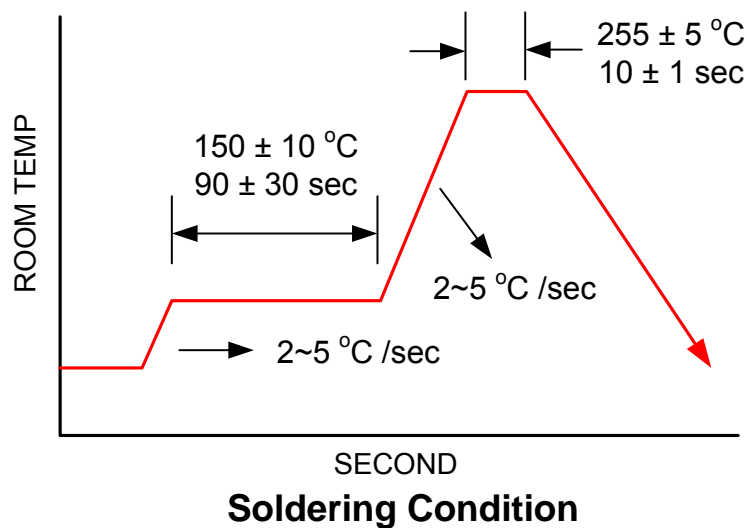
Figure.4

OPERATING CONDITIONS

Parameter	Conditions	Values			Unit
		min.	typ.	max.	
Supply Voltage	-	1.8		6.5	V
Ambient Temperature	-	-20		105	°C

ELECTRICAL CHARACTERISTICS @ VDD=5.0V

Parameter	Conditions	Values			Unit
		min.	typ.	max.	
Average Supply Current(no load)			1.8		mA
Output Saturation Voltage(RD)	I _{out} = 10mA			0.5	V
Output leakage current(RD)	V _{out} =5V			1	uA
On resistance(R _{pmos} +R _{nmos})			1.6		Ohm
Thermal Shutdown Threshold			165		°C

MAGNETIC CHARACTERISTICS

Parameter	Conditions	Values			Unit
		min.	typ.	max.	
Operate Points (B _{OP})			25		G
Release Points (B _{RP})			-25		G
Hysteresis			50		G

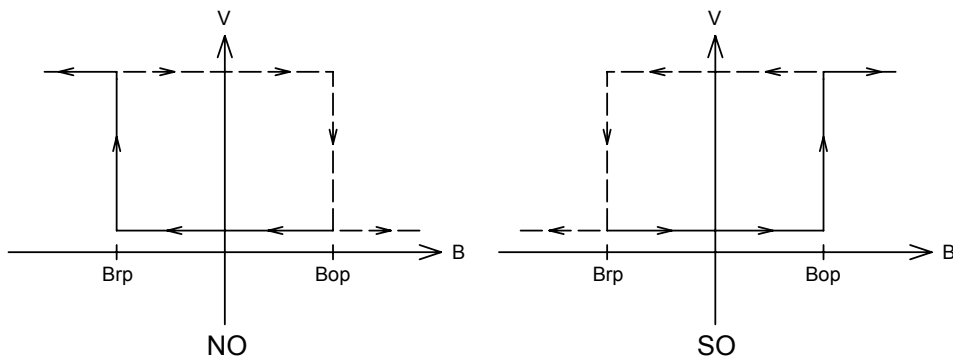
HYSTERESIS CHARACTERISTICS



Application Circuit Reference

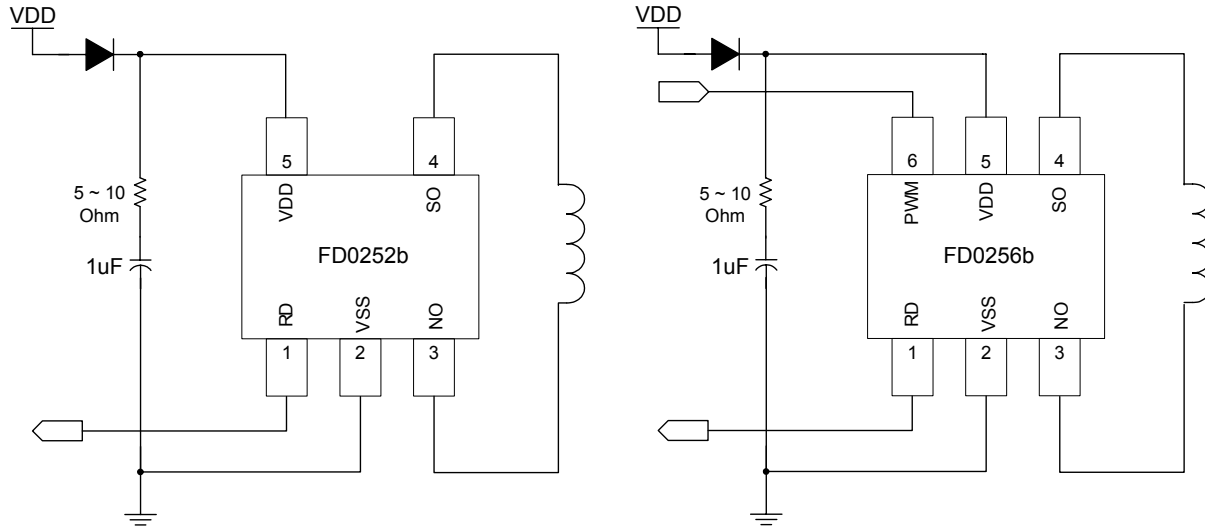

Figure.5

Note. Must use least 1uF(electrolytic) capacitor for the decoupling between VDD and VSS and place the capacitor as close to the IC as possible.



PACKAGE DIMENSION

T825

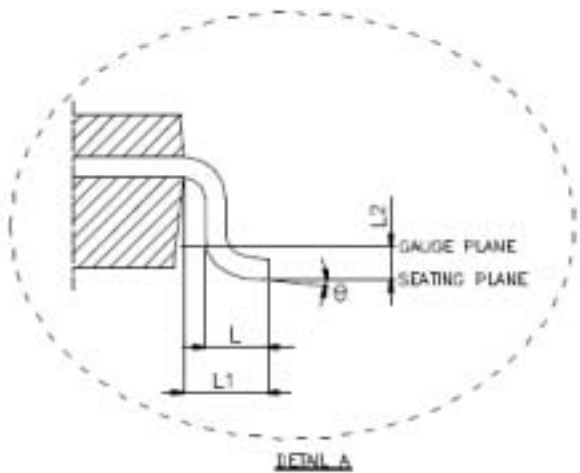
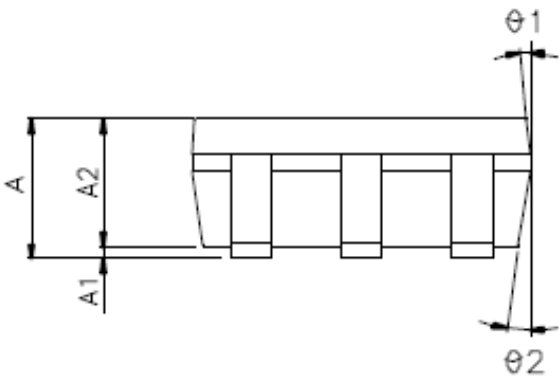
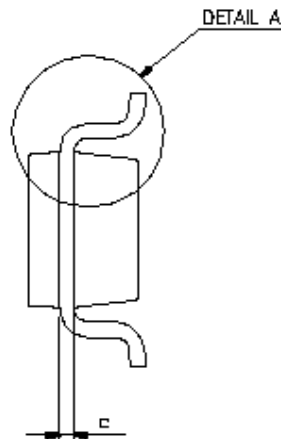
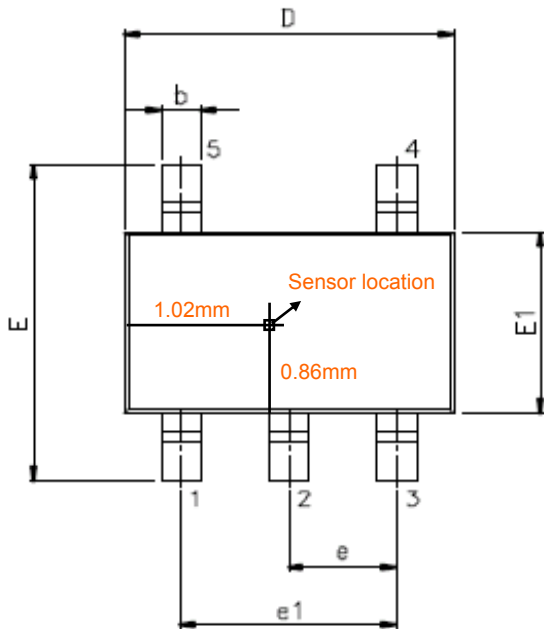

Symbols	Dimension In Millimeters		
	Min	Nom	Max
A	1.05	1.20	1.35
A1	0.05	0.10	0.15
A2	1.00	1.10	1.20
b	0.25	-	0.50
c	0.08	-	0.20
D	2.80	2.90	3.10
E	2.90	3.10	3.30
E1	1.50	1.60	1.70
e	0.95BSC		
e1	1.90BSC		
L	0.50	0.65	0.80
L1	0.80BSC		
L2	0.25BSC		
θ	0°	5°	10°
θ1	3°	5°	7°
θ2	6°	8°	10°



PACKAGE DIMENSION

T826

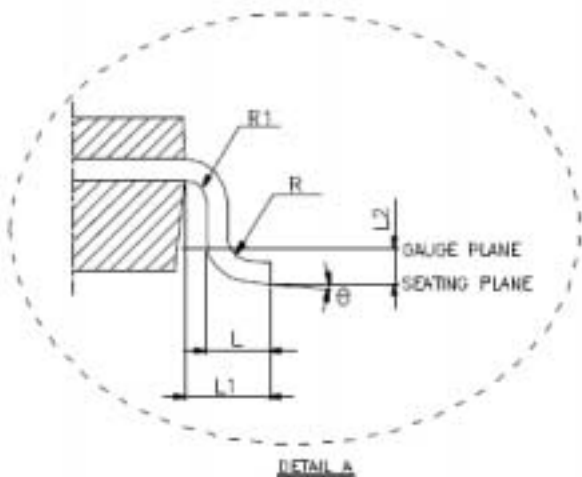
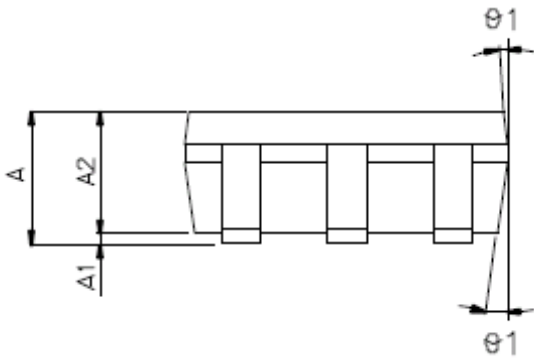
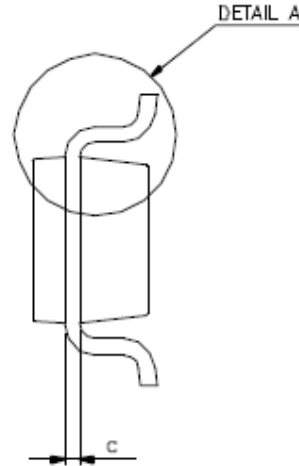
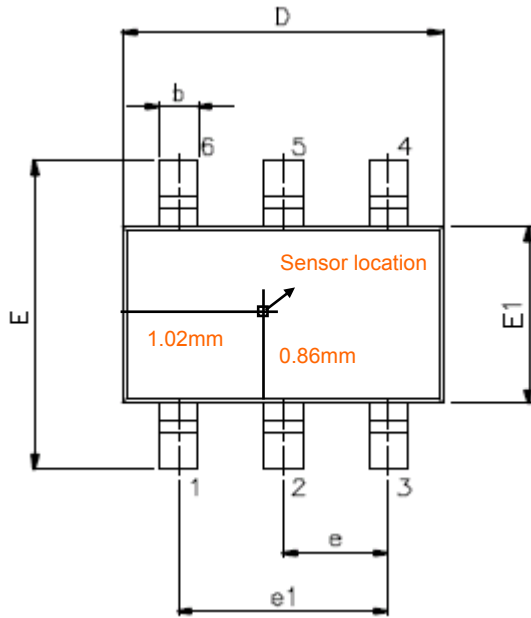

Symbols	Dimension In Millimeters		
	Min	Nom	Max
A	-	-	1.45
A1	-	-	0.15
A2	0.90	1.15	1.30
b	0.30	-	0.50
c	0.08	-	0.22
D	2.90BSC		
E	3.10BSC		
E1	1.60BSC		
e	0.95BSC		
e1	1.90BSC		
L	0.50	0.65	0.80
L1	0.80BSC		
L2	0.25BSC		
R	0.10	-	-
R1	0.10	-	0.25
theta	0°	4°	8°
theta 1	5°	10°	15°

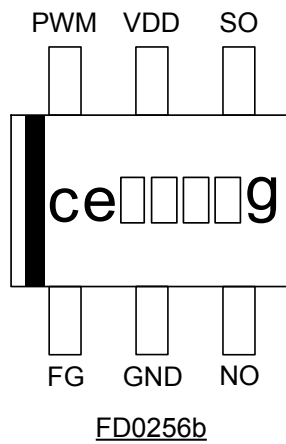
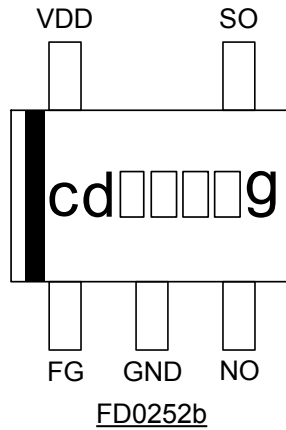
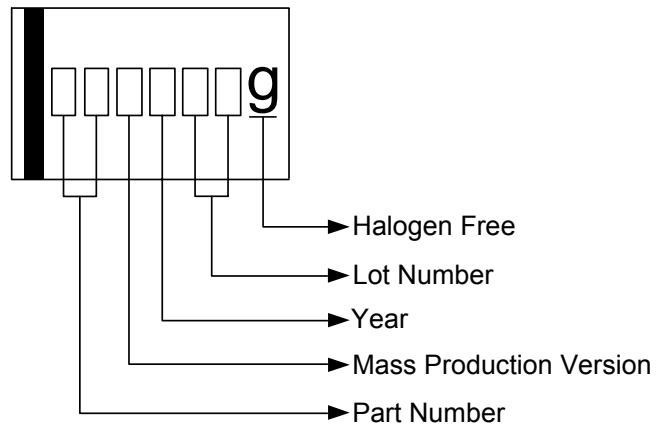
IC PIN CONNECTION

IC DATE CODE DISTINGUISH

ORDER INFORMATION

Part Number	Operating Temperature	Package	Description	Marking
FD0252bR-G1	-20 °C to +105 °C	T825	±25G (B)	cdXXXXg
FD0256bR-G1	-20 °C to +105 °C	T826	±25G (B)	ceXXXXg