

Hall-Effect Smart Fan Motor Controller

Features

- Motor driver with integrated Hall sensor
- Lock-shutdown protection & auto-restart function
- Built output clamp voltage protection for output driver
- Operating voltage: 3.5V ~ 18V
- Output Current: $I_{O(CONT)} = 500\text{mA}$
- Available in SIP-4L packages

Halogen Free

General Description

FD284 is a two coil motor driver with embedded Hall sensor. It integrates the motor driver with the Hall sensor, which simplifies the PCB(printed circuit board) design and make the fabrication of small-size motors possible. Lock-shutdown and auto-restart function restarts the motor after being locked.

The protected action is repeated and periodic during the blocked period. Until the blocking is removed, the motor Recovers and runs normally.

Block Diagram

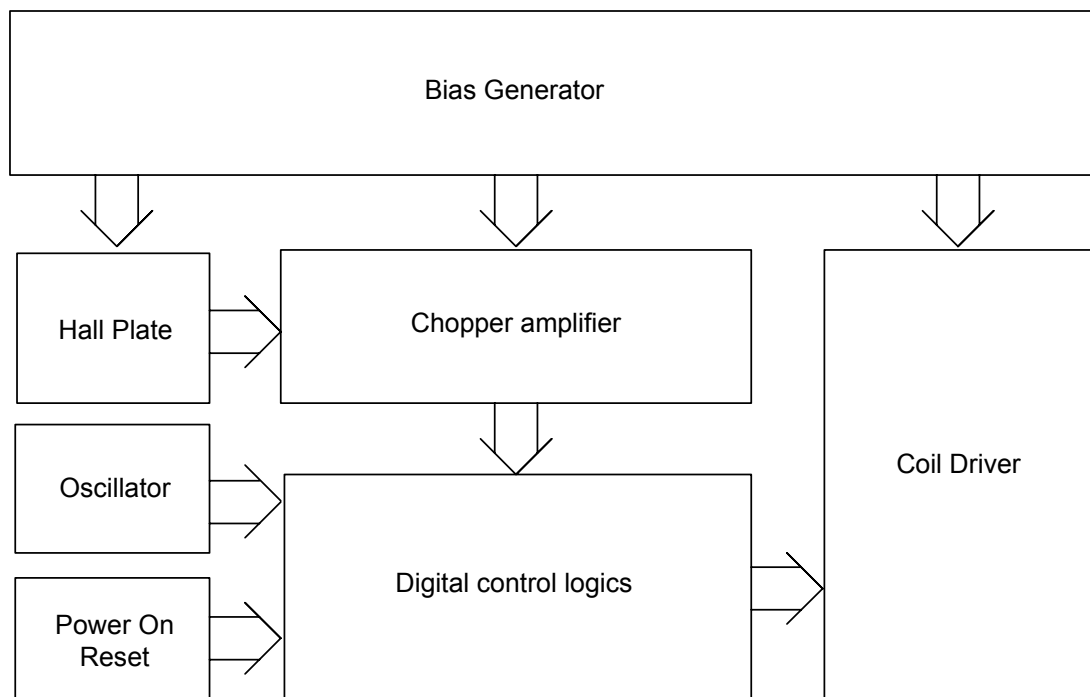
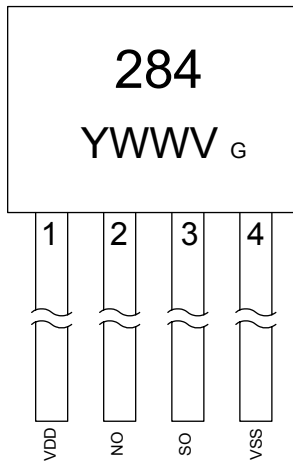
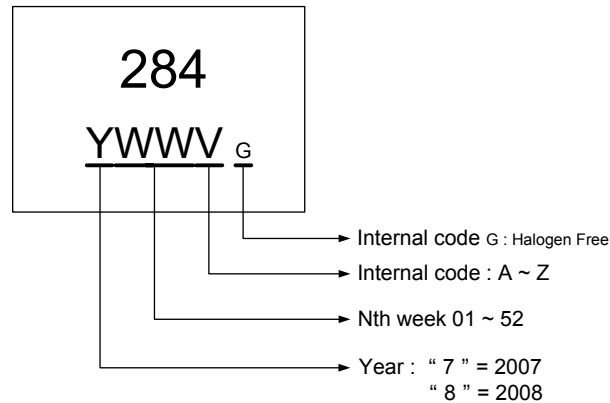

Figure.1

Pin Connection

Figure.2
Marking Distinguish

Figure.3
Pin Descriptions

Name	I/O	FD284	Description
VSS	G	4	Ground
SO	O	3	Driver output
NO	O	2	Driver output
VDD	P	1	Positive power supply

Legend: I=input, O=output, I/O=input/output, P=power supply, G=ground

Functional Descriptions

Refer to the block diagram (Figure.1), FD284 is composed of the following building blocks:

- Bias generator

The bias generator provides precise, temperature- and process-insensitive bias references for the analog circuit blocks. These references guarantee proper operation of the IC under all conditions specified in this specification.

- Oscillator

The built-in oscillator provides the clock signal for the digital control logics

- Power-on Reset

Used to detect the power-up ramp and reset the digital circuits to achieve correct operation as soon as the power is ready.

- Chopper Amplifier

To achieve a higher magnetic sensitivity the chopper amplifier structure is adopted in this design. Use of this structure dynamically removes both the offset and flicker noise at the same time.

- Digital control logics

- Hall sensor part – generates controlling signals for the Hall sensor.
- Coil driver part – generates controlling signals for the Coil driver.



Absolute Maximum Ratings

Parameter	Symbol	Conditions	Values			Unit
			min.	Typ.	max.	
Operating Temperature	T _{OP}	-	-20		100	°C
Storage Temperature	T _{ST}	-	-40		150	°C
Output clamp Voltage	V _C		25		27	V
DC Supply Voltage	V _{DD}	-			18 ⁽¹⁾	V
Supply Current	I _{DD}	-			6	mA
Continuous Current	I _{O(CONT)}				500	mA
Peak Current	I _{O(PEAK)}				700	mA
Junction temperature	T _J				150	°C
Power Dissipation	P _D	SIP-4L			600	mW
Thermal Resistance	θ _{JC}	SIP-4L		209		°C/W
Magnetic Flux Density	B				Unlimited	Gauss
IR-Reflow Lead Temperature		10sec			260	°C

Note 1: V_{DD}=18V, if V_{BEMF} is lower than the output clamp voltage (V_C).

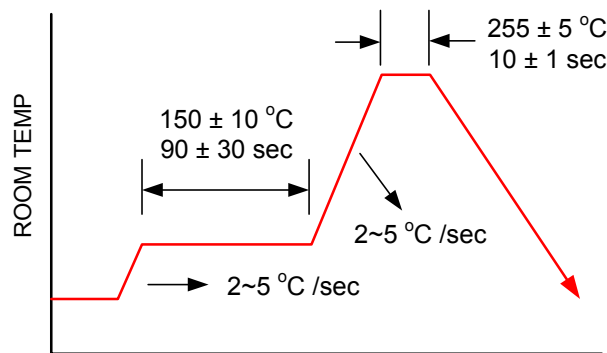
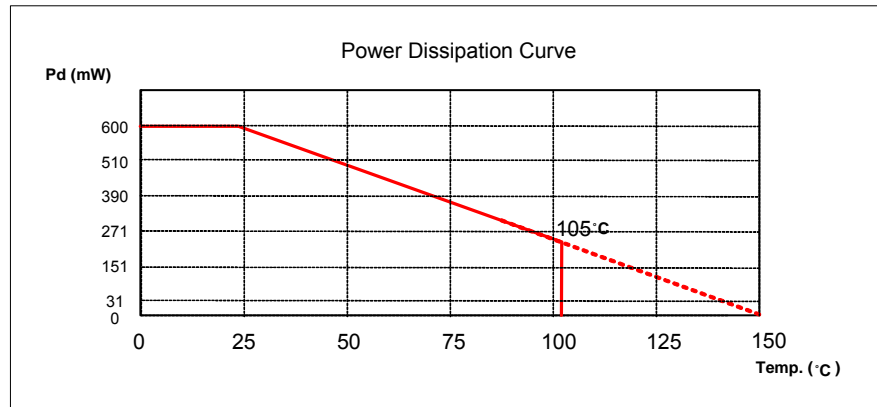

IR-ReFlow Soldering Condition



Lock shutdown – Restart Timing Description:

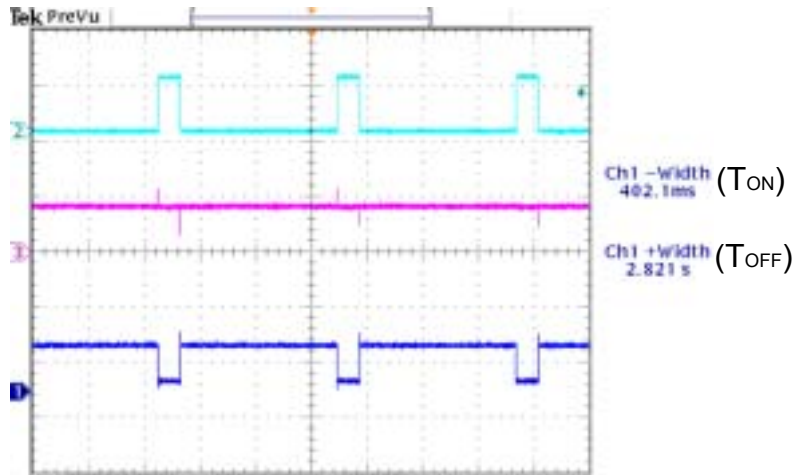

Channel2: V_{DD} pin current waveform

Channel3: Output (SO pin) voltage waveform

Channel1: Output (NO pin) voltage waveform

Note: The North pole (B > Bop) is applied facing the branded side of the package.

Application Circuit Reference

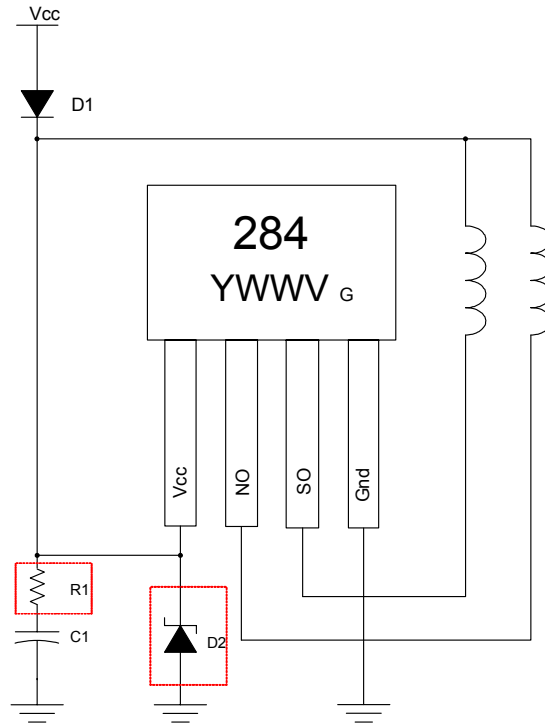
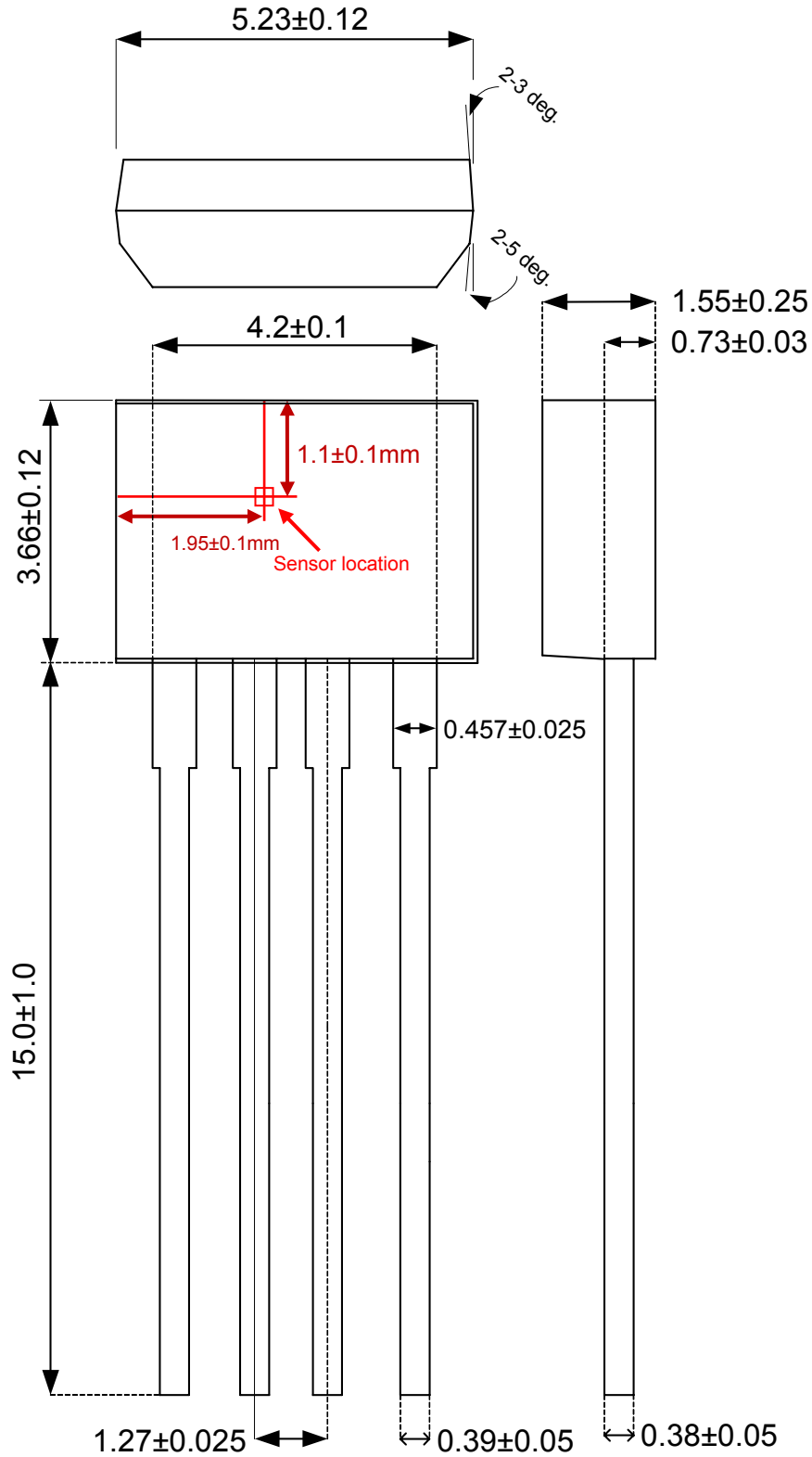

Figure.10

Note: $C1=1\mu F$, $R1=2\sim 5\text{ ohm(option)}$, $D2(option)$ breakdown voltage 16V



Package Dimension (Unit: mm)
SIP-4L(Halogen Free)





Packing Specification

BAG & BOX DIMANSION

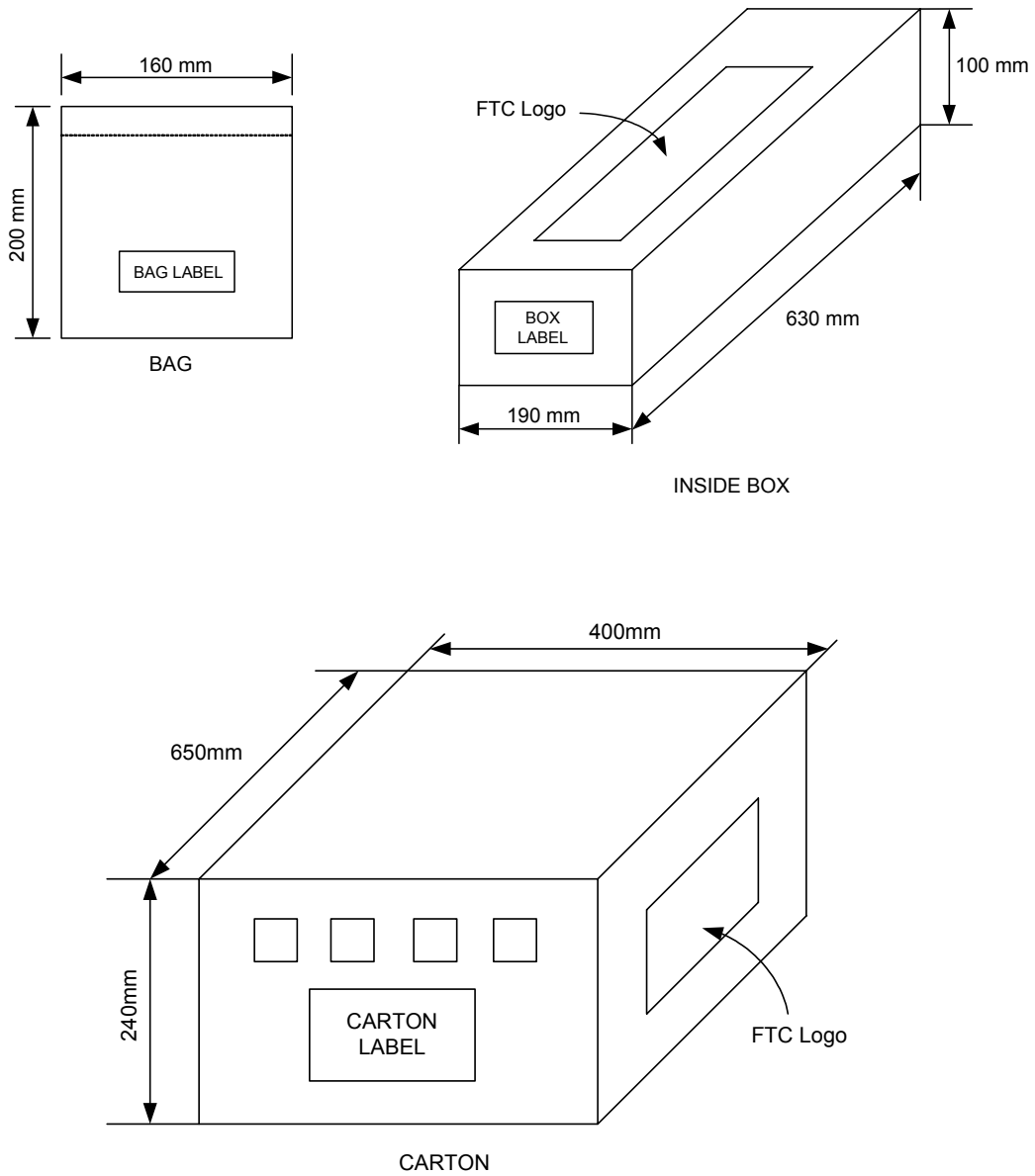

Packing Quantity Specifications

1000 EA / 1 BAG

25 BAGS / 1 INSIDE BOX

4 INSIDE BOXES / 1 CARTON



Order Information

Part Number	Operating Temperature	Package	Description	Marking
FD284-G1	-20 °C to +85 °C	SIP-4L	±20G (B)	-