



Low-Power Hall Switch

FEATURES

- Micro power consumption
- 2.4V to 5.5V battery operation
- Chopper Amplifier based design:
Insensitive to noise and offset caused by process variations, operating temperatures and mechanical stress
- Digital output
- Programmable output direction
- CMOS process

GENERAL DESCRIPTION

FD2H001A/BY_LF is a low-power integrated Hall switch designed to sense the applied magnetic flux density and give a digital output, which indicates the present condition of the magnitude sensed. One example of the applications is the on/off switch in cellular flip-phones.

The micro power design is especially suitable for battery-operated systems such as cellular phones or laptop computers, in which power consumption is one major concern. The typical power consumption of FD2H001A/BY_LF is below 10 μ W at 2.7V.

The magnetic switching points are precise and insensitive to process and temperature variations.

For FD2H001AY_LF, the output will be at the “low” level when no magnetic field is applied. When the applied magnetic flux density is stronger than the switching threshold, the output would be at the “high” level.

For FD2H001BY_LF, the output will be at the “high” level when no magnetic field is applied. When the applied magnetic flux density is stronger than the switching threshold, the output would be at the “low” level.

BLOCK DIAGRAM

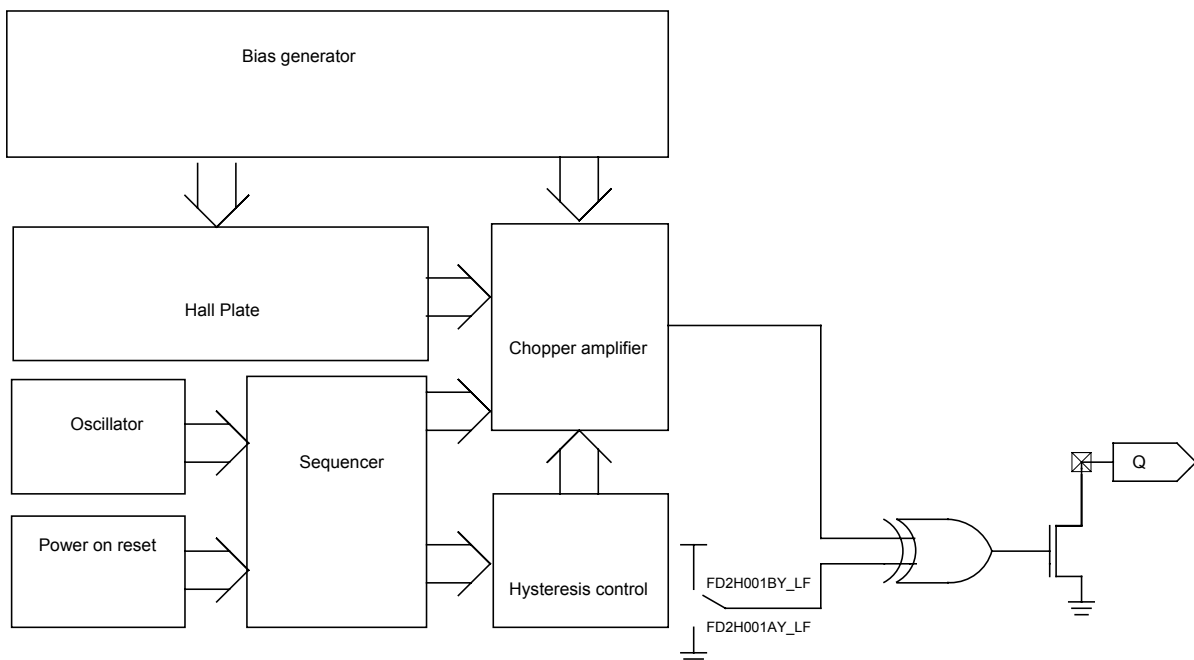

Figure.1



PIN CONNECTION

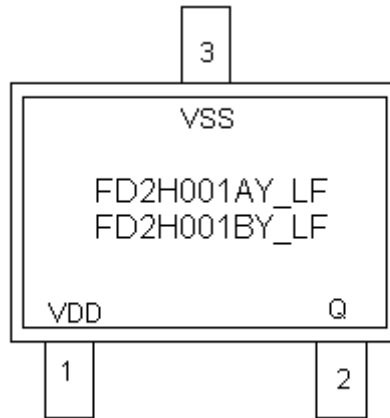

Figure.2

PIN DESCRIPTIONS

Name	I/O	Description
Q	O	Open Drain output
VDD	P	Positive supply
VSS	G	Ground

Legend: I=input, O=output, I/O=input/output, P=power supply, G=ground

2.0 FUNCTIONAL DESCRIPTIONS

Refer to the block diagram (Figure.1), FD2H001A/BY_LF is composed of the following building blocks:

● Bias generator

The bias generator provides precise, temperature and process insensitive current sources for both the Hall plate and the chopper amplifier. These current sources in turn guarantee proper operation of the chip and precise switching thresholds under all kinds of environments specified in the specification.

● Oscillator + Sequencer

The built-in oscillator provides the clock signal, which is taken by the sequencer to determine the periods of the operating phase and the stand-by phase. Typically the operating time is about 60us and the stand-by time is 150ms. Using such a clocking scheme, the average power consumption is almost equal to that in the stand-by phase, which is under 10μW at 2.7V.

● Power on Reset

Used to detect the power-up ramp and reset the digital circuits to attain correct operation as soon as the power is ready.

● Chopper Amplifier

To achieve a higher resolution the chopper amplifier structure is adopted in this design. Use of this structure dynamically removes both the offset and flicker noise at the same time.

● Hysteresis Control

This block determines the switching threshold of the Hall switch in different situations.



ABSOLUTE MAXIMUM RATINGS

Parameter	Conditions	Values		Unit
		min.	max.	
Ambient Operating Temperature	-	-40	85	°C
Storage Temperature	-	-40	150	°C
DC Supply Voltage	-	2.4	5.5	V
Supply Current	-	-1	2.5	mA
Programming Pin Voltage (only available for FD2H001L-LF)	With respect to VSS	-0.3	5.5	V
Magnetic Flux Density	-		unlimited	mT
Lead Temperature	10sec	-	260	°C

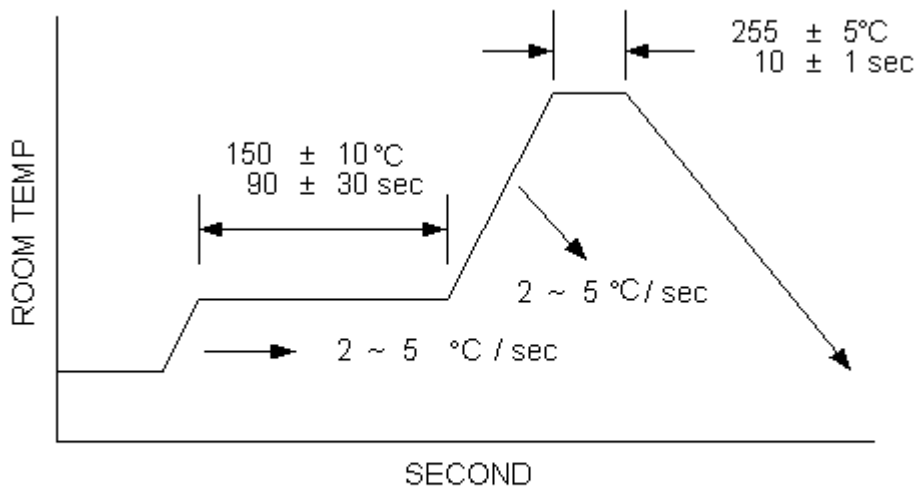

Soldering Condition



OPERATING CONDITIONS

Parameter	Conditions	Values			Unit
		min.	typ.	max.	
Supply Voltage	-	2.4	2.7	5.5	V
Output Voltage	-	-0.3	2.7	5.5	V
Ambient Temperature	-	-40	25	85	°C

ELECTRICAL CHARACTERISTICS

Parameter	Conditions	Values			Unit
		min.	typ.	max.	
Average Supply Current			3 ¹	20	µA
Average Supply Current (operating phase)			1.1 ¹		mA
Average Supply Current (stand-by phase)			2.5 ¹		µA
Output Saturation Voltage			0.1		V
Output Leakage Current			0.01		µA
Operating time			60		µs
Standby time			150		ms
Duty cycle			0.04		%

1. operating voltage 2.7V

MAGNETIC CHARACTERISTICS

FD2H001AY_LF

Parameter	Conditions	Values			Unit
		min.	typ.	max.	
Operate Points (B _{OP})		30	45	60	G
Release Points (B _{RP})		40	55	70	G
Hysteresis		5	10	15	G

FD2H001BY_LF

Parameter	Conditions	Values			Unit
		min.	typ.	max.	
Operate Points (B _{OP})		40	55	70	G
Release Points (B _{RP})		30	45	60	G
Hysteresis		5	10	15	G



MAGNETIC FLUX

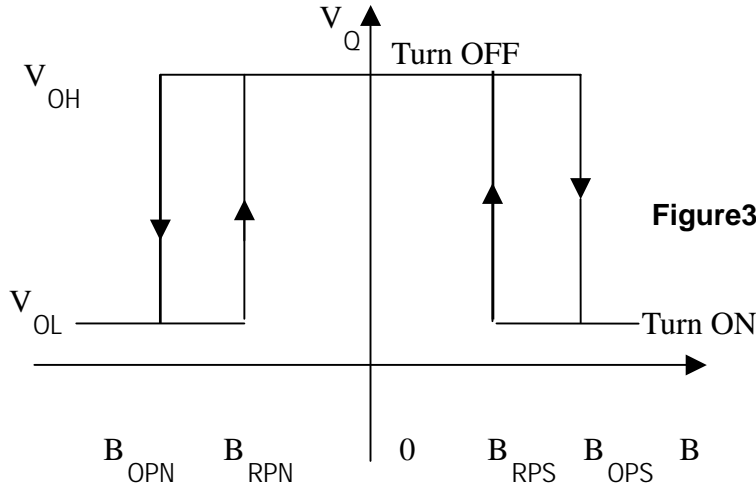

Figure3 . FD2H001BY_LF

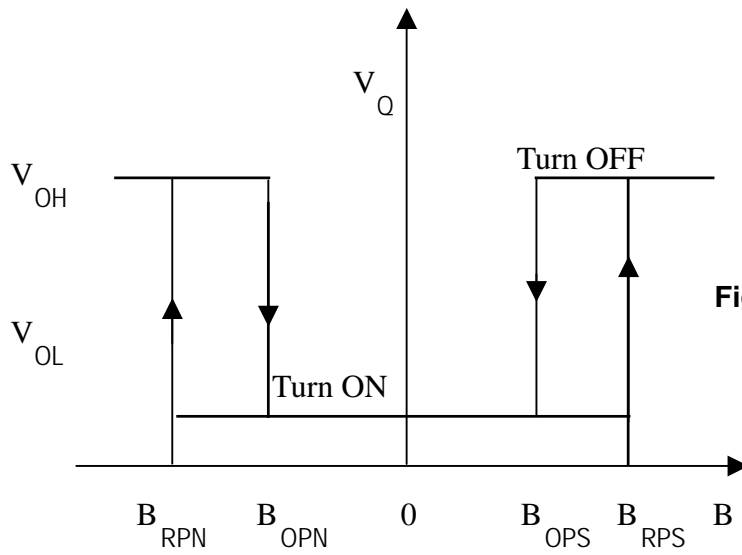

Figure4 . FD2H001AY_LF



TYPICAL CHARACTERISTICS (For Example FD2H001BY_LF)

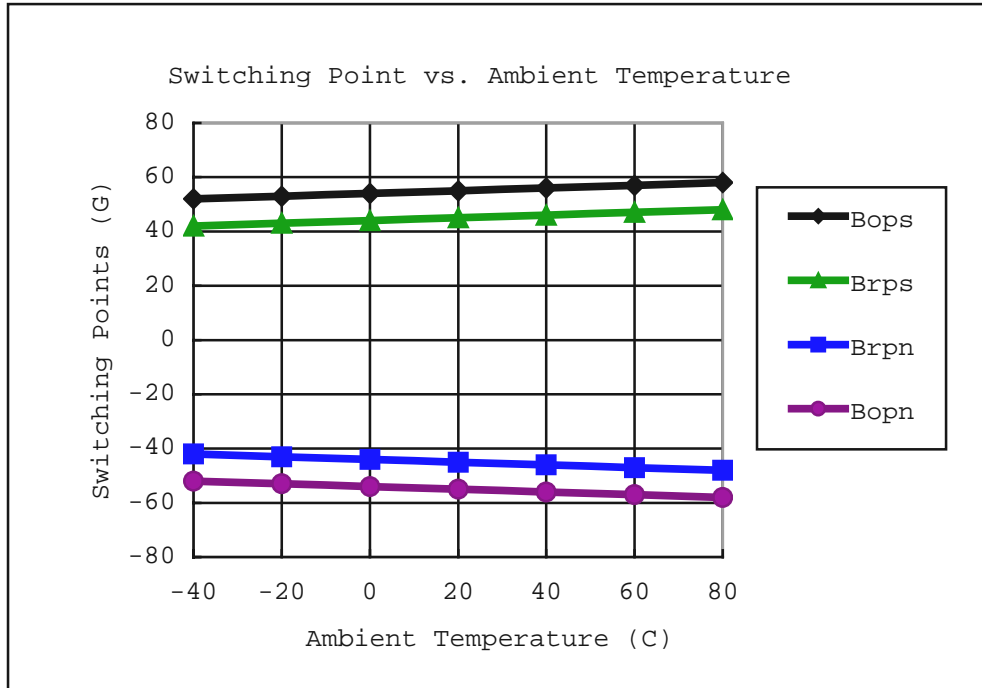

Figure.5 Magnetic Switch Points Versus Ambient Temperature (VDD=2.7V)

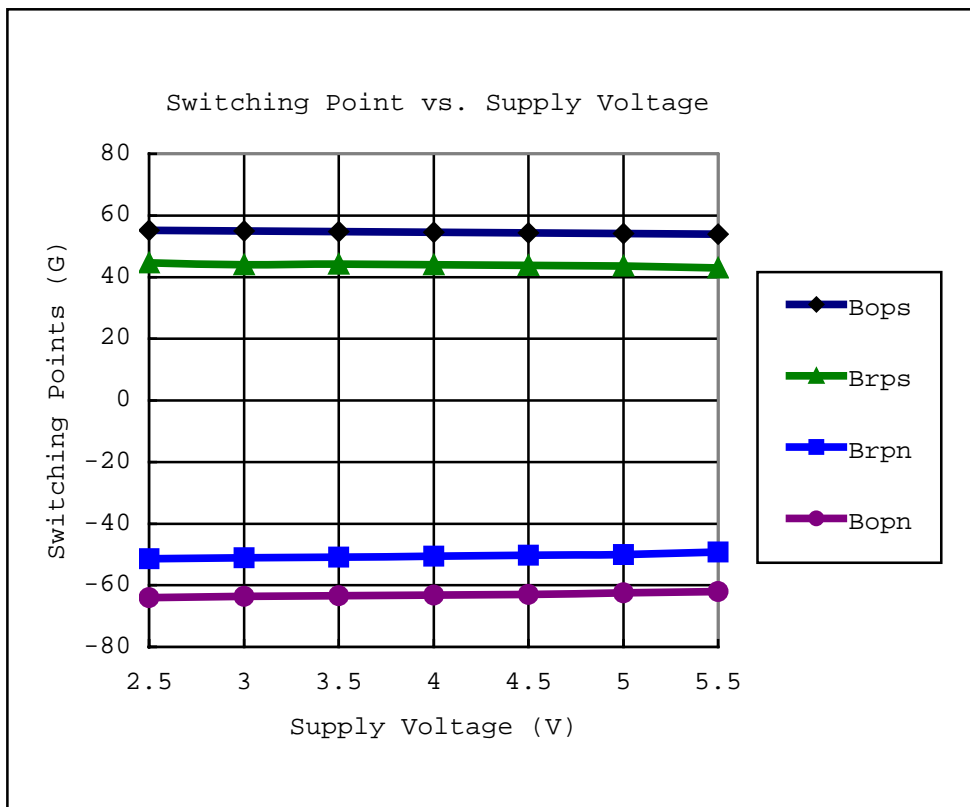

Figure.6 Magnetic Switch Points Versus Supply Voltage (Ta=25C degree)

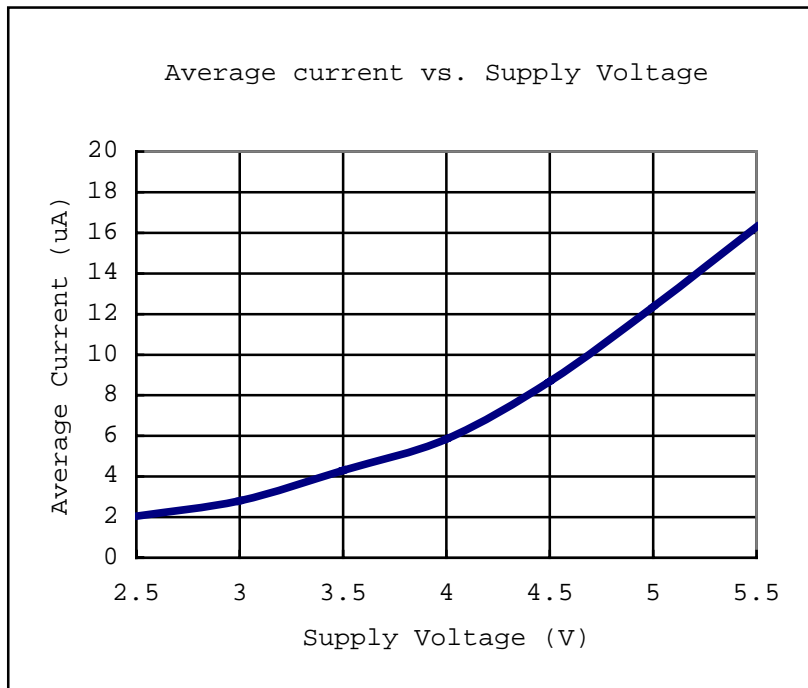

Figure.7 Average Current Versus Supply Voltage (Ta=25C degree)

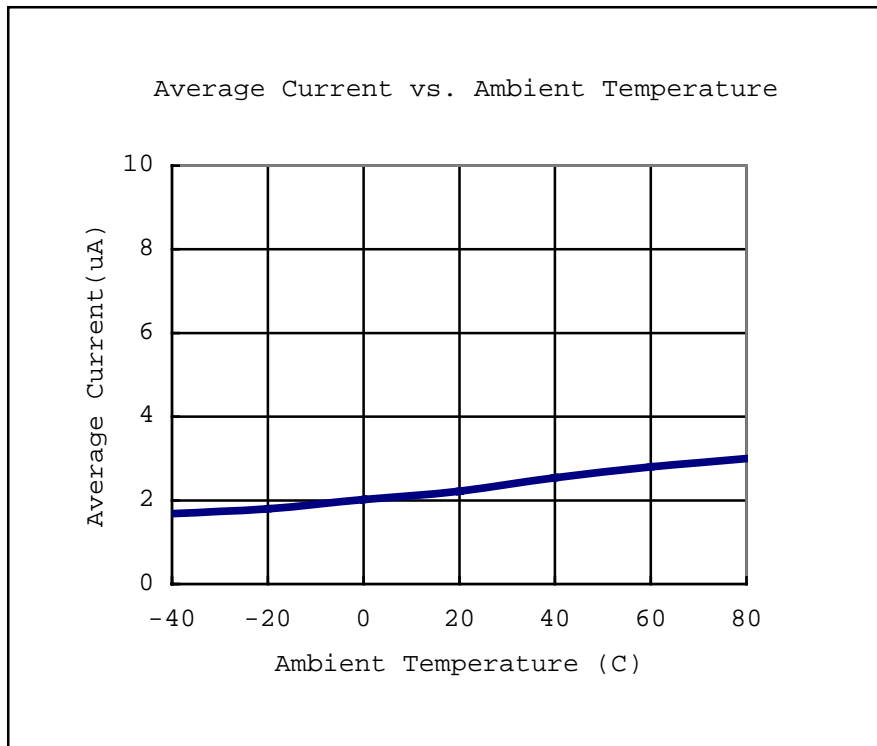

Figure.8 Average Current Versus Ambient Temperature (VDD=2.7V)



PACKAGE DIMENSION

Unit : MM

SOT23-3L

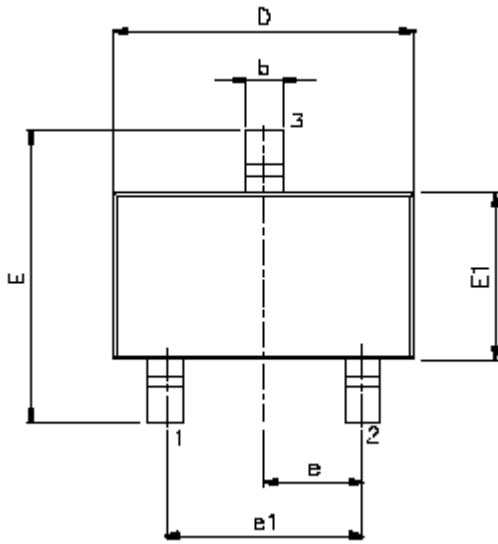

Symbols	Dimension In Millimeters		
	Min	Nom	Max
A	-	-	1.45
A1	-	-	0.15
A2	0.90	1.15	1.30
b	0.30	-	0.50
c	0.08	-	0.22
D	2.90BSC		
E	2.80BSC		
E1	1.60BSC		
e	0.95BSC		
e1	1.90BSC		
L	0.30	0.45	0.60
L1	0.60BSC		
L2	0.25BSC		
R	0.10	-	-
R1	0..10	-	0.25
θ	0°	4°	8°
$\theta 1, \theta 2$	5°	10°	15°

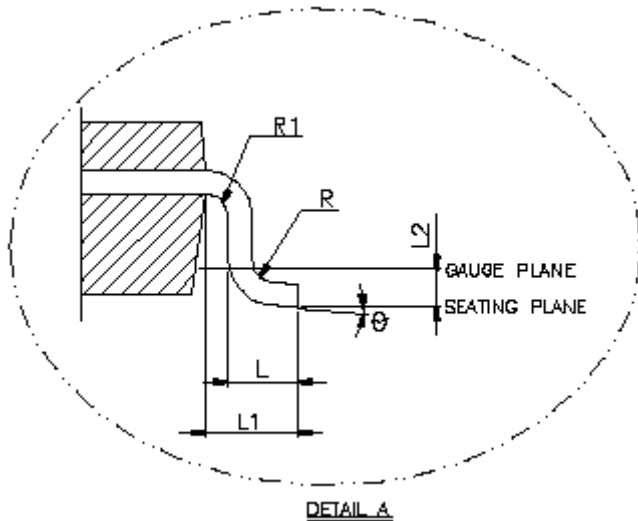

DETAIL A

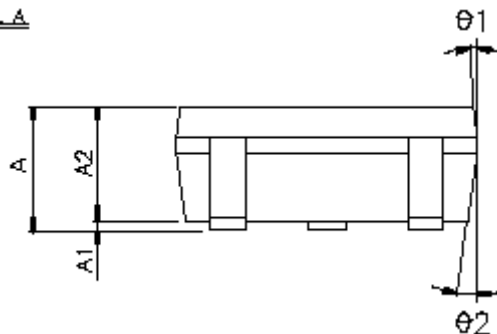
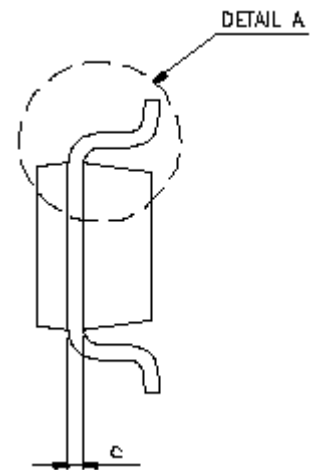



PACKING SPECIFICATION (Tapping Reel)

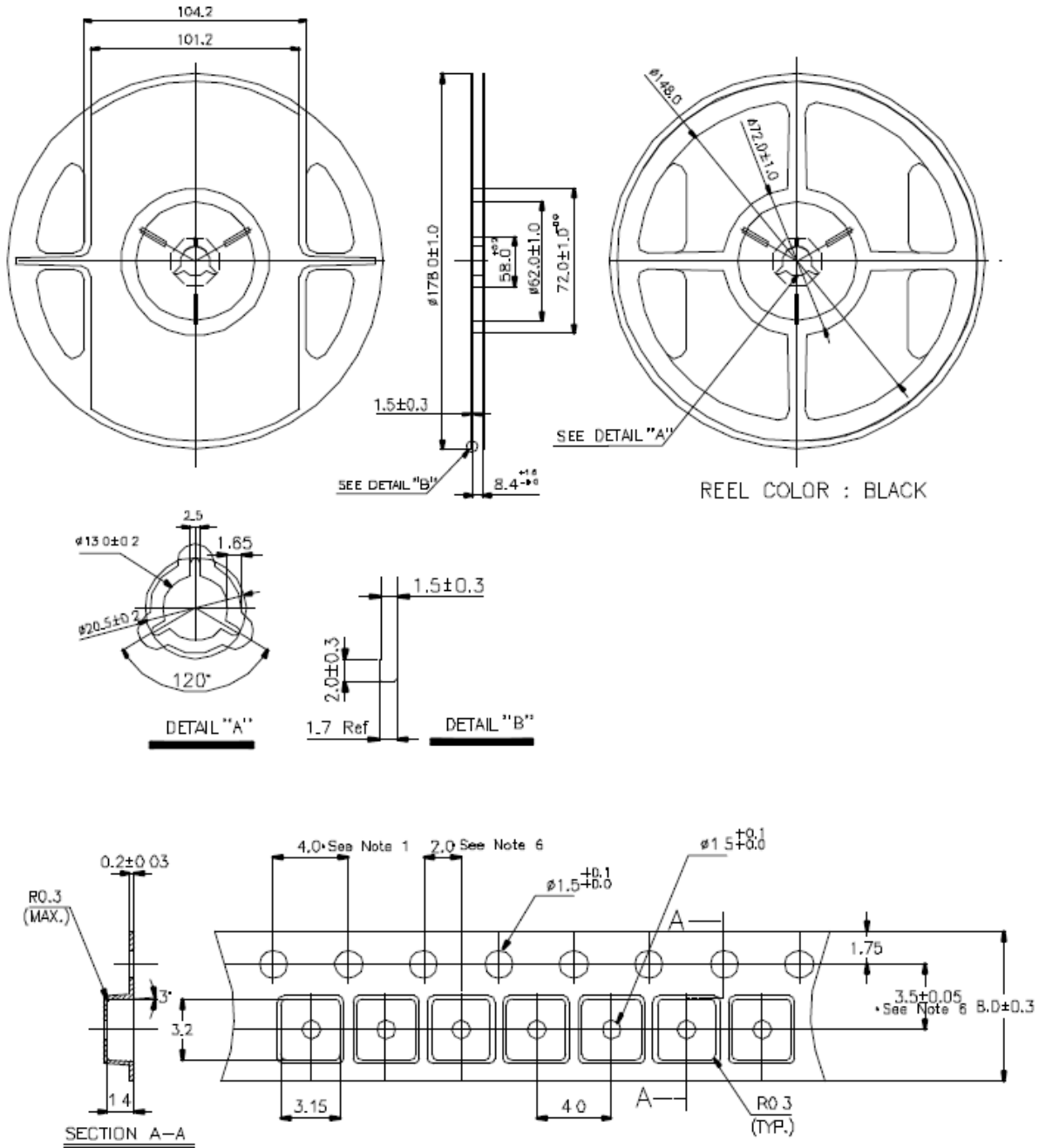

PACKING QUANTITY SPECIFICATION

2500ea / 1 Reel

5 Reels / 1 INSIDE BOX

2 INSIDE BOXES / 1 OUTSIDE BOX



APPLICATION REFERENCE

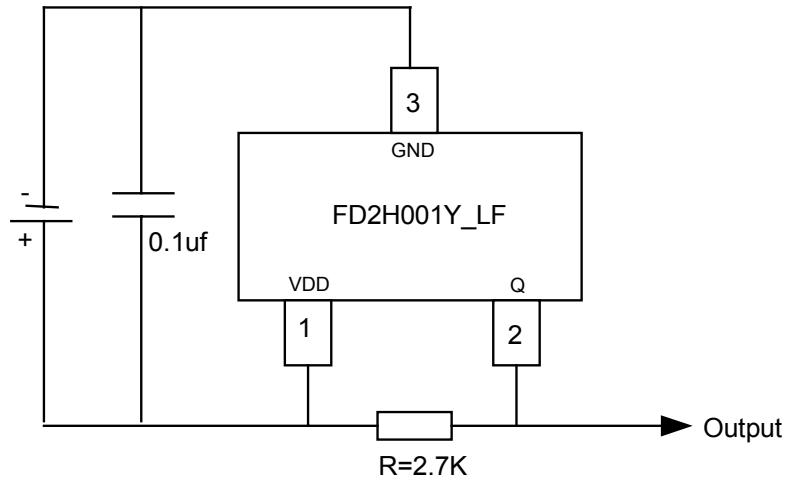
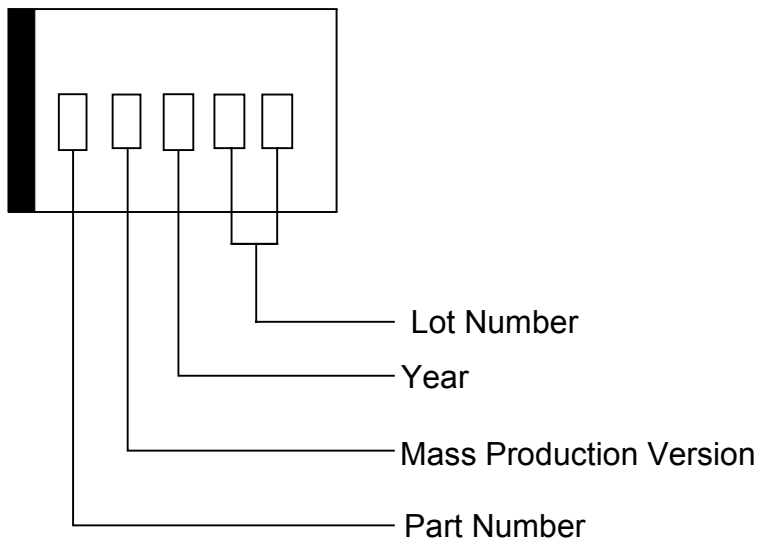

Figure10 . FD2H001A/BY_LF Application Circuit

IC DATE CODE DISTINGUISH





**FEELING
TECHNOLOGY**

FD2H001A/BY_LF

ORDER INFORMATION

Tapping Reel :

Type	Marking	Package
FD2H001AYR_LF	BCYNN	SOT23-3L
FD2H001BYR_LF	CCYNN	SOT23-3L