

2 PHASE DC MOTOR DRIVE IC

GENERAL DESCRIPTION

The FS212, a 1-chip composed of hall sensor and output coil drivers, applied to 2-phase DC motor. The high sensitivity of Hall effect sensor is suitable for motors from mini-type CPU coolers to blowers and DC fans. Typical operation current is 0.4A and operating voltage range is wide. Lock shutdown, to connect with a capacitor, provides a programmable time of lock shutdown and re-start during the motor is locked.

Using few external components, FS212, a high performance integrated IC, is designed for a 2-phase DC motor circuit. The circuit diagram of the typical application example is as below.

FEATURES

- 1 chip hall sensor/drivers
- Wide operating voltage range: 4.0V~20V
- Output sink current up to 0.55A
- Low quiescent supply current under 5mA
- Built-in Lock Shutdown and Re-start function
- Package : TO-92SP-4

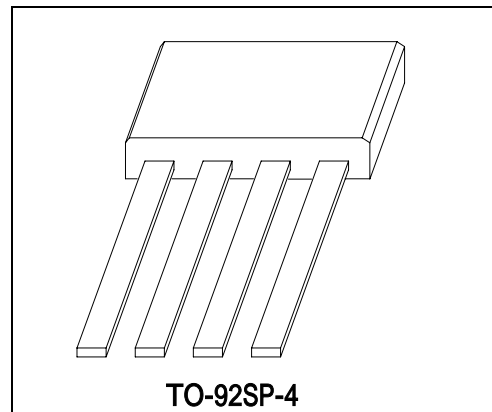

TYPICAL APPLICATION CIRCUIT

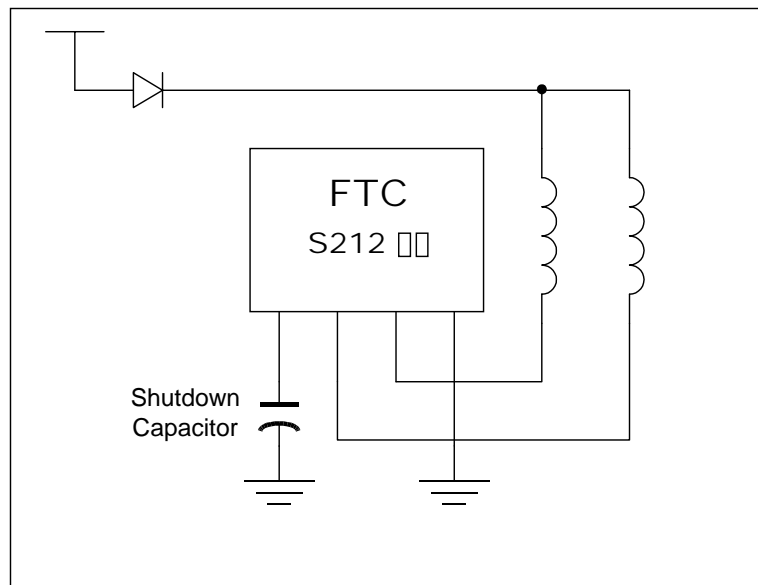

FUNCTIONAL BLOCK DIAGRAM

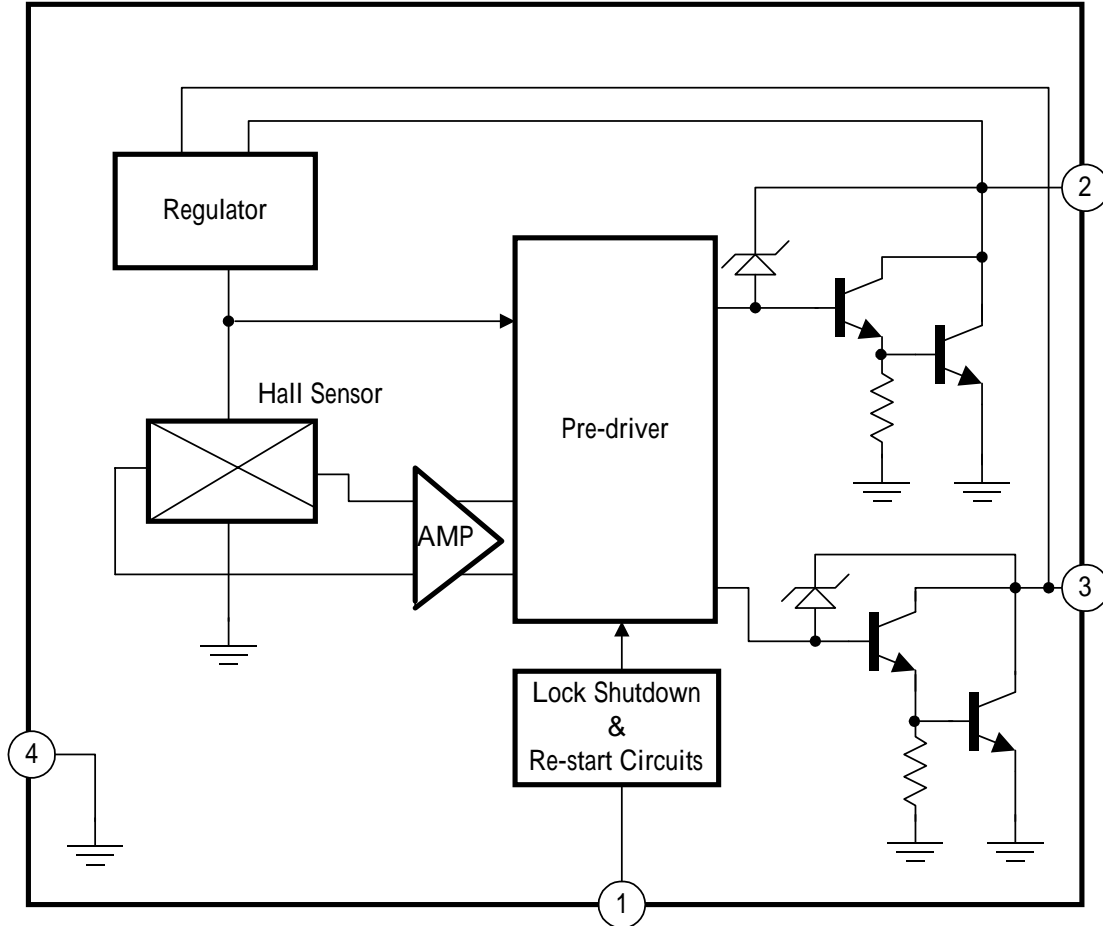

MARK VIEW

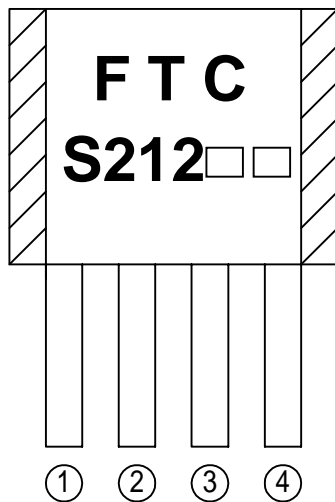

PIN DESCRIPTION

NAME	NO.	STATUS	DESCRIPTION
SC	1	I	Shutdown Control input A capacitor is connected to this pin to decide the lock shutdown and re-start timing.
NO	2	O/P	Coil driver output It is low state during the N magnetic field. /Power input
SO	3	O/P	Coil driver output It is low state during the S magnetic field. /Power input
GND	4	P	IC Ground

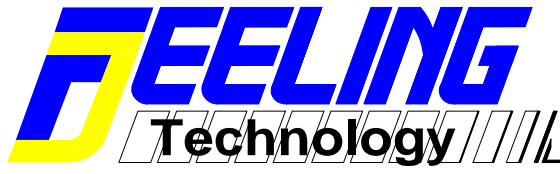

FS212

ABSOLUTE MAXIMUM RATINGS

Zener Breakdown Voltage (V_Z)	-----	35V
NO/SO Pin Voltage (V_{CP} (Note 1))	-----	30V
Peak Sink Current (I_o)		
Hold Current	-----	550mA
Continuous Current	-----	400mA
Peak Reverse Current (I_R)	-----	100mA
SC pin OFF Voltage (V_{SC})	-----	$V_{CC}-0.7V$
Power Dissipation		
$T_a=25$	-----	600mW
$T_a=70$	-----	450mW
Operating Temperature Range	-----	-20°C 85°C
Storage Temperature Range	-----	-65°C 150°C
Junction Temperature	-----	+150°C
Lead Temperature (Soldering, 10 sec)	-----	+230°C

Note1 V_{CP} mean Coil Power

DC ELECTRICAL CHARACTERISTICS

PARAMETER	SYMBOL	TEST CONDITIONS	MIN	TYP	MAX	UNIT
Minimum Operating Voltage	V_{CP}	No use pin is open (Fig1)		4.0		V
Maximum Operating Voltage	V_{CP}	$I_{CP} < 10mA$ No use pin is open (Fig1)		20.0		V
Quiescent Supply current	I_{CP}	No use pin is open $V_{CP} : 4.0V \sim 20V$ (Fig1)	2.0		6.0	mA
NO/SO Saturation Voltage	V_{SAT}	$I_o = 300mA$ (Fig1)			1.5	V
Output Reset Voltage	V_{SCRST}	SC capacitor is $1 \mu F$ (Fig2)		0.3		V
Output Off Voltage	V_{SCOFF}			0.7		V
Output Re-start Voltage	V_{SCRS}		1.5	1.7	1.9	V
SC charged current	I_{CHG}	(Fig3)		0.8		μA
Note: Fig1 The IC output state is under N magnetic field.						

AC ELECTRICAL CHARACTERISTICS

PARAMETER	SYMBOL	TEST CONDITIONS	MIN	TYP	MAX	UNIT
Rise time	(t_r)	$RL=1K \ CL=10pF$ (Fig3)			500	nS
Fall time	(t_f)	$RL=1K \ CL=10pF$ (Fig3)			500	nS

MAGNETIC CHARACTERISTICS

Test Circuit : Fig1 Test Circuit (R1=R2=500 , V1=V2=15V)

FS212-A	Ta=-20 85			
PARAMETER	MIN	TYP	MAX	UNIT
Bop		+60		G
Brp		-60		G
Bhys			120	

FS212-B	Ta=-20 85			
PARAMETER	MIN	TYP	MAX	UNIT
Bop		+90		G
Brp		-90		G
Bhys			180	

V_{NO}

V_{SO}

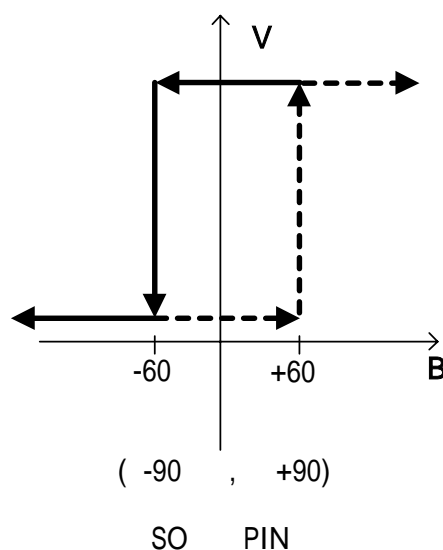
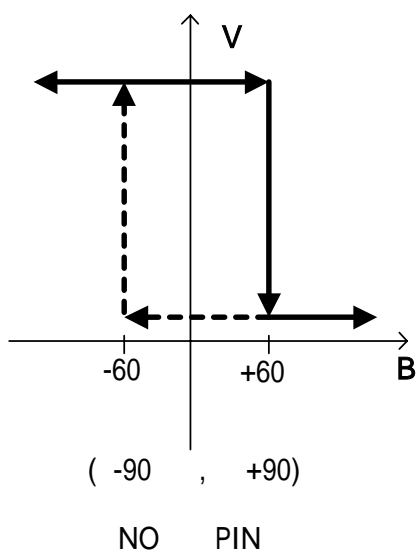

TYPICAL CHARACTERISTICS

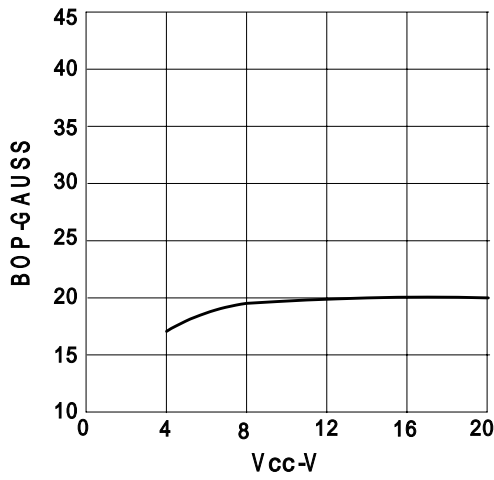

Figure 1

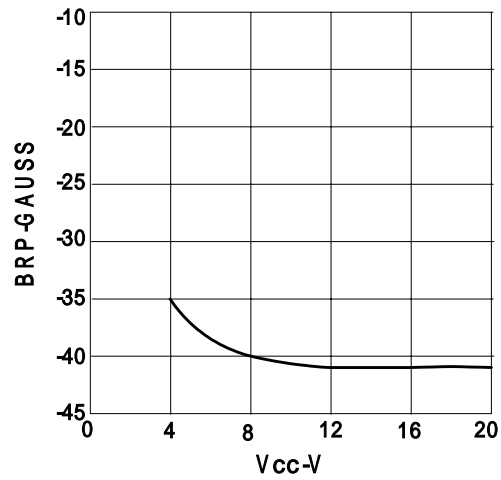

Figure 2

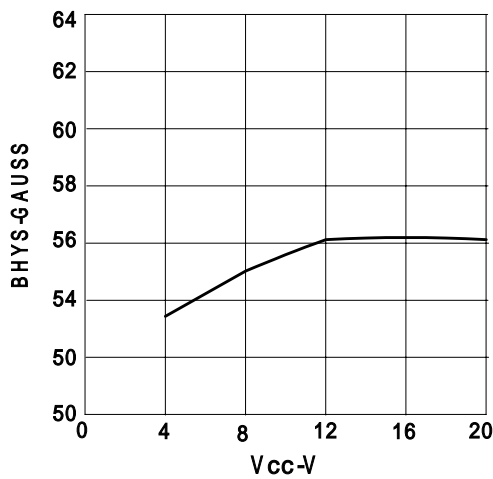

Figure 3

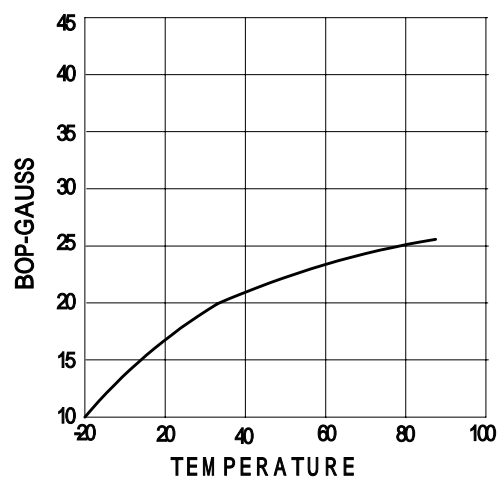

Figure 4

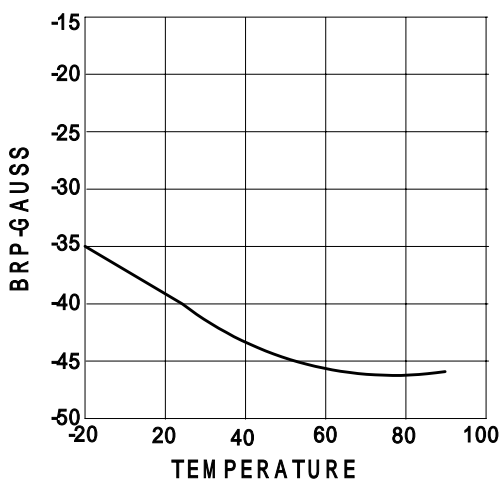

Figure 5

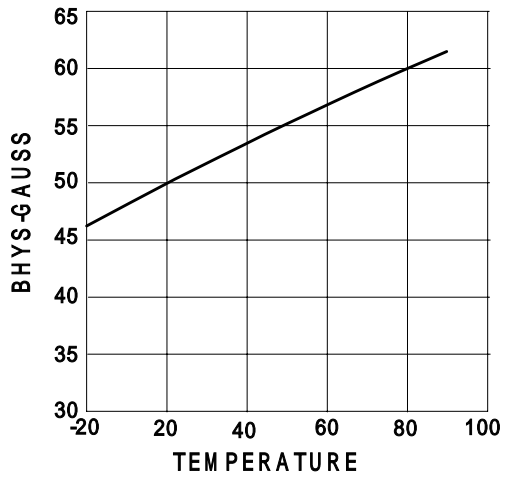

Figure 6

TEST CIRCUITS:

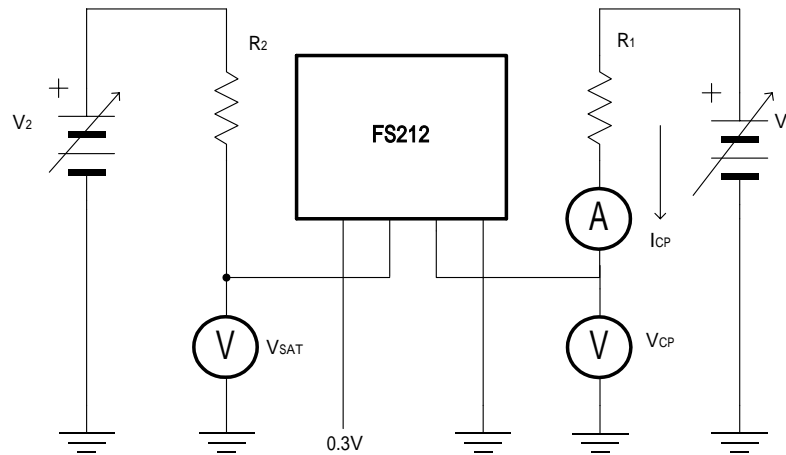

Fig 1 Test Circuit

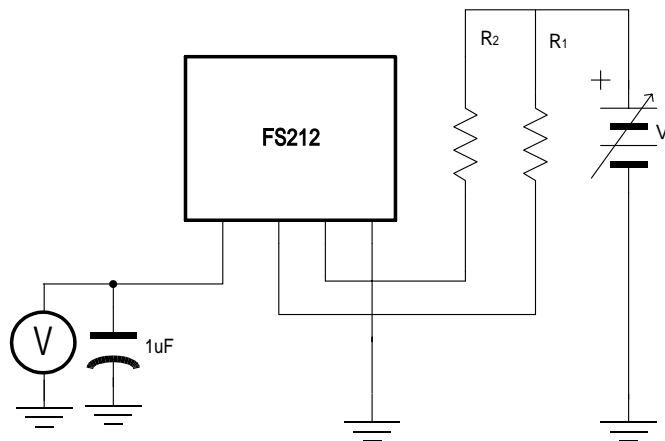

Fig 2 Test Circuit

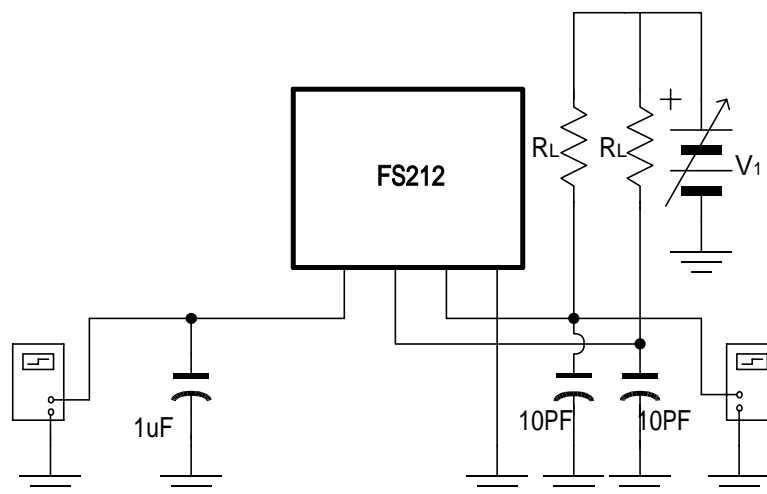

Fig 3 Test Circuit

FUNCTION DESCRIPTIONS

Hall Sensor Location

The Fig 4 is the hall sensor location, where marks the IC number. The best sensitivity, which can be intensified as much as possible, depends on the vertical distance and position between magnetic pole and the hall sensor (Fig 5). For the 2-phase motor, this design is very important.

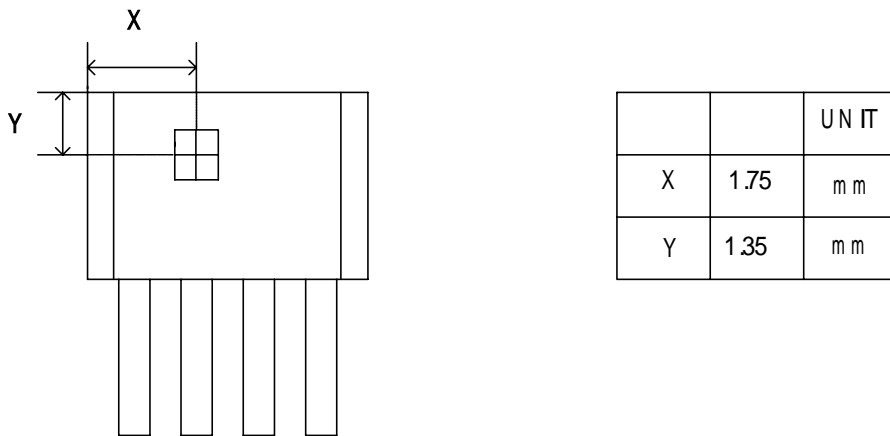

Fig 4 FS212 Hall Sensor Location

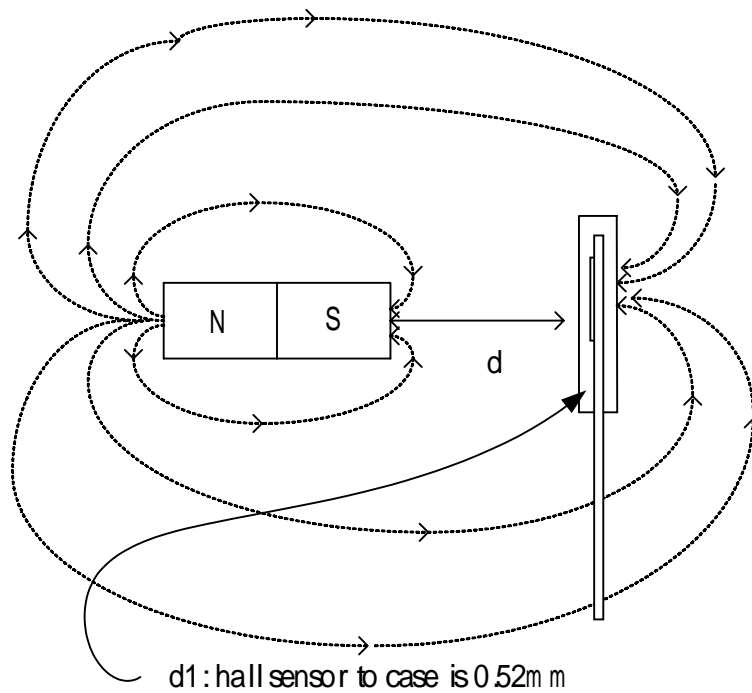

Fig 5 Magnetic Distribution and Z-axis position

Darlington-pair Transistor Output

The Fig 6 is the circuit diagram of Darlington-pair transistor. Under the heavy current loading, the power loss of the high saturation voltage can be calculated into the following formula:

$$P_C = (V_{BEQ1} + V_{CE(SAT)Q2}) * I_o$$

According to the IC package and the curve of the power loss, the P_c should be applied to and within the safety value.

30V is the voltage of Zener breakdown diode. However, if the voltage, excluding that of the power supply, is more than 30V under the long-time operation, the diode will be destroyed.

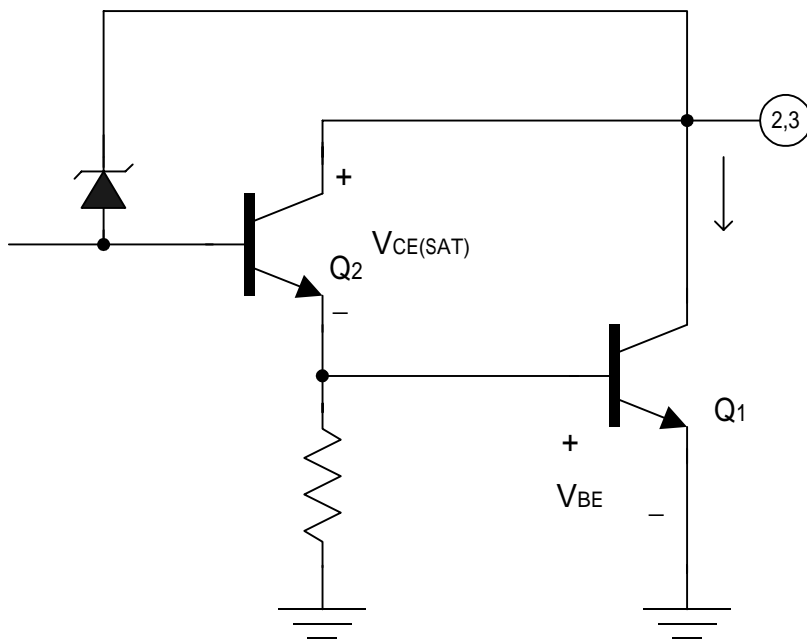

Fig 6 Darlington-pair Transistor Output

Lock Shutdown and Re-start Circuits and Timing Diagram

Fig 7 the shutdown control (SC) pin input connected with the capacitor to decide the shutdown to re-start time with internal charge current and reset circuit. The capacitor is charged to “A” point and shutdown (Figure 8, typical value is 0.7V) by an internal constant current source as a situation of the motor is locked for a long-time condition cause DC motor malfunction.

And the capacitor is discharged to “C” point (Figure 8, typical value is 0.3V) until internal circuits detect a re-start threshold voltage (“B” point, typical value is 1.7V), and then FS212 would let the motor have a torque for rotation. The calculated formula of shutdown timing is :

$$t = C \frac{\Delta v}{i} \quad i = 0.8\mu A, \Delta v = (1.7-0.7)V$$

Fig 8 illustrates the relation of FS212 output stages and SC pin timing waveform.

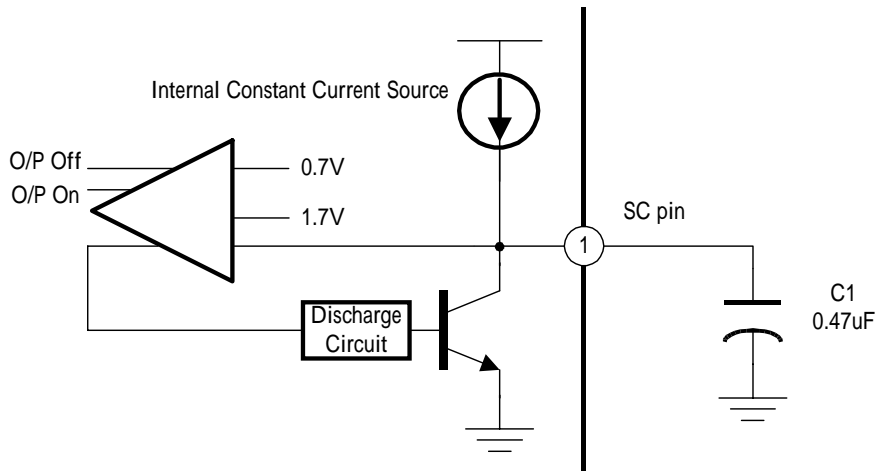

Fig 7 SC Block Diagram

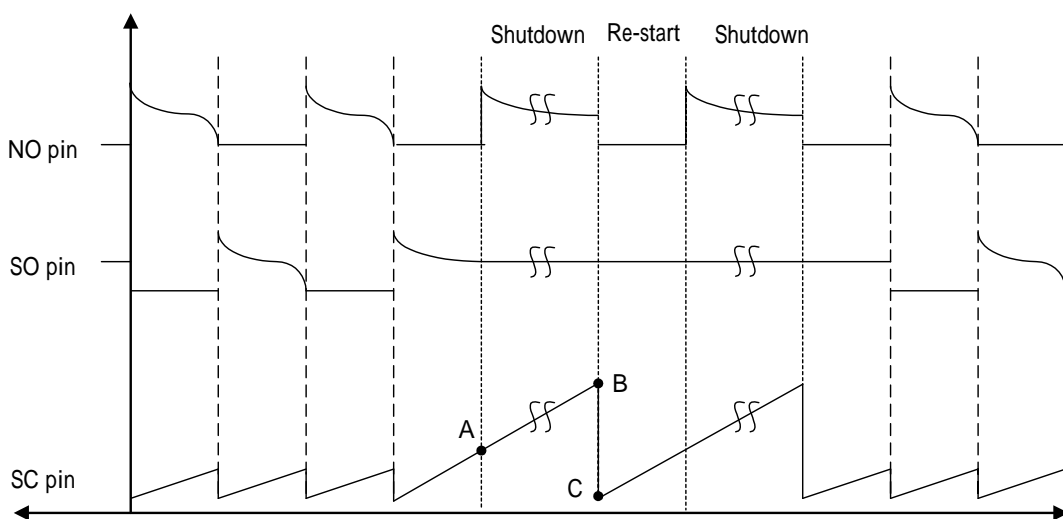

Fig 8 Timing Diagram

APPLICATION NOTE

The Example of Typical Application Circuit

Fig 9 is the example of typical application circuit. The red, yellow, and black wires are the input points of the motor system: red, the input of power supply; yellow, the output of FG; black, the ground signal. R_C is an external pull-up resistance for the use of measuring FG signal. In view of the design, the value of R_C could be decided by the transistor saturation voltage (V_{ON}), sink current (I_C), and off-level voltage (V_C).

The formula is:
$$R_C = \frac{V_C - V_{ON}}{I_C}$$

For example:

$V_C = +5V$ for TTL level.

$I_C = 10mA$ at 0.2V saturation voltage

The safety value of $R_C = 470$

D1 is the reverse protection diode. As if the red and black wires reversely connect with the power source, the current will flow through the ground via IC and coils L1 and L2 to power supply. Under such kind of circumstances, the IC and coils are easy to be burned out. Therefore, D1, the reverse protection diode, is necessary for the design. However, D1 will also cause an extra voltage drop on the supply voltage.

C1 is a capacitor to reduce the ripple noise caused during the transient of the output stages. The volume of the ripple noise depends on the coil impedance and characteristics.

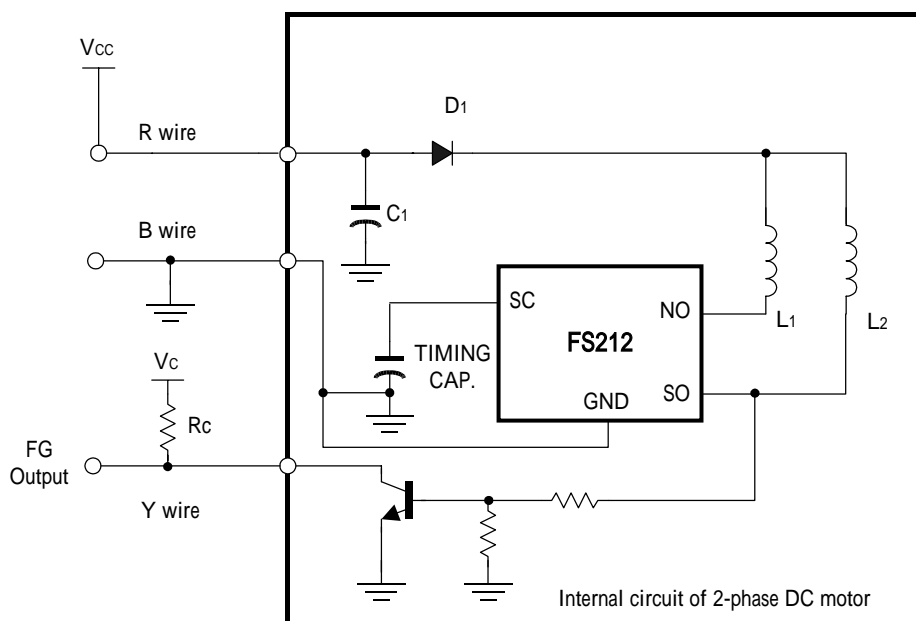
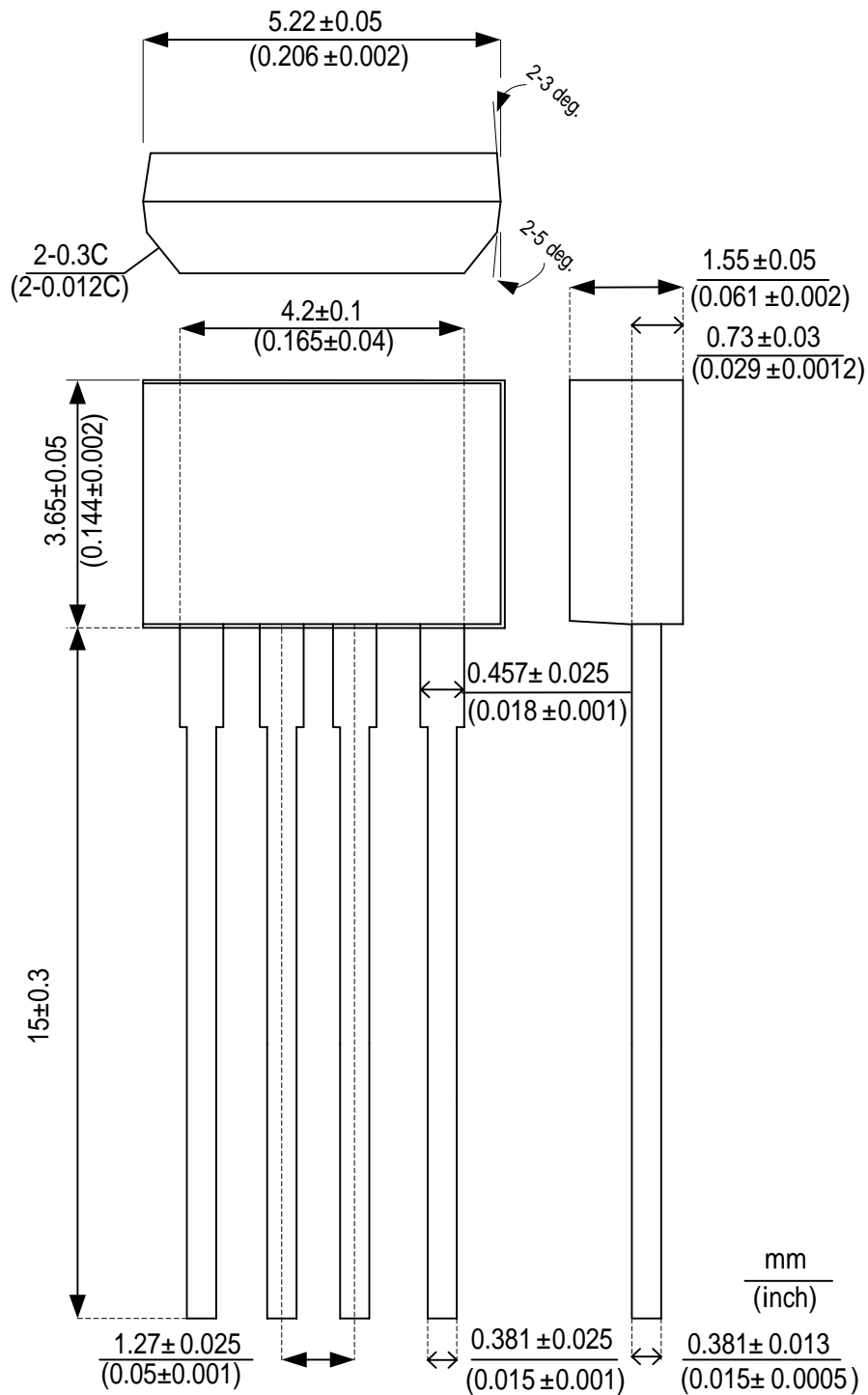

Fig 9 Application Circuit

PACKAGE OUTLINE



PACKING SPECIFICATIONS

BAG & BOX DIMENSION

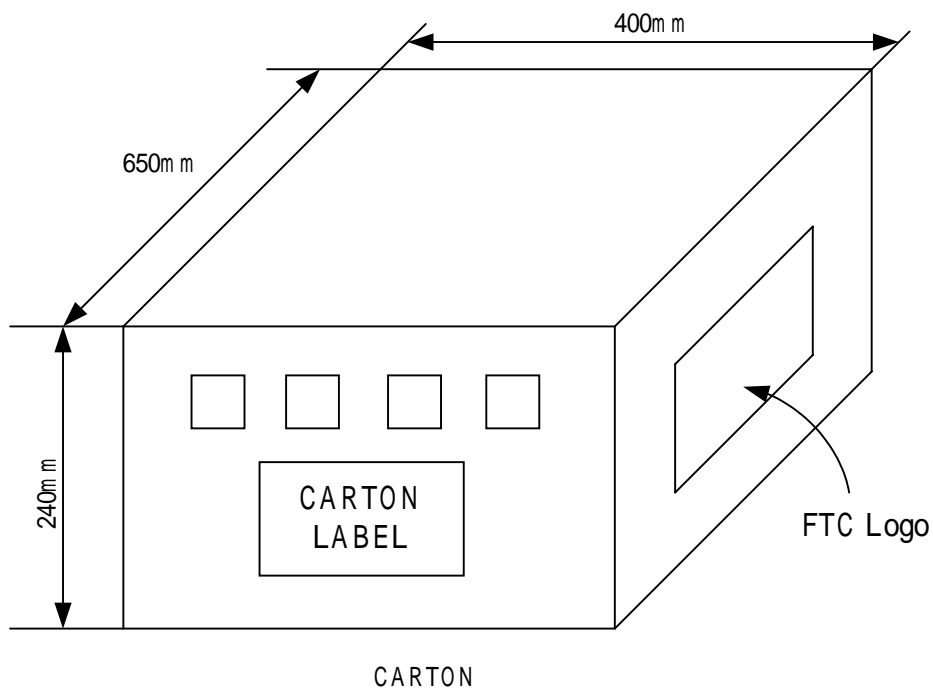
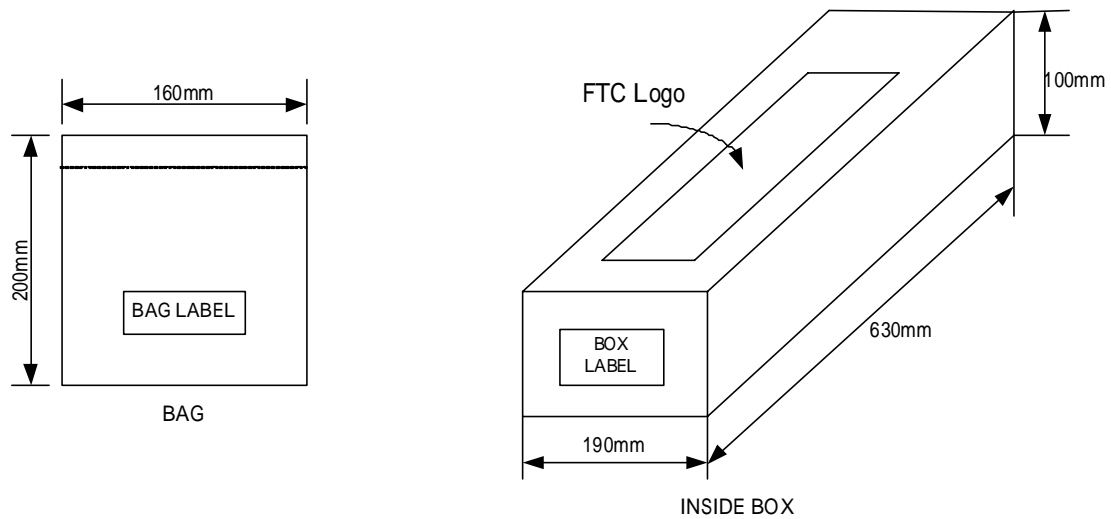

PACKING QUANTITY SPECIFICATIONS

1000 EA/1 BAG

25 BAGS/1 INSIDE BOX

4 INSIDE BOXES/1 CARTON

LABEL SPECIFICATIONS

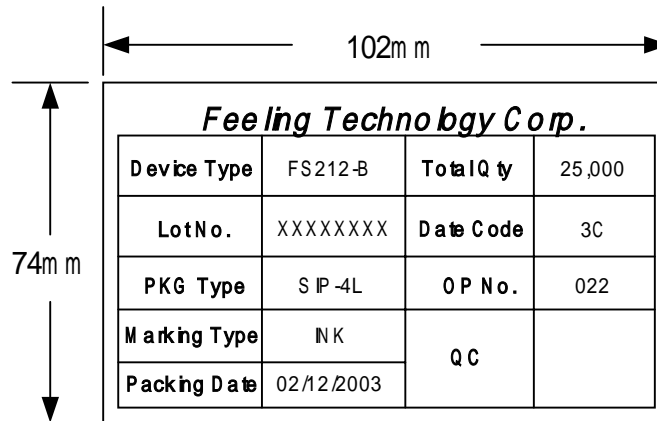
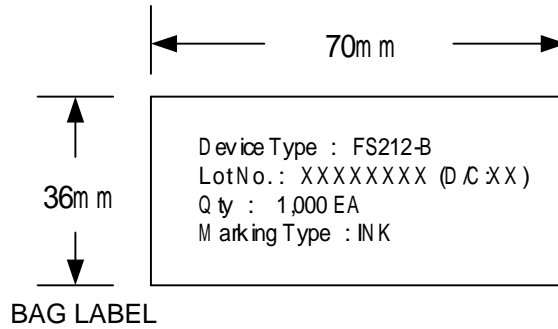

INSIDE BOX & CARTON LABEL

ORDER INFORMATION

Part Number	Operating Temperature	Package	Description
FS212-A	-20 ~ +85	TO-92SP-4	±60G (B)
FS212-B	-20 ~ +85	TO-92SP-4	±90G (B)