

## SINGLE PHASE DC MOTOR DRIVE IC

### GENERAL DESCRIPTION

The FS319, a 1-chip composed of hall sensor and output coil drivers, applied to a single-phase DC motor. The high sensitivity of Hall effect sensor is suitable for motors from mini-type CPU coolers to blowers and DC fans. Typical operation current is 0.3A and operating voltage range is wide.

Using few external components, FS319, a high performance integrated IC, is designed for a single-phase DC motor circuit. The circuit diagram of the typical application example is as below.

### FEATURES

- 1 chip hall sensor/drivers
- Wide operating voltage range: 3.0V~20V
- Output sink current up to 0.3A
- Output thermal-shutdown protect function
- Package : TO92-4L

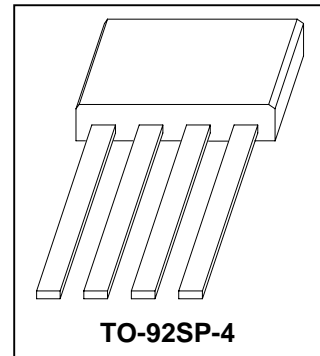

### TYPICAL APPLICATION CIRCUIT

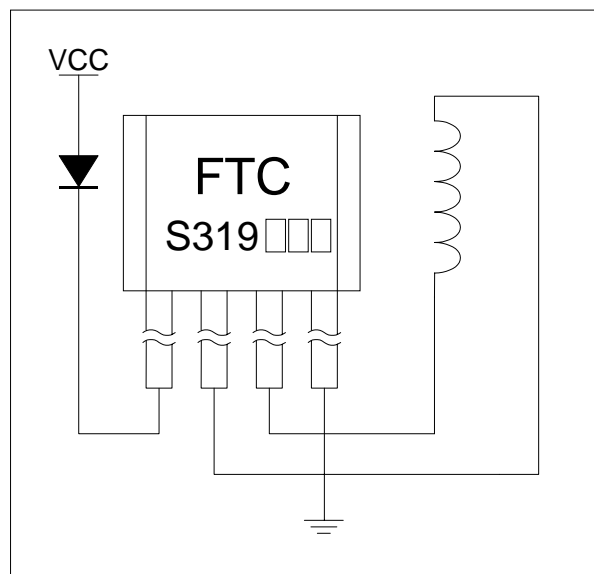

## FUNCTIONAL BLOCK DIAGRAM

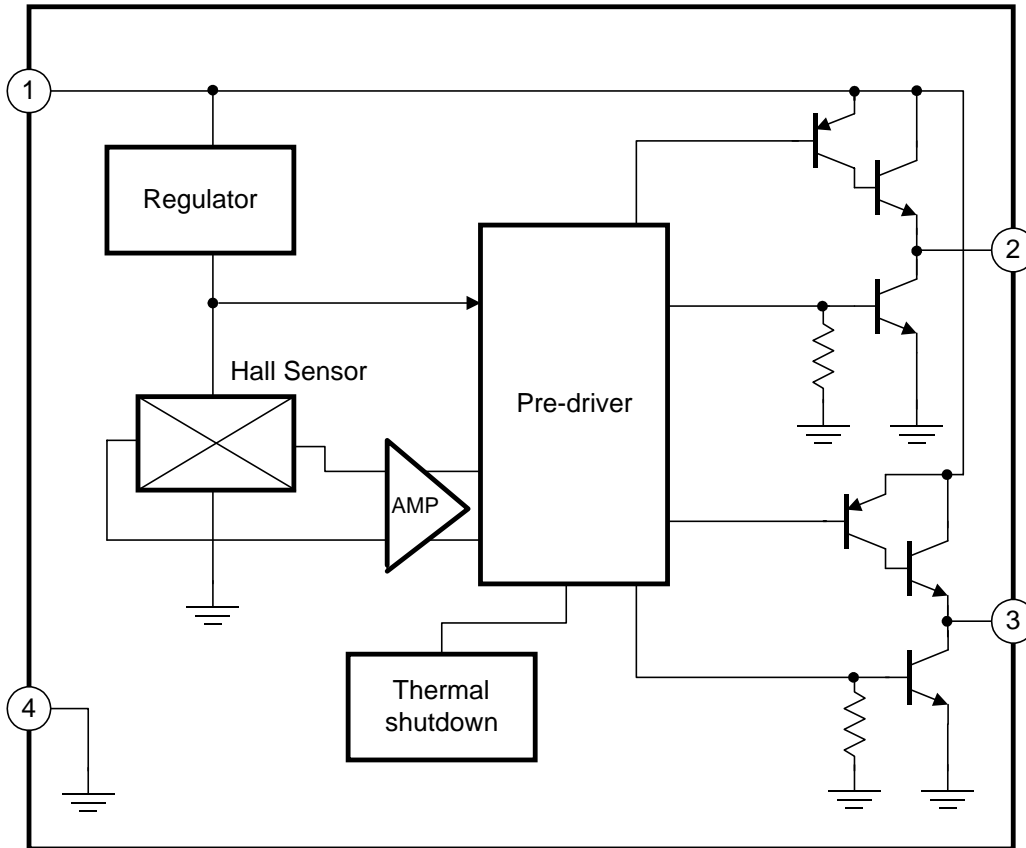

### MARK VIEW

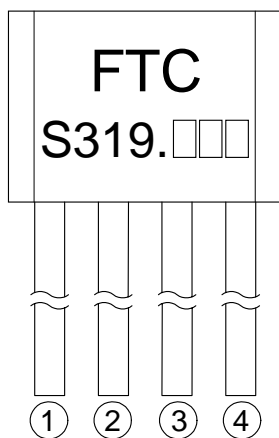

### PIN DESCRIPTION

NAME	NO.	STATUS	DESCRIPTION
VCC	1	P	IC Power Supply
NO	2	O	Coil driver output It is low state during the N magnetic field.
SO	3	O	Coil driver output It is low state during the S magnetic field.
GND	4	P	IC Ground

## ABSOLUTE MAXIMUM RATINGS

VCC Pin Voltage -----	20V
Output Peak Sink Current (Io)	
Peak Current -----	800mA
Hold Current -----	600mA
Continuous Current -----	300mA
Power Dissipation	
Ta=25°C -----	600mW
Ta=70°C -----	450mW
Silicon temperature up 150°C thermal shutdown function enable.	
Operating Temperature Range -----	0°C 85°C
Storage Temperature Range -----	-65°C 150°C
Junction Temperature -----	+150°C
Lead Temperature (Soldering, 10 sec) -----	+260°C

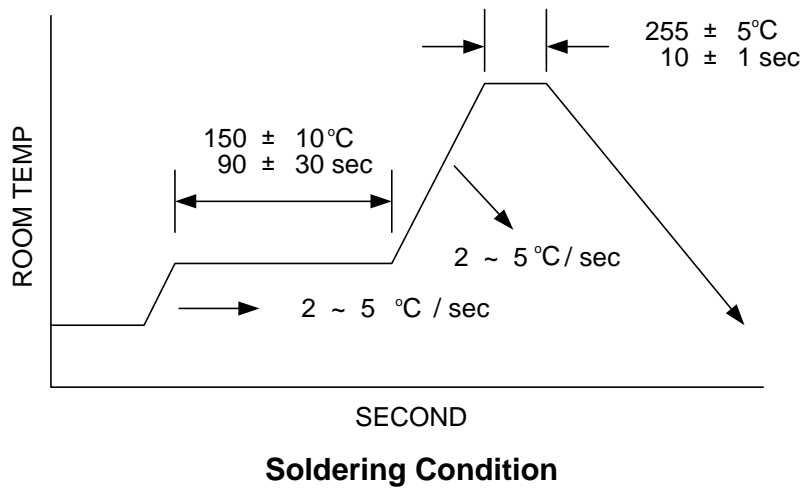

## DC ELECTRICAL CHARACTERISTICS

PARAMETER	SYMBOL	TEST CONDITIONS	MIN	TYP	MAX	UNIT
Supply Voltage	$V_{CC}$	-	3	—	20	V
Quiescent Supply current	$I_{CC}$	$V_{CC}=20V$ No use pin open (Fig1)	—	18	25	mA
Output Saturation Voltage	$V_{ce(sink)}$	$V_{CC}=14V, I_c = 200mA$	—	0.55	0.80	V
	$V_{ce(drive)}$	$V_{CC}=14V, I_c = 200mA$	$V_{CC}-1.5V$	—	$V_{CC}$	V
Note: Fig1 The IC output state is under N magnetic field.						

## AC ELECTRICAL CHARACTERISTICS

PARAMETER	SYMBOL	TEST CONDITIONS	MIN	TYP	MAX	UNIT
Rise time	$(t_r)$	$RL=820 \quad CL=20pF$ (Fig 2)		0.5	1.0	$\mu s$
Fall time	$(t_f)$	$RL=820 \quad CL=20pF$ (Fig 2)		0.5	1.5	$\mu s$

## MAGNETIC CHARACTERISTICS

FS319LF-A	Ta= 0 °C 85 °C		
PARAMETER	MIN	MAX	UNIT
Bop		+65	G
Brp	-65		G
Bhys		130	G

FS319LF-B	Ta= 0 °C 85 °C		
PARAMETER	MIN	MAX	UNIT
Bop		+80	G
Brp	-80		G
Bhys		160	G

FS319LF-C	Ta= 0 °C 85 °C		
PARAMETER	MIN	MAX	UNIT
Bop		+120	G
Brp	-120		G
Bhys		240	G

## FS319 HYSTERESIS CHARACTERISTICS

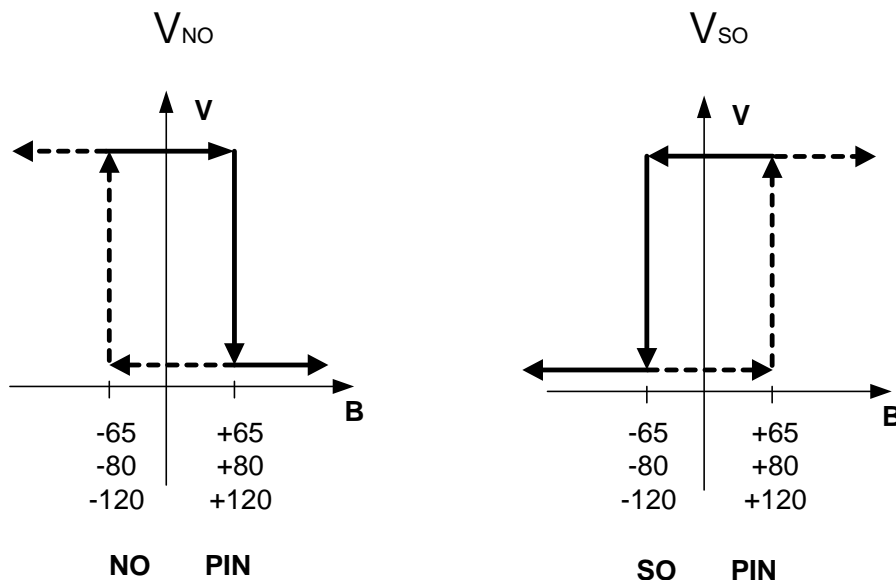

## TEST CIRCUITS

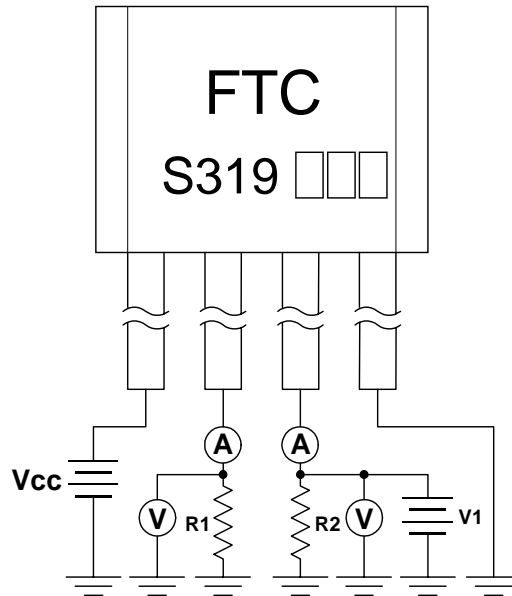

Fig 1. Test circuit

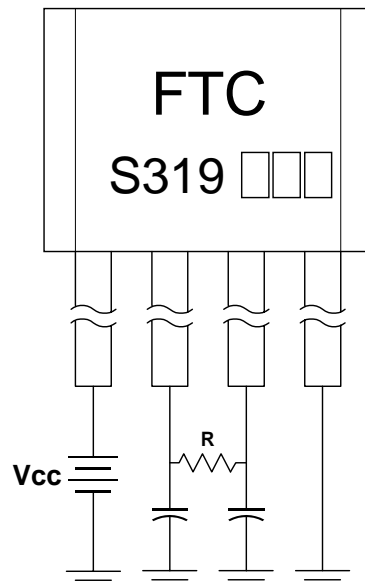

Fig 2. Test circuit

## TYPICAL CHARACTERISTICS

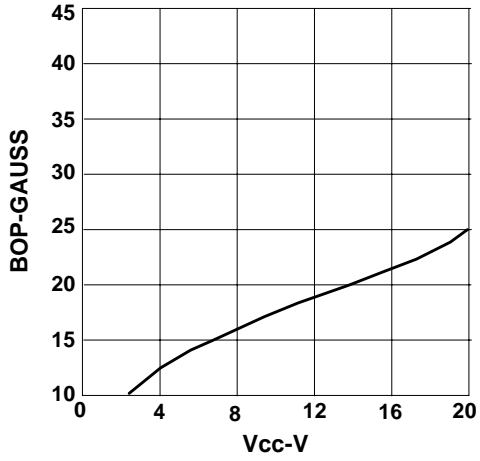

Figure 1

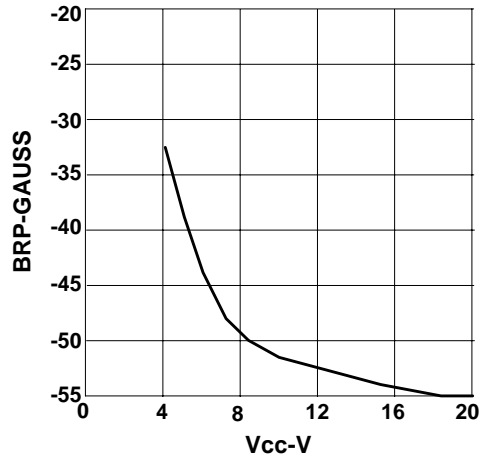

Figure 2

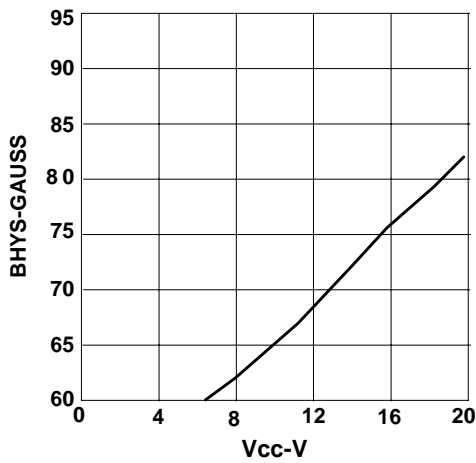

Figure 3

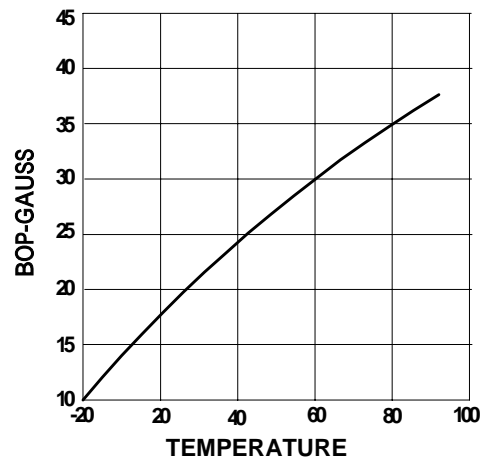

Figure 4

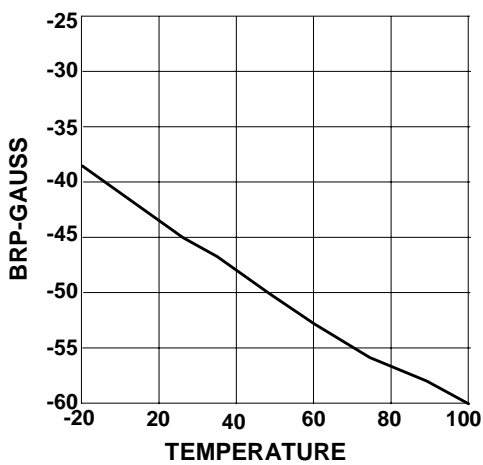

Figure 5

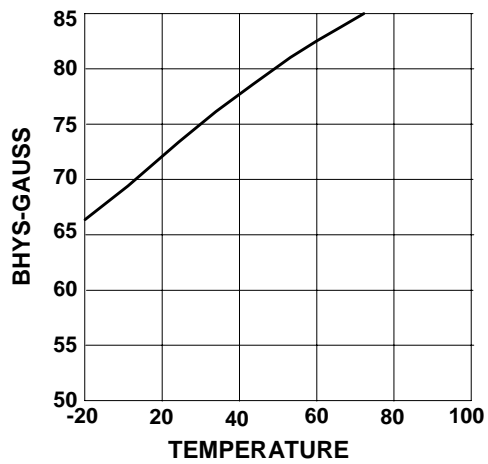

Figure 6

**FUNCTION DESCRIPTIONS**

**HALL SENSOR LOCATION**

The Fig 4 is the hall sensor location, where marks the IC number. The best sensitivity, which can be intensified as much as possible, depends on the vertical distance and position between magnetic pole and the hall sensor (Fig 5). For the single-phase motor, this design is very important.

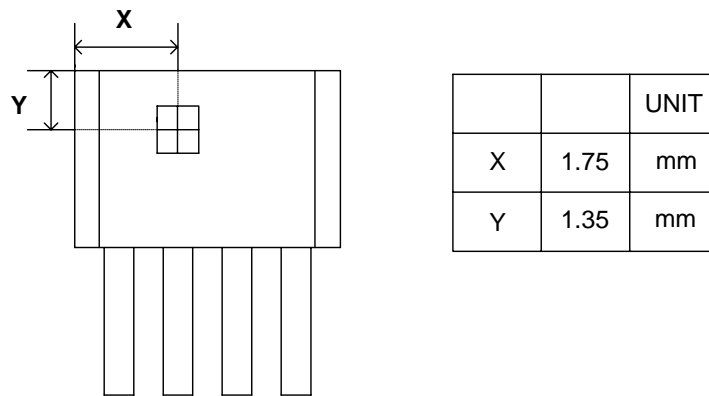

Fig 4 FS319 Hall Sensor Location

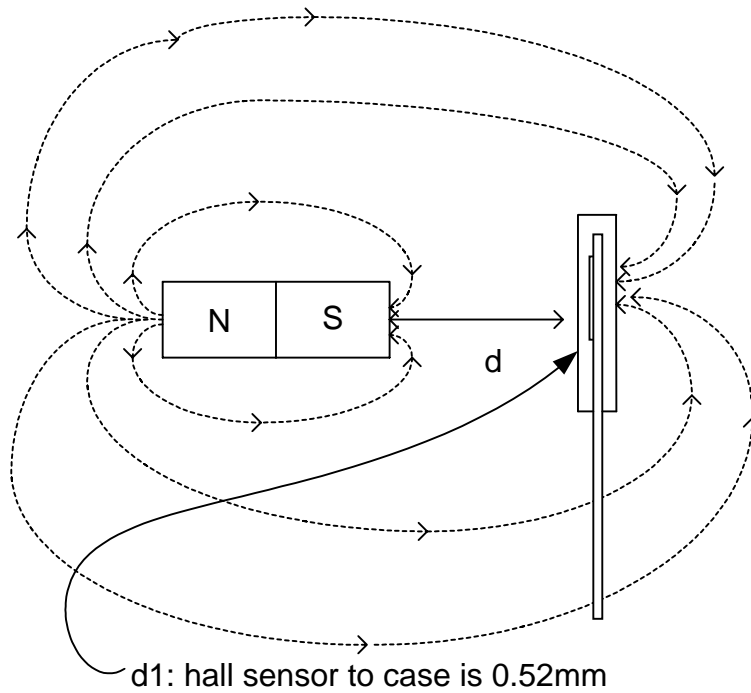

Fig 5 Magnetic Distribution and Z-axis position



**H-BRIDGE TRANSISTOR OUTPUT**

The Fig 6 is the circuit diagram of H-bridge transistors. The single-phase motor rotation depends on a switching current of coil L1. When the magnetic pole is N pole, Q2, Q3, Q5 is turn-off and Q1, Q4, Q6 is turn-on, L1 has a current from SO to NO. And when the magnetic pole is S pole, Q1, Q4, Q6 is turn-off and Q2, Q3 is turn-on, L1 has a current from NO to SO.

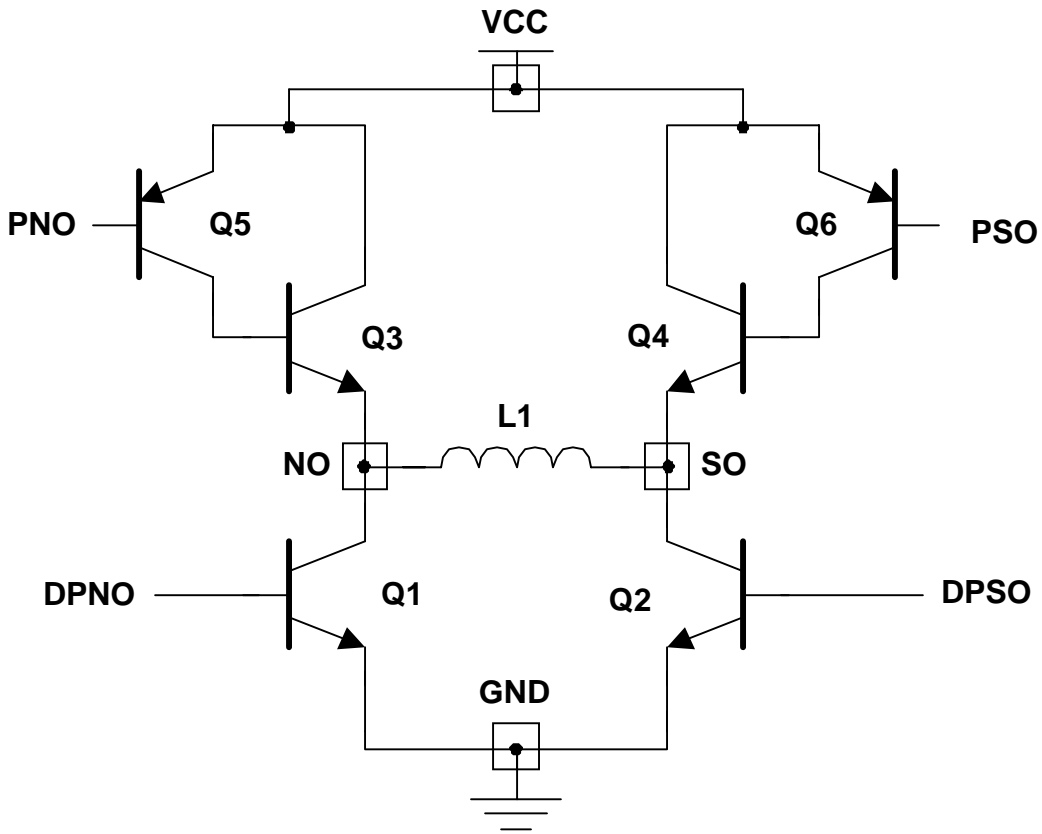

Fig 6 H-Bridge Transistors Output

## APPLICATION NOTE

### The Example of Typical Application Circuit

Fig 7 is the example of typical application circuit. The red, yellow, and black wires are the input points of the motor system: red, the input of power supply; yellow, the output of FG; black, the ground signal.  $R_C$  is an external pull-up resistance for the use of measuring FG signal. In view of the design, the value of  $R_C$  could be decided by the transistor saturation voltage ( $V_{ON}$ ), sink current ( $I_C$ ), and off-level voltage ( $V_C$ ).

The formula is: 
$$R_C = \frac{V_C - V_{ON}}{I_C}$$

For example:

$V_C = +5V$  for TTL level.

$I_C = 10mA$  at 0.2V saturation voltage

The safety value of  $R_C = 470$

D1 is the reverse protection diode. As if the red and black wires reversely connect with the power source, the current will flow through the ground via IC and coils L1 and L2 to power supply. Under such kind of circumstances, the IC and coils are easy to be burned out. Therefore, D1, the reverse protection diode, is necessary for the design. However, D1 will also cause an extra voltage drop on the supply voltage.

C1 is a capacitor to reduce the ripple noise caused during the transient of the output stages. The volume of the ripple noise depends on the coil impedance and characteristics.

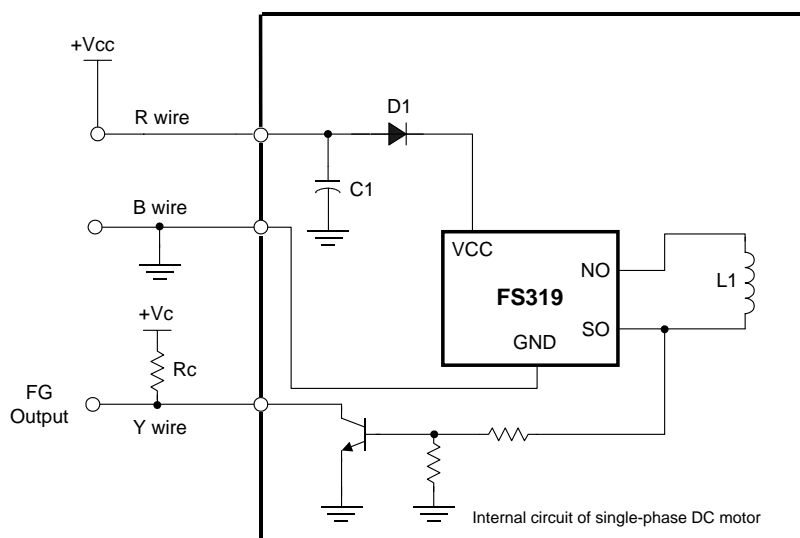
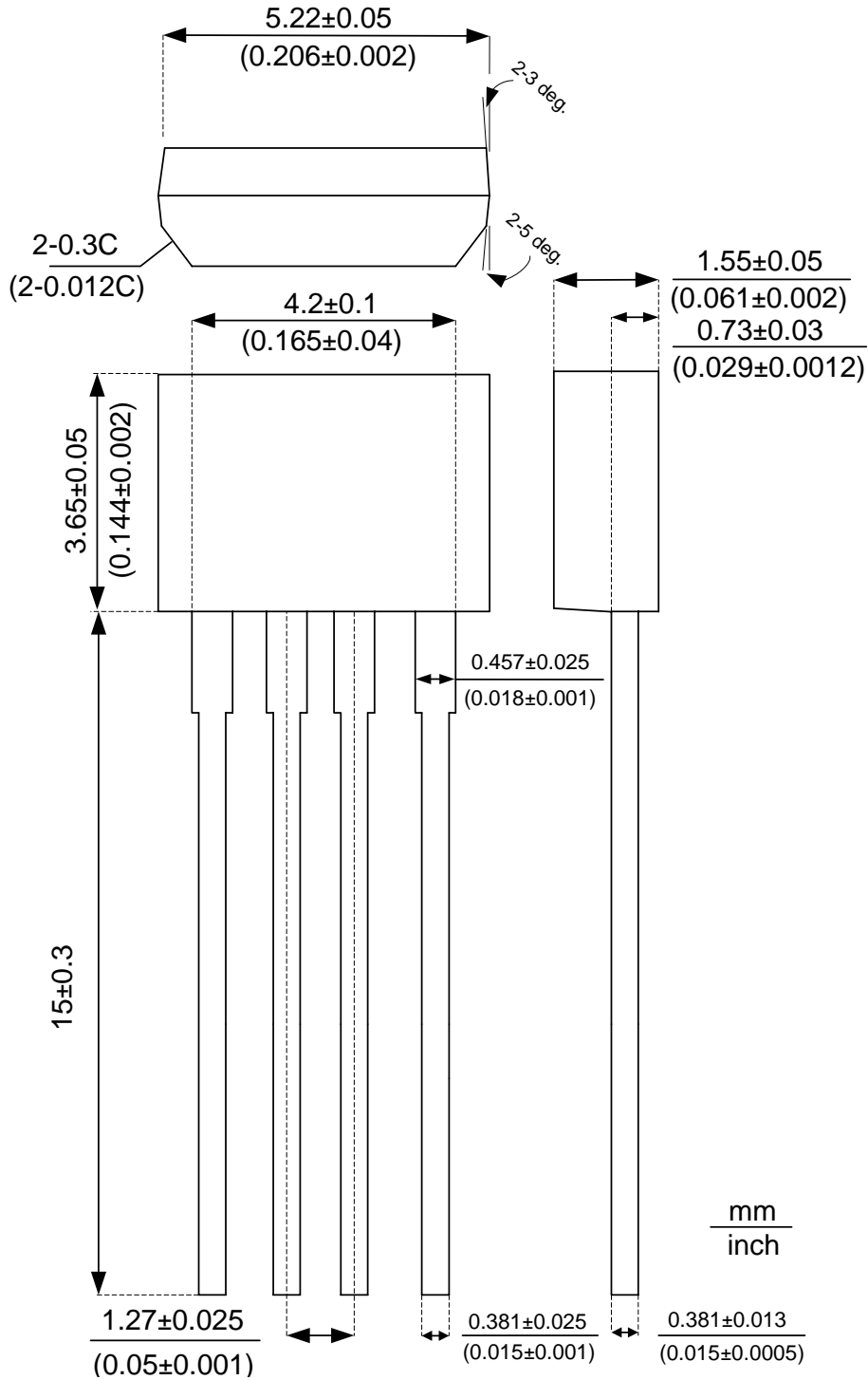

Fig 7 Application Circuit

## PACKAGE OUTLINE (LEAD FREE)



## PACKING SPECIFICATIONS

### BAG & BOX DIMENSION

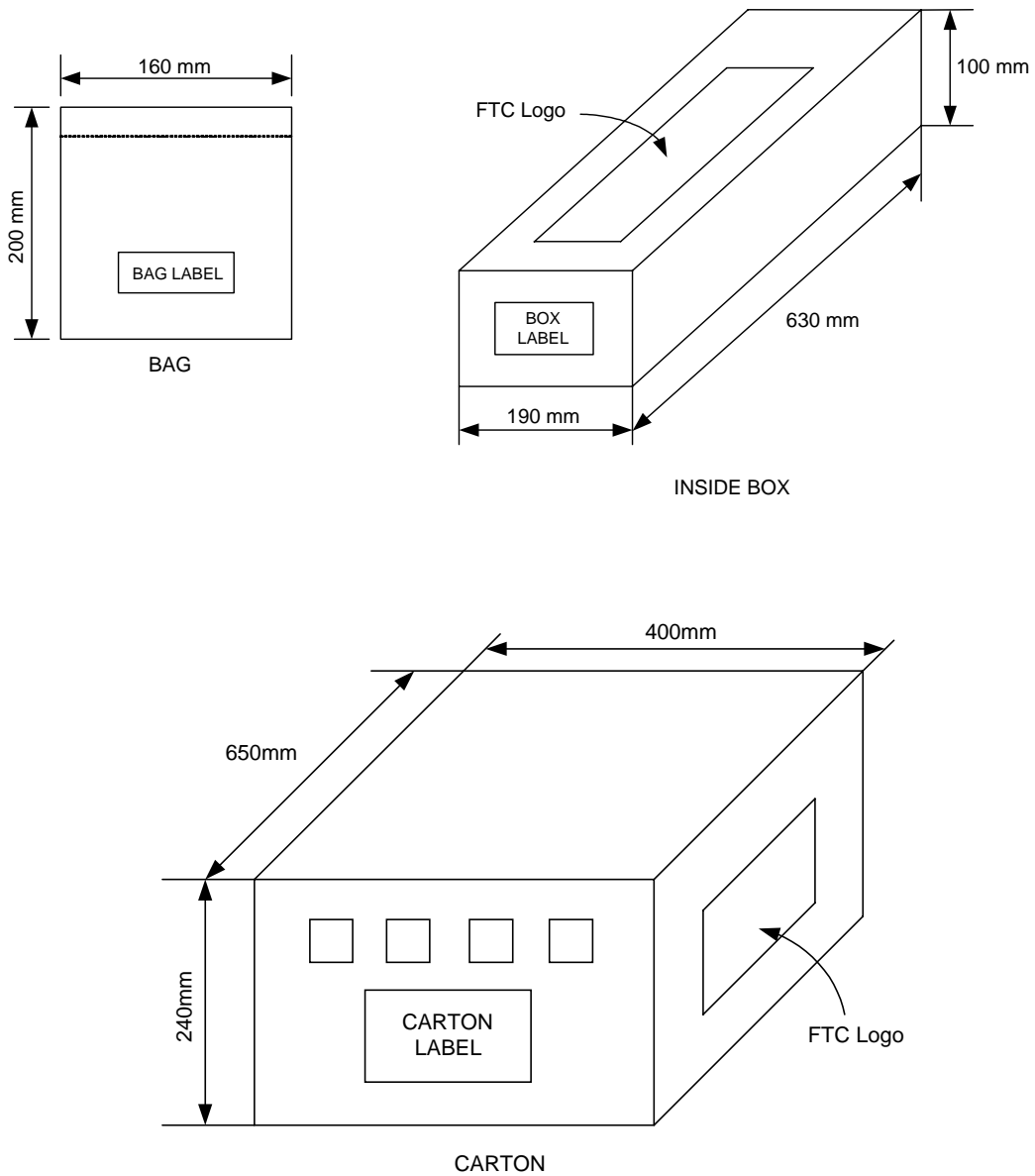

## PACKING QUANTITY SPECIFICATIONS

1000 EA /1 BAG

25 BAGS /1 INSIDE BOX

4 INSIDE BOXES /1 CARTON

## LABEL SPECIFICATIONS

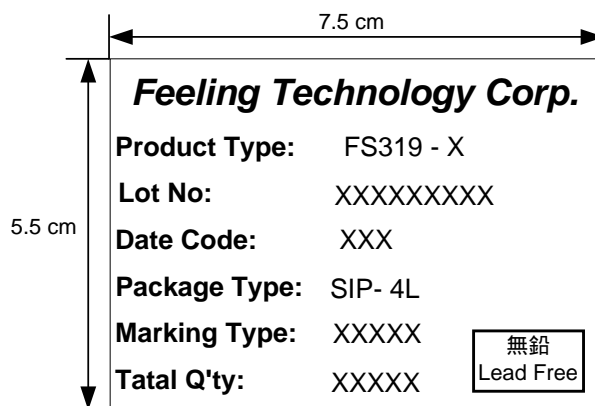

BAG LABEL, INSIDE BOX & CARTON LABEL

## ORDER INFORMATION

Part Number	Operating Temperature	Package	Description
FS319LF-A	0°C +85 °C	TO-92SP-4	±65G (B)
FS319LF-B	0°C +85 °C	TO-92SP-4	±80G (B)
FS319LF-C	0°C +85 °C	TO-92SP-4	±120G (B)