

## Single Hall Effect Latch

### Features

- Wide operating voltage range: 3.0V to 28V
- Maximum output sink current 50mA
- Open-Collector pre-driver
- Power reverse polarity protection
- Available in SIP-3L package

 Halogen Free

### General Description

The FS1102 is an integrated Hall effect latched sensor designed for electronic commutation of brush-less DC motor applications. The device includes an on-chip Hall voltage generator for magnetic sensing, a comparator that amplifies the Hall voltage, and a Schmitt trigger to provide switching hysteresis for noise rejection, and open-collector output. An internal bandgap regulator is used to provide temperature compensated supply voltage for internal circuits and allows a wide operating supply range.

A north pole of sufficient strength will turn the output ON. In the absence of a magnetic field, the output is OFF.

### Block Diagram

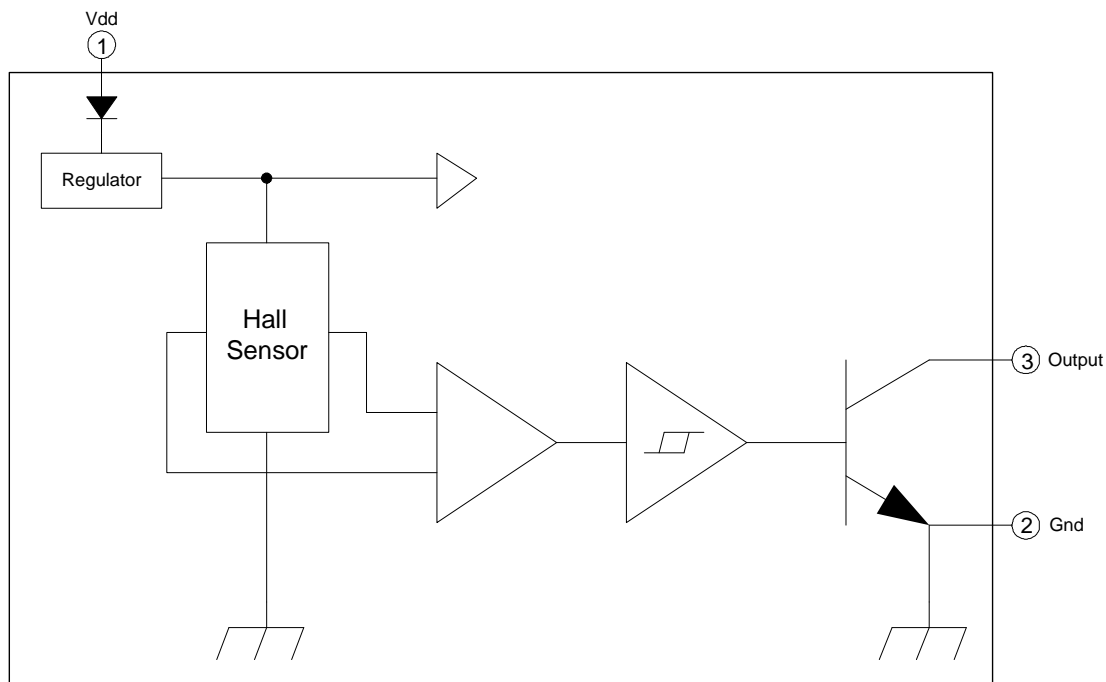
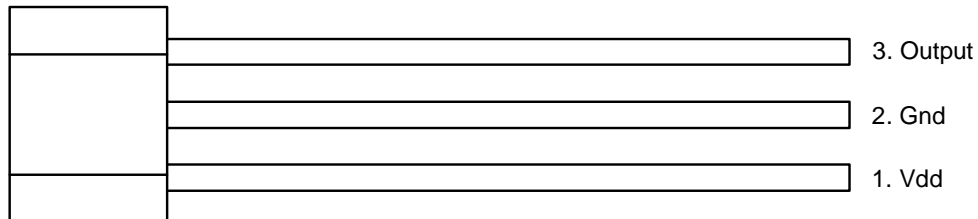

Figure.1

**Pin Connection**

[Top View]

**Figure.2**
**Pin Descriptions**

Name	I/O	Pin No.	Description
Vdd	P	1	Positive power supply
Gnd	G	2	Ground
Output	O	3	Driver output

Legend: I=input, O=output, I/O=input/output, P=power supply, G=ground

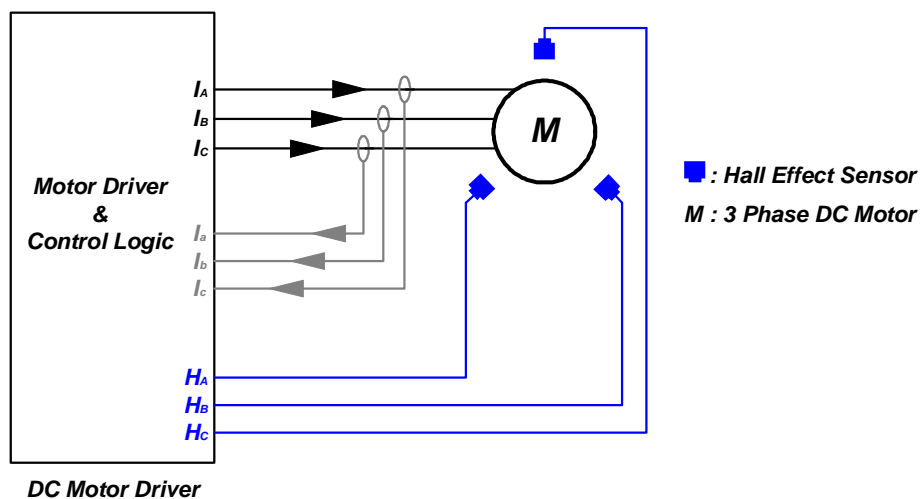
**Functional Application Circuit**

**Figure.3**



### Absolute Maximum Ratings

Parameter	Symbol	Conditions	Values			Unit
			Min.	Typ.	Max.	
Operating Temperature	T <sub>OP</sub>	-	-40		150	°C
Storage Temperature	T <sub>ST</sub>	-	-65		150	°C
DC Supply Voltage	V <sub>DD</sub>	-	3.0		28	V
Supply Current	I <sub>DD</sub>	-			10	mA
Continuous Current	I <sub>O(CONT)</sub>				50	mA
Junction temperature	T <sub>J</sub>				160	°C
Power Dissipation	P <sub>D</sub>	SIP-3L			500	mW
Thermal Resistance	θ <sub>JC</sub>	SIP-3L		0.27		°C/mW
Lead Temperature		10sec			260	°C

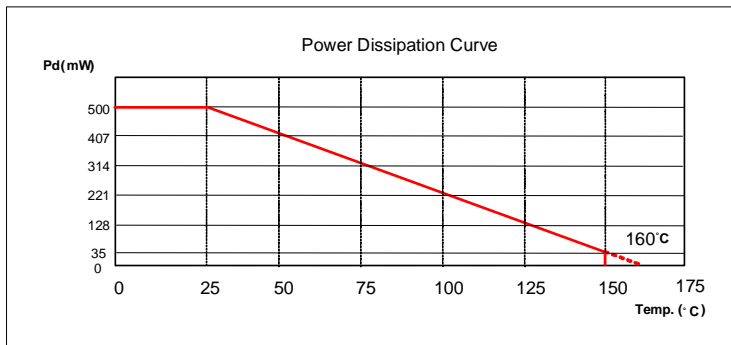

Figure.4

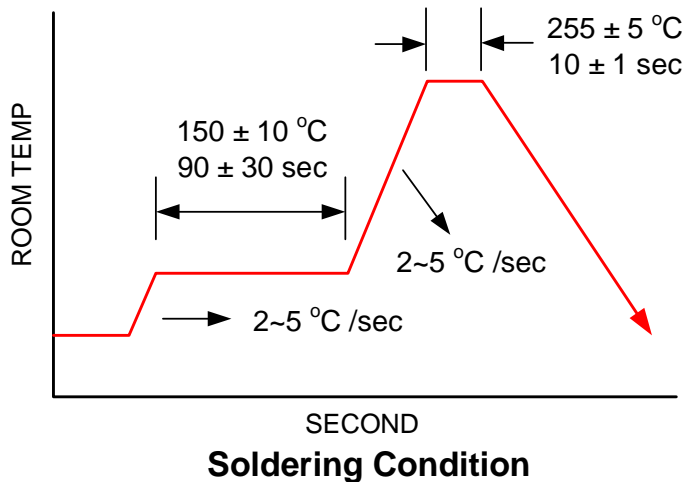

Figure.5

**Recommended Operating Conditions**

Parameter	Symbol	Conditions	Values			Unit
			Min.	Typ.	Max.	
Supply Voltage	$V_{DD}$	-	3.0		28	V
Operating Temperature Range	$T_A$	-	-40		150	°C

**Electrical Characteristics  $V_{DD}=12.0V$ ,  $T_A=25^\circ C$**  (unless otherwise specified)

Parameter	Symbol	Conditions	Values			Unit
			Min.	Typ.	Max.	
Average Supply Current(no load)	$I_{DD}$	-		3.5	10	mA
Output Saturation Voltage	$V_{SAT}$	$I_{out}= 20mA$		165	200	mV
Output Rise time	$t_r$	$R_L=500\Omega$ , $C_L=20pF$ (Figure 7)	0.2	-	0.75	$\mu s$
Output Fall time	$t_f$	$R_L=500\Omega$ , $C_L=20pF$ (Figure 7)	20	-	150	ns

**Magnetic Characteristics**

Parameter	Symbol	Conditions	Values			Unit
			Min.	Typ.	Max.	
Operate Points	$B_{OP}$		+140	-	-	G
Release Points	$B_{RP}$		-	-	+60	G
Hysteresis	$B_{HYST}$		30	-	120	G

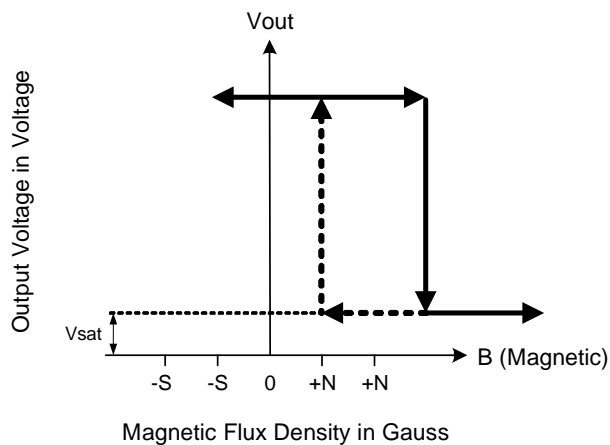
**Hysteresis Characteristics**

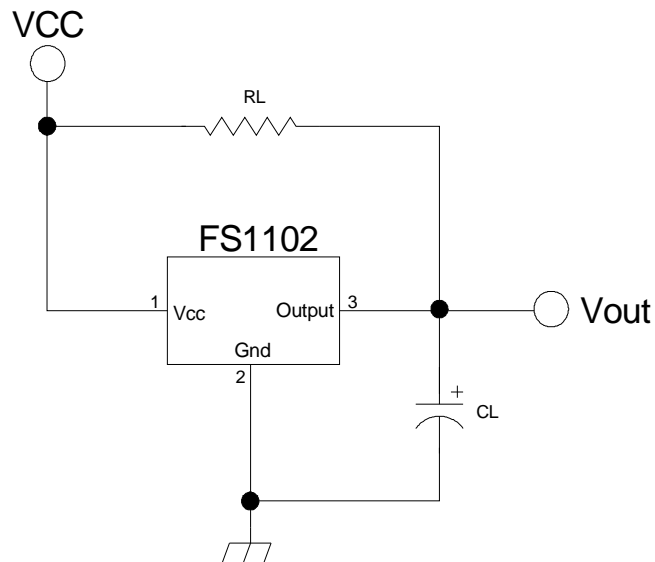
**Figure.6**

**Test Circuit**

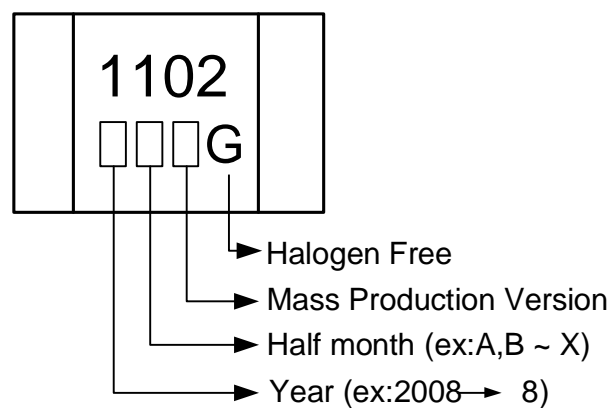
**Figure.7**
**Marking Information**

[Top View]

**Figure.8**

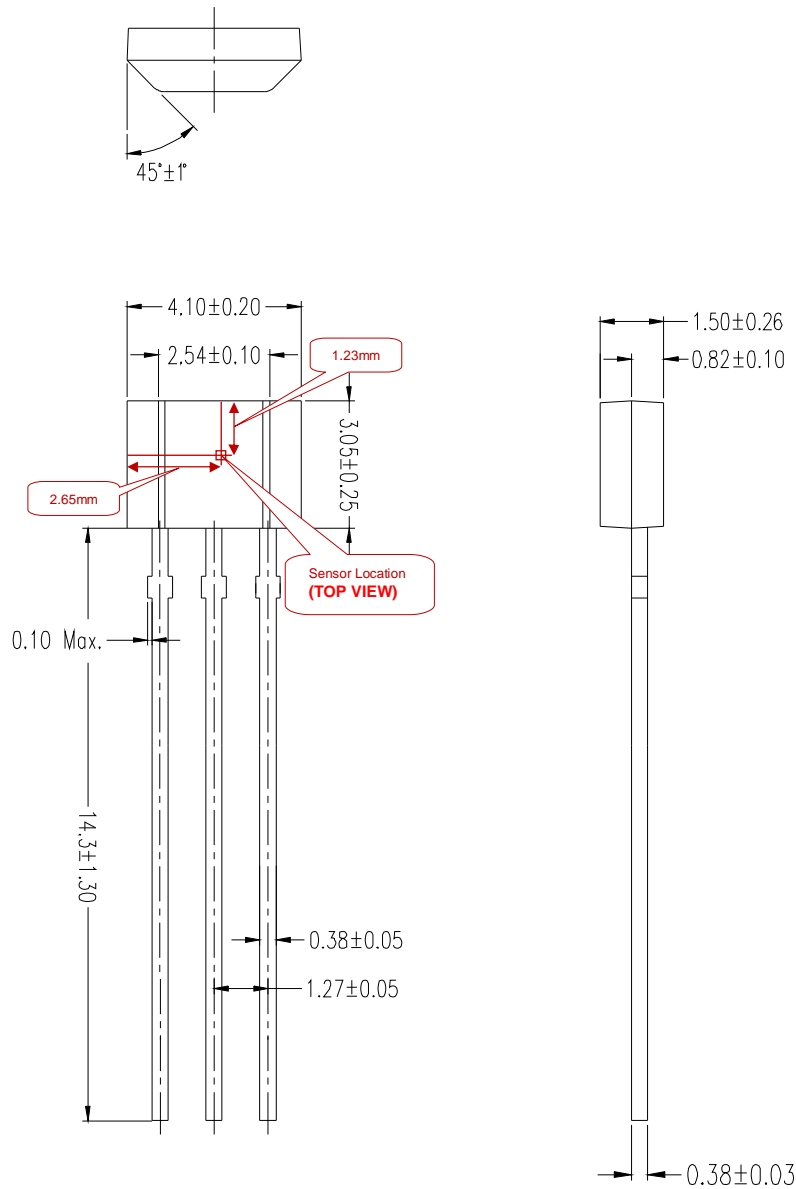

**Package Dimension (Unit: mm)**  
**SIP-3L(Halogen Free)**



**Order Information**

Part Number	Operating Temperature	Package	MOQ
FS1102G1	-40 °C to +150 °C	SIP-3L	1000ea