



# SPN60T15

## N-Channel Enhancement Mode MOSFET

### DESCRIPTION

The SPN60T15 is the N-Channel enhancement mode power field effect transistor which is produced using super high cell density DMOS trench technology. This high density process is especially tailored to minimize on-state resistance. These devices are particularly suitable for synchronous rectifier application, Motor control power management and other Power Tool circuits. It has been optimized for low gate charge, low  $R_{DS(ON)}$  and fast switching speed.

### FEATURES

- ◆ 150V/60A,  $R_{DS(ON)}=19m\Omega@V_{GS}=10V$
- ◆ High density cell design for extremely low  $R_{DS(ON)}$
- ◆ Exceptional on-resistance and maximum DC current capability
- ◆ TO-220-3L/TO-220F-3L/PPAK5x6-8L package design

### APPLICATIONS

- AC/DC Synchronous Rectifier
- Load Switch
- UPS
- Power Tool
- Motor Control

### PIN CONFIGURATION

TO-220

TO-220F

PPAK5x6

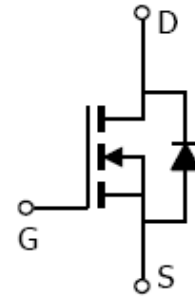
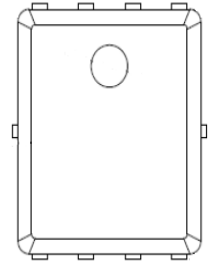
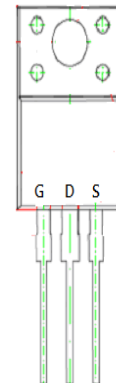
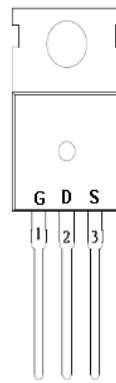

### PART MARKING



A : Lot Code  
B : Date Code  
(YY/MM/DD)

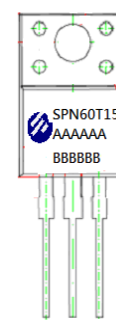

A: Lot Code  
B: Date Code  
(YYMMDD)

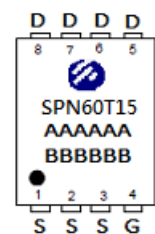

A : Lot Code  
B : Date Code  
(YY/MM/DD)



# SPN60T15

## N-Channel Enhancement Mode MOSFET

### TO-220/TO-220F PIN DESCRIPTION

Pin	Symbol	Description
1	G	Gate
2	D	Drain
3	S	Source

### PPAK5x6 PIN DESCRIPTION

Pin	Symbol	Description
1	S	Source
2	S	Source
3	S	Source
4	G	Gate
5	D	Drain
6	D	Drain
7	D	Drain
8	D	Drain

### ORDERING INFORMATION

Part Number	Package	Part Marking
SPN60T15T220TGB	TO-220-3L	SPN60T15
SPN60T15T220FTGB	TO-220F-3L	SPN60T15
SPN60T15DN8RGB	PPAK5x6-8L	SPN60T15

- ※ SPN60T15T220TGB : Tube ; Pb – Free ; Halogen – Free
- ※ SPN60T15T220FTGB : Tube ; Pb – Free ; Halogen - Free
- ※ SPN60T15DN8RGB : Tape&Reel ; Pb – Free ; Halogen - Free



# SPN60T15

## N-Channel Enhancement Mode MOSFET

### ABSOLUTE MAXIMUM RATINGS

(T<sub>j</sub>=25°C Unless otherwise noted)

Parameter	Symbol	Typical	Unit	
Drain-Source Voltage	V <sub>DSS</sub>	150	V	
Gate –Source Voltage	V <sub>GSS</sub>	±20	V	
Continuous Drain Current(Silicon Limited) TO-220/TO-220F	I <sub>D</sub>	T <sub>C</sub> =25°C	69	A
		T <sub>C</sub> =100°C	49	
Continuous Drain Current(Silicon Limited) PPAK5x6	I <sub>D</sub>	T <sub>C</sub> =25°C	60	A
		T <sub>C</sub> =100°C	38	
Pulsed Drain Current(TO-220/TO-220F)	I <sub>DM</sub>	150	A	
Pulsed Drain Current(PPAK5x6)		120		
Avalanche Energy, Single Pulse @ L=0.3mH, T <sub>C</sub> =25°C	E <sub>AS</sub>	184	mJ	
Power Dissipation @ T <sub>C</sub> =25°C (TO-220/TO-220F)	P <sub>D</sub>	214	W	
Power Dissipation @ T <sub>C</sub> =25°C (PPAK5x6)		125		
Operating Junction Temperature(TO-220/TO-220F)	T <sub>J</sub>	-55/150	°C	
Storage Temperature Range(TO-220/TO-220F)	T <sub>STG</sub>	-55/150	°C	
Operating Junction Temperature(PPAK5x6)	T <sub>J</sub>	-55/150	°C	
Storage Temperature Range(PPAK5x6)	T <sub>STG</sub>	-55/150	°C	
Thermal Resistance-Junction to Ambient (TO-220/TO-220F)	R <sub>θJA</sub>	60	°C/W	
Thermal Resistance-Junction to Ambient (PPAK5x6)	R <sub>θJA</sub>	50	°C/W	
Thermal Resistance-Junction to Case (TO-220/TO-220F)	R <sub>θJC</sub>	0.7	°C/W	
Thermal Resistance-Junction to Case (PPAK5x6)	R <sub>θJC</sub>	1	°C/W	



# SPN60T15

## N-Channel Enhancement Mode MOSFET

### ELECTRICAL CHARACTERISTICS

(TA=25°C Unless otherwise noted)

Parameter	Symbol	Conditions	Min.	Typ	Max.	Unit
<b>Static</b>						
Drain-Source Breakdown Voltage	$V_{(BR)DSS}$	$V_{GS}=0V, I_D=250\mu A$	150			V
Gate Threshold Voltage	$V_{GS(th)}$	$V_{DS}=V_{GS}, I_D=250\mu A$	2.0	3.0	4.0	V
Gate Leakage Current	$I_{GSS}$	$V_{DS}=0V, V_{GS}=\pm 20V$			$\pm 100$	nA
Zero Gate Voltage Drain Current	$I_{DSS}$	$V_{DS}=150V, V_{GS}=0V$ $T_J=25^\circ C$			1	uA
		$V_{DS}=150V, V_{GS}=0V$ $T_J=100^\circ C$			100	
Drain-Source On-Resistance	$R_{DS(on)}$	$V_{GS}=10V, I_D=20A$		15	19	mΩ
Forward Transconductance	$g_{fs}$	$V_{DS}=5V, I_D=20A$		50		S
Gate Resistance	$R_G$	$V_{GS}=0V, V_{DS}=\text{Open},$ $f=1\text{MHz}$		3.5		Ω
Diode Forward Voltage	$V_{SD}$	$I_S=20A, V_{GS}=0V$		0.9	1.2	V
<b>Dynamic</b>						
Total Gate Charge	$Q_g$	$V_{DS}=75V, V_{GS}=10V$ $I_D=20A$		27		nC
Gate-Source Charge	$Q_{gs}$			9		
Gate-Drain Charge	$Q_{gd}$			2		
Input Capacitance	$C_{iss}$	$V_{DS}=75V, V_{GS}=0V$ $f=1\text{MHz}$		2275		pF
Output Capacitance	$C_{oss}$			165		
Reverse Transfer Capacitance	$C_{rss}$			5.5		
Turn-On Time	$t_{d(on)}$	$V_{DD}=75V, V_{GS}=10V$ $I_D=20A, R_G=10\Omega$		12		nS
	$t_r$			4		
Turn-Off Time	$t_{d(off)}$			24		
	$t_f$			5		



# SPN60T15

## N-Channel Enhancement Mode MOSFET

### TYPICAL CHARACTERISTICS

Fig 1. Typical Output Characteristics

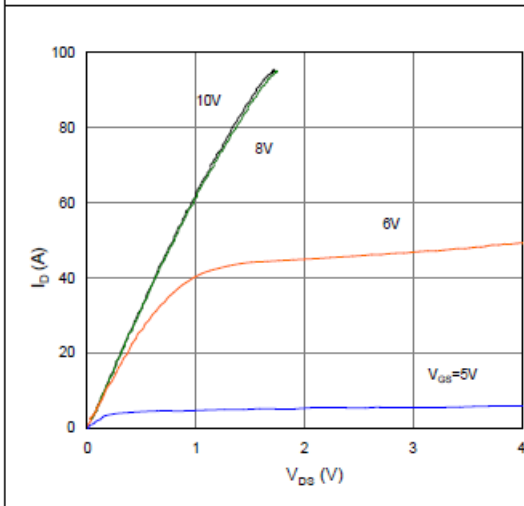

Figure 2. On-Resistance vs. Gate-Source Voltage

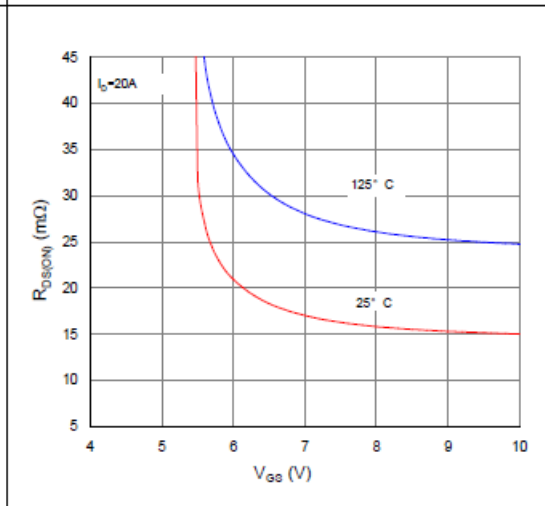

Figure 3. On-Resistance vs. Drain Current and Gate Voltage

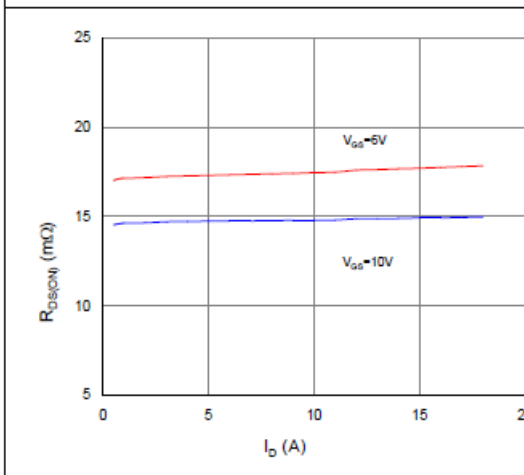

Figure 4. Normalized On-Resistance vs. Junction Temperature

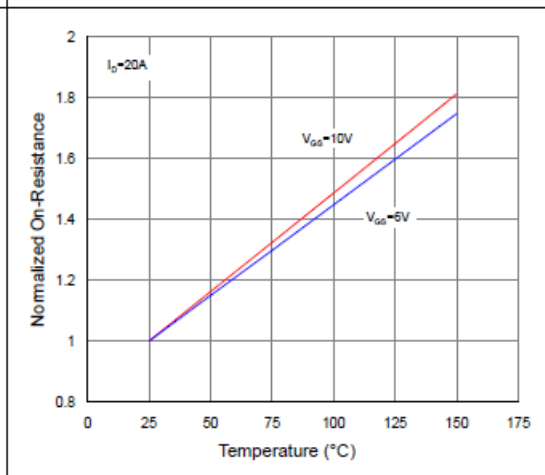

Figure 5. Typical Transfer Characteristics

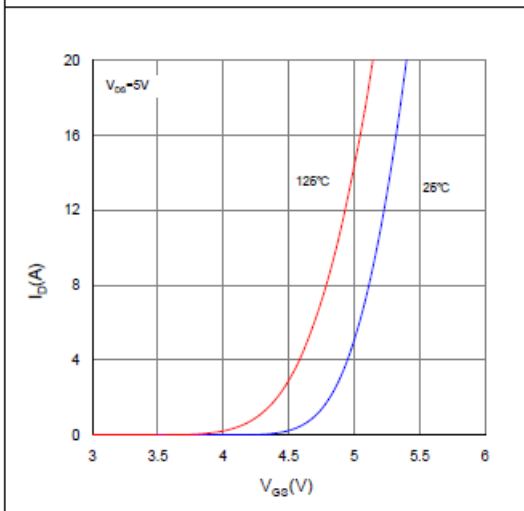
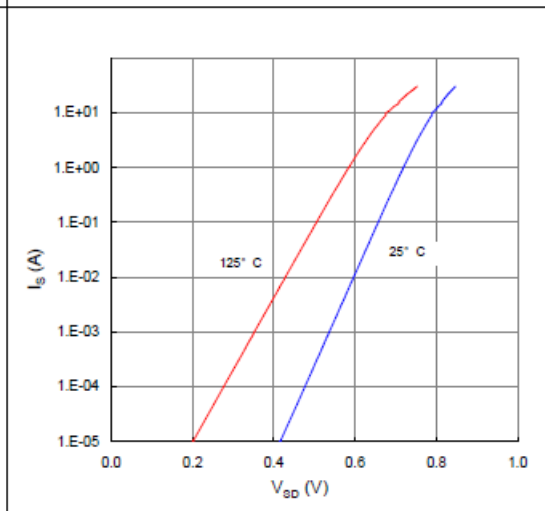

Figure 6. Typical Source-Drain Diode Forward Voltage





# SPN60T15

## N-Channel Enhancement Mode MOSFET

### TYPICAL CHARACTERISTICS

Figure 7. Typical Gate-Charge vs. Gate-to-Source Voltage

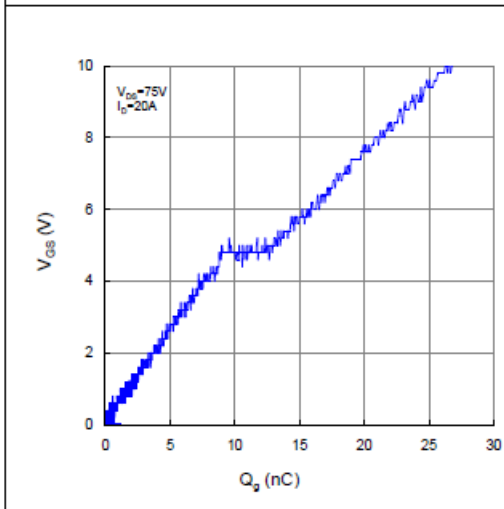

Figure 8. Typical Capacitance vs. Drain-to-Source Voltage

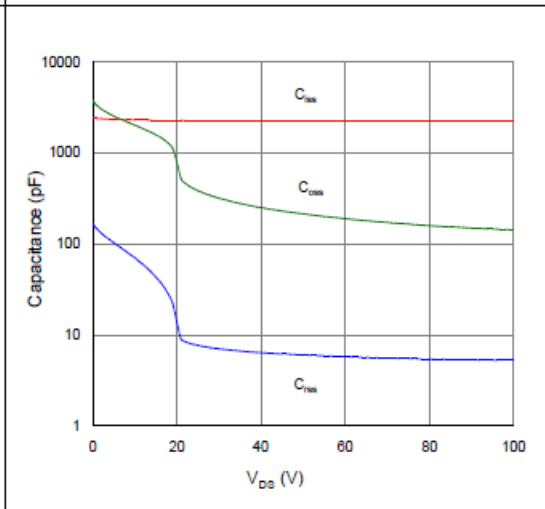

Figure 9. Maximum Safe Operating Area

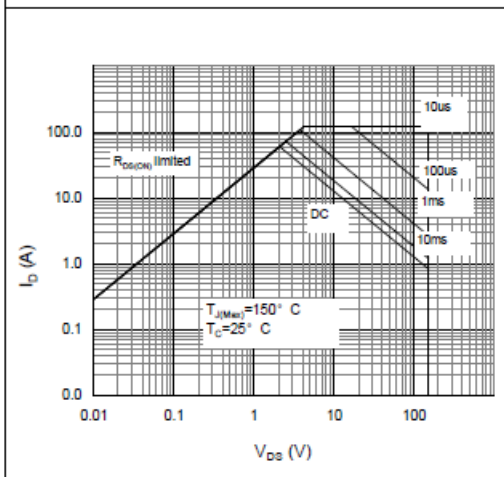

Figure 10. Maximum Drain Current vs. Case Temperature

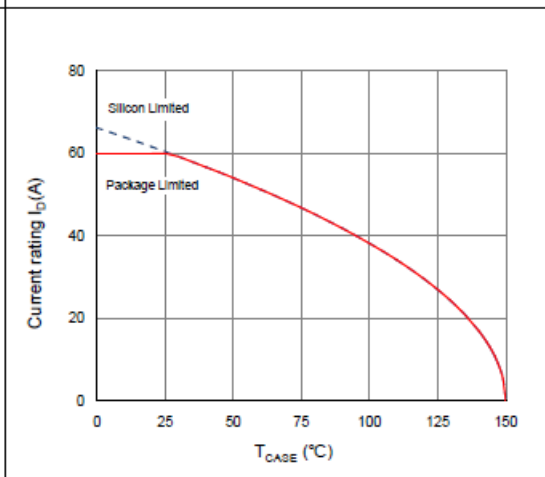
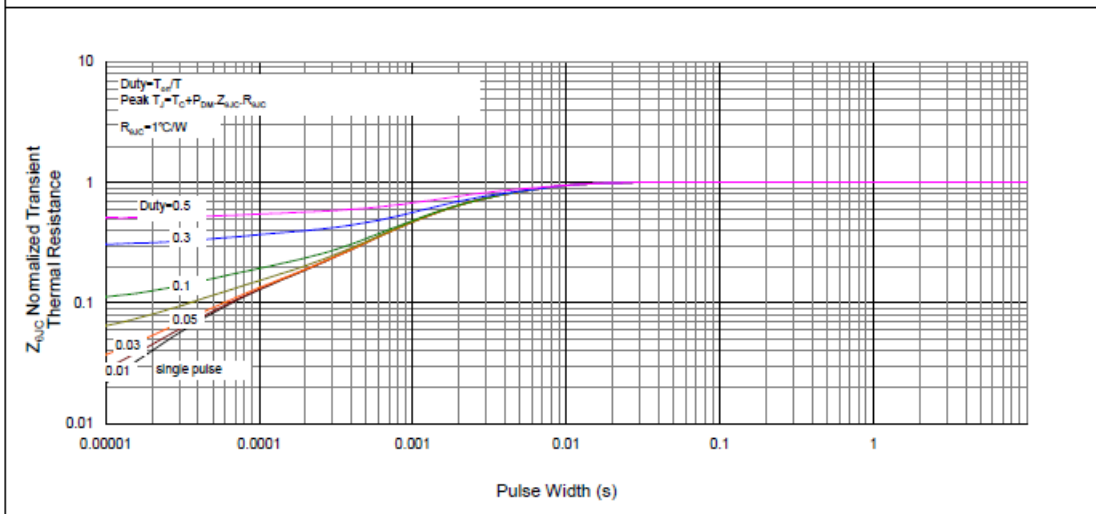

Figure 11. Normalized Maximum Transient Thermal Impedance, Junction-to-Case





# SPN60T15

## N-Channel Enhancement Mode MOSFET

### TO-220-3L PACKAGE OUTLINE

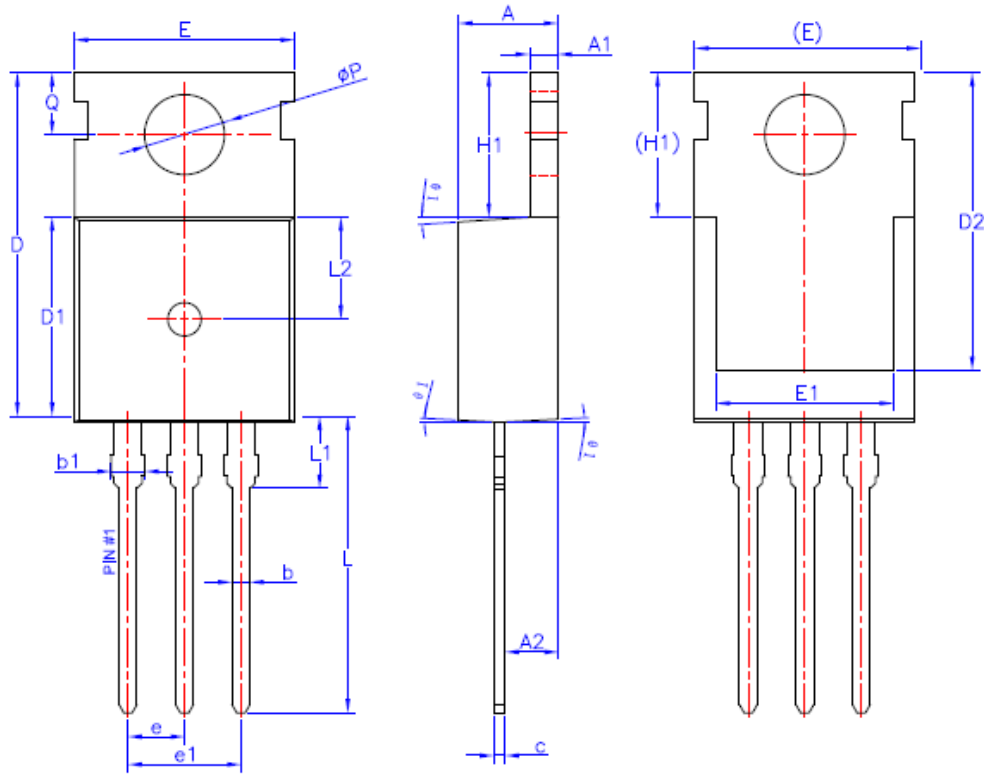

SYMBOL	MIN	NOM	MAX
A	4.40	4.50	4.60
A1	1.27	1.30	1.33
A2	2.30	2.40	2.50
b	0.70	—	0.90
b1	1.27	—	1.40
c	0.45	0.50	0.60
D	15.30	15.70	16.10
D1	9.10	9.20	9.30
D2	13.10	—	13.70
E	9.70	9.90	10.20
E1	7.80	8.00	8.20
e	2.54BSC		
e1	5.08BSC		
H1	6.30	6.50	6.70
L	12.78	13.08	13.38
L1	—	—	3.50
L2	4.60REF		
φP	3.55	3.60	3.65
Q	2.73	—	2.87
#1	1°	3°	5°



# SPN60T15

## N-Channel Enhancement Mode MOSFET

### TO-220F-3L PACKAGE OUTLINE

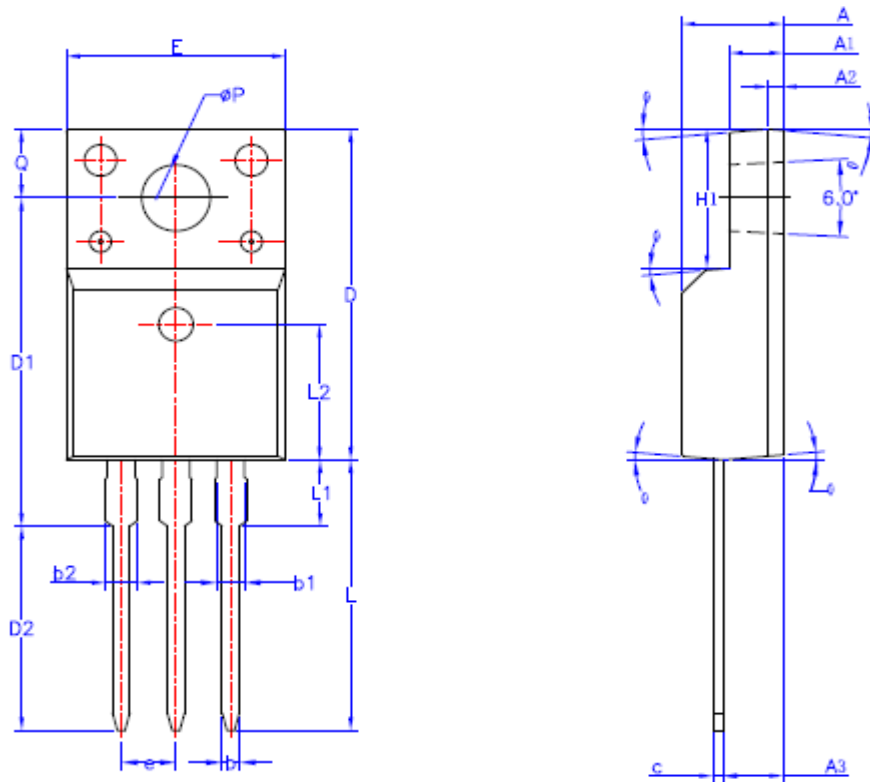

SYMBOL	MIN	NOM	MAX
A	4.50	4.70	4.83
A1	2.34	2.54	2.74
A2	0.70 REF		
A3	2.56	2.76	2.93
b	0.70	—	0.90
b1	1.18	—	1.38
b2	—	—	1.47
c	0.45	0.50	0.60
D	15.67	15.87	16.07
D1	15.55	15.75	15.95
D2	9.60	9.80	10.0
E	9.96	10.16	10.36
e	2.54BSC		
H1	6.48	6.68	6.88
L	12.68	12.98	13.28
L1	—	—	3.50
L2	6.50REF		
∅P	3.08	3.18	3.28
Q	3.20	—	3.40
θ 1	1°	3°	5°





# SPN60T15

## N-Channel Enhancement Mode MOSFET

### PPAK5x6-8L PACKAGE OUTLINE

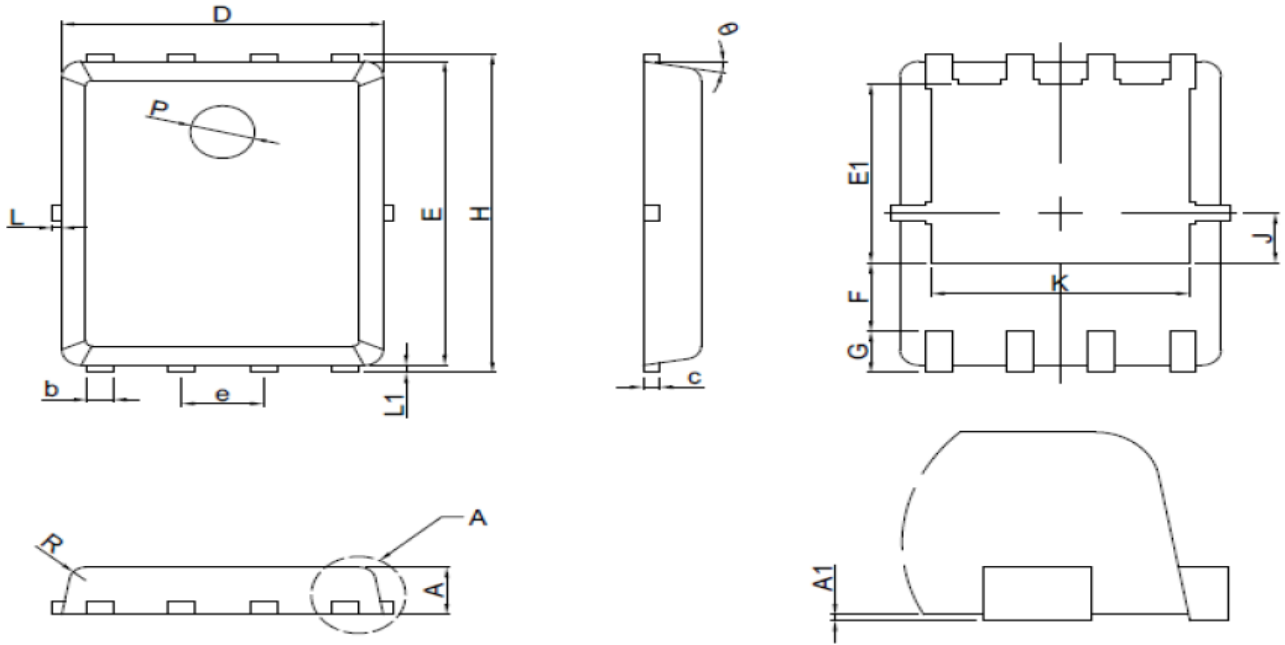

SYMBOL	MILLIMETERS		
	MIN	NOM	MAX
A	0.8	0.95	1.1
A1	0.00	0.03	0.05
b	0.33	0.41	0.51
c	0.254 REF		
D	4.80	4.95	5.10
F	1.40 REF		
E	5.70	5.80	5.90
e	1.27 BSC		
H	5.90	6.05	6.20
L1	0.06	0.13	0.20
G	0.60 REF		
J	0.95 BSC		
K	4.00 REF		
L	---	----	0.20
P	1.00 REF		
E1	3.40REF		
E2	0.95 REF		
$\theta$	6°	10°	14°
R	0.25REF		



# SPN60T15

## N-Channel Enhancement Mode MOSFET

---

Information provided is alleged to be exact and consistent. SYNC Power Corporation presumes no responsibility for the penalties of use of such information or for any violation of patents or other rights of third parties which may result from its use. No license is granted by allegation or otherwise under any patent or patent rights of SYNC Power Corporation. Conditions mentioned in this publication are subject to change without notice. This publication surpasses and replaces all information previously supplied. SYNC Power Corporation products are not authorized for use as critical components in life support devices or systems without express written approval of SYNC Power Corporation.

© The SYNC Power logo is a registered trademark of SYNC Power Corporation

© 2017 SYNC Power Corporation – Printed in Taiwan – All Rights Reserved

SYNC Power Corporation

7F-2, No.3-1, Park Street

NanKang District (NKSP), Taipei, Taiwan 115

Phone: 886-2-2655-8178

Fax: 886-2-2655-8468

© <http://www.syncpower.com>