

58V Asynchronous Buck Converter

❖ GENERAL DESCRIPTION

The MA5802 is a monolithic asynchronous buck regulator. The device integrates 110mΩ MOSFET, and provides 2A of continuous load current over a wide input voltage of 10V to 58V. Current mode control provides fast transient response and cycle-bicycle current limit.

The internal soft-start function prevents inrush current at turn-on, This device, available in an SOP8L-EP(Exposed pad) package, provides a very compact solution with minimal external components.

❖ FEATURES

- Wide 10V to 58V Operating Input Range
- Integrated 110mΩ P-channel MOSFET Switches
- Output Adjustable :VFB(1.00V±2%)
- Up to 93% Efficiency
- Internal Soft-Start
- Fixed 240KHz Frequency
- Cycle-by-Cycle Over Current Protection
- Input Under/Over Voltage Lockout

❖ APPLICATION CIRCUIT

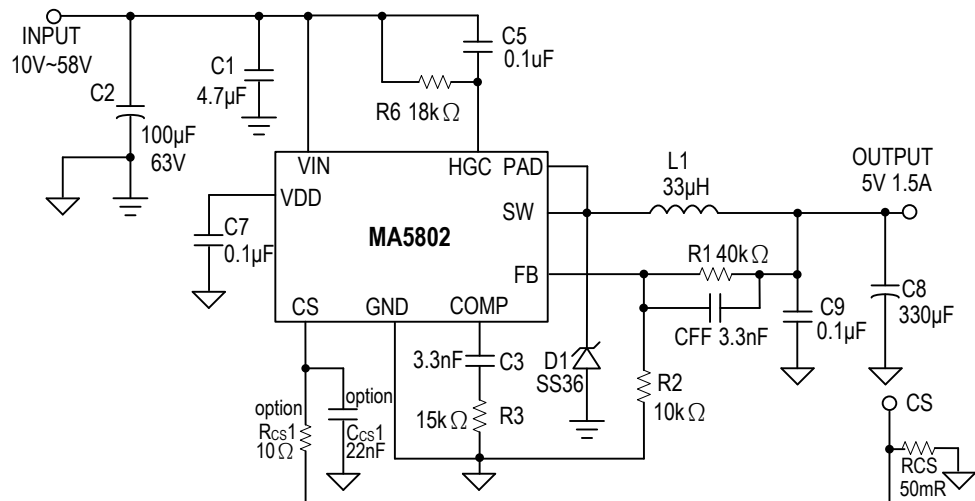

$$V_{OUT} = V_{FB} \times (1 + R1/R2), \quad V_{FB} = 1.0V, \quad R2 \text{ suggest } 1K \sim 20K\Omega.$$

$$I_{CS} = V_{CS} / R_{CS} = 0.1V / 50m\Omega = 2.0A$$

❖ PIN ASSIGNMENT

The package of MA5802 is SOP8L-EP(Exposed pad); the pin assignment is given by:

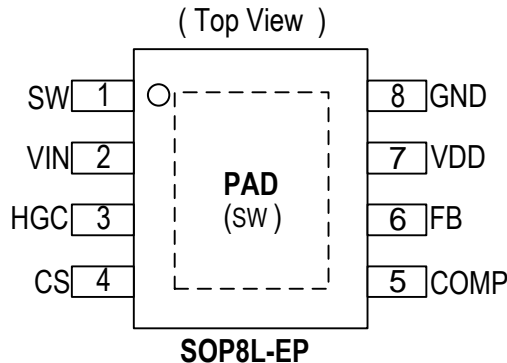

Name	Description
SW	Power Switching Output. SW is the switching node that supplies power to the output. Connect the output LC filter from SW to the output load.
VIN	Power Input. Bypass VIN to Ground with a suitably high capacitance E-CAP to eliminate noise, and bypass IC PIN2-VIN to pin8-GND with a 4.7uf ceramic MLCC (e.g. X5R.)
HGC	Supply high-side gate driver. Decouple this pin to VIN pin with 0.1uf ceramic CAP (e.g. X5R) and 18kΩ resistor.
CS	The Current Sense pin.
COMP	Compensation Node. COMP is used to compensate the regulation control loop. Connect a series RC network from COMP to GND to compensate the regulation control loop.
FB	Feedback Input. FB senses the output voltage to regulate that voltage. Drive FB with a resistive voltage divider from the output voltage.
VDD	Internal regulator pin
GND	Ground.
PAD	SW (Connect to SW).

❖ ORDER/MARKING INFORMATION

Order Information	Top Marking
<p>MA5802XXX → Packing Blank: Tube A : Taping</p> <p>Package Type ES: SOP8L-EP</p>	<p>MA5802 → Part number XXXXX → ID code:internal → WW:01~52 → Year:18=2018</p>

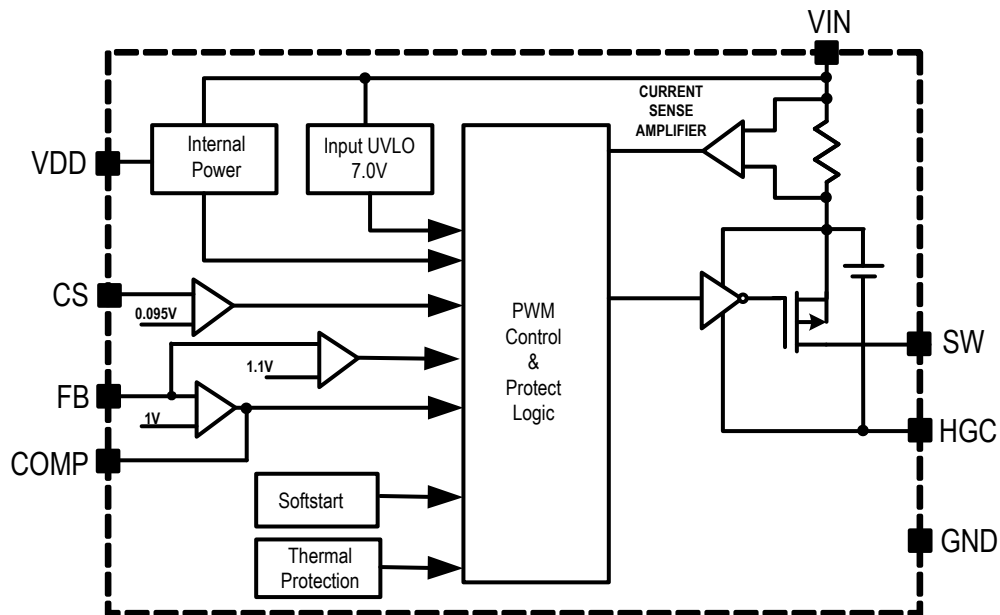
❖ ABSOLUTE MAXIMUM RATINGS (at $T_A=25^{\circ}\text{C}$)

Characteristics	Symbol	Rating	Unit
Supply Voltage	V_{IN}	-0.3 to +63	V
Switch Node Voltage	V_{SW}	-0.3 to $V_{IN} + 0.3$	V
HGC Node Voltage	V_{HGC}	-0.3 to $V_{IN} + 0.3$	V
All Other Pins		-0.3 to +6	V
Lead Temperature		260	$^{\circ}\text{C}$
Storage Temperature		-65 to +150	$^{\circ}\text{C}$
Junction Temperature	T_J	150	$^{\circ}\text{C}$
Input Voltage	V_{IN}	10 to 58	V
Ambient Operating Temperature		-40 to +85	$^{\circ}\text{C}$
Thermal Resistance from Junction to case	θ_{JC}	15	$^{\circ}\text{C}/\text{W}$
Thermal Resistance from Junction to ambient	θ_{JA}	40	$^{\circ}\text{C}/\text{W}$

Note: θ_{JA} is measured with the PCB copper area of approximately 1 in²(Multi-layer). That need connect to exposed pad.

❖ ELECTRICAL CHARACTERISTICS

 ($V_{IN} = 24V$, $T_A = +25^{\circ}C$, unless otherwise noted.)

Characteristics	Symbol	Conditions	Min	Typ	Max	Units
Quiescent Current	I_{CCQ}	$V_{EN} = 5.0V$; $V_{FB} = 1.1V$	-	4	7	mA
Feedback Voltage	V_{FB}		0.98	1.00	1.02	V
Feedback Overvoltage Threshold	$OVP_{(FB)}$		-	1.1X	-	V_{FB}
High-Side Switch On Resistance (Note)	$R_{DS(ON)1}$		-	110	-	m Ω
High-Side Switch Leakage Current		$V_{EN} = 0V$, $V_{SW} = 0V$	-	-	10	μA
HGC voltage(Note)	V_{HGC}		-	5	-	V
Current Limit(Note)	I_{CL}		2.9	3.5	-	A
Oscillation Frequency	F_{OSC1}		-	240	-	KHz
Short Circuit Oscillation Frequency	F_{OSC2}	$V_{FB} = 0V$	-	80	-	KHz
Maximum Duty Cycle	D_{MAX}		-	100	-	%
Minimum On Time (Note)	$T_{ON(min)}$		-	220	-	ns
Current Sense Voltage	V_{CS}		90	100	110	mV
Input Under Voltage Lockout Threshold	UVLO	V_{IN} Rising	8.0	9.0	9.7	V
Input Under Voltage Lockout Threshold Hysteresis	UVLO-Hys		-	1.5	-	V
Input Over Voltage Lockout Threshold	OVLO	V_{IN} Rising	-	61	-	V
Input Over Voltage Lockout Threshold Hysteresis	OVLO-Hys		-	4	-	V
Soft-Start Period(Note)			-	2	-	ms
Thermal Shutdown(Note)	T_{SD}		-	155	-	$^{\circ}C$
Thermal Shutdown Hysteresis	T_{SH}		-	35	-	$^{\circ}C$

Note: Guaranteed by design.

❖ FUNCTION DESCRIPTIONS

The MA5802 is an asynchronous rectified, current-mode, step-down regulator. It regulates input voltages from 10V to 58V down to an output voltage as low as VFB, and supplies up to 2A of load current.

The MA5802 uses current-mode control to regulate the output voltage. The output voltage is measured at FB through a resistive voltage divider and amplified through the internal Transconductance error amplifier. The voltage at the COMP pin is compared to the switch current measured internally to control the output voltage.

The converter uses internal P-Channel MOSFET switches to step-down the input voltage to the regulated output voltage. Since the high side MOSFET requires a gate voltage low than the input voltage, a clamping capacitor connected between HGC and VIN is needed to drive the high side gate.

When the MA5802 FB pin exceeds 10% of the nominal regulation voltage of VFB, the over voltage comparator is tripped and the COMP pin is discharged to GND, forcing the high-side switch off.

❖ APPLICATION INFORMATION

Setting the Output Voltage

The output voltage is set using a resistive voltage divider from the output voltage to FB pin. The voltage divider divides the output voltage down to the feedback voltage by the ratio.

Thus the output voltage is:

$$V_{OUT} = V_{FB} \times \left(1 + \frac{R1}{R2} \right)$$

For example, VFB = 1.00V for a 5.0V output voltage, R2 is 10kΩ, and R1 is 40kΩ.

Inductor Selection

The inductor is required to supply constant current to the output load while being driven by the switched input voltage. A larger value inductor will result in less ripple current that will result in lower output ripple voltage. However, the larger value inductor will have a larger physical size, higher series resistance, and/or lower saturation current. A good rule for determining the inductance to use is to allow the peak-to-peak ripple current in the inductor to be approximately 30% of the maximum switch current limit.

VOUT	<8V	<15V
Inductor	33uH	47uH

The choice of which style inductor to use mainly depends on the price vs. size requirements and any EMI requirements.

Output Short-Circuit protection

The MA5802 provides output short-circuit protection retry function. When VOUT is short ($V_{FB} < 0.4V$), the auto restart function can be started that restart the regulator cycle by cycle. (Retry time 2mS , Shutdown regulator time 2S) .

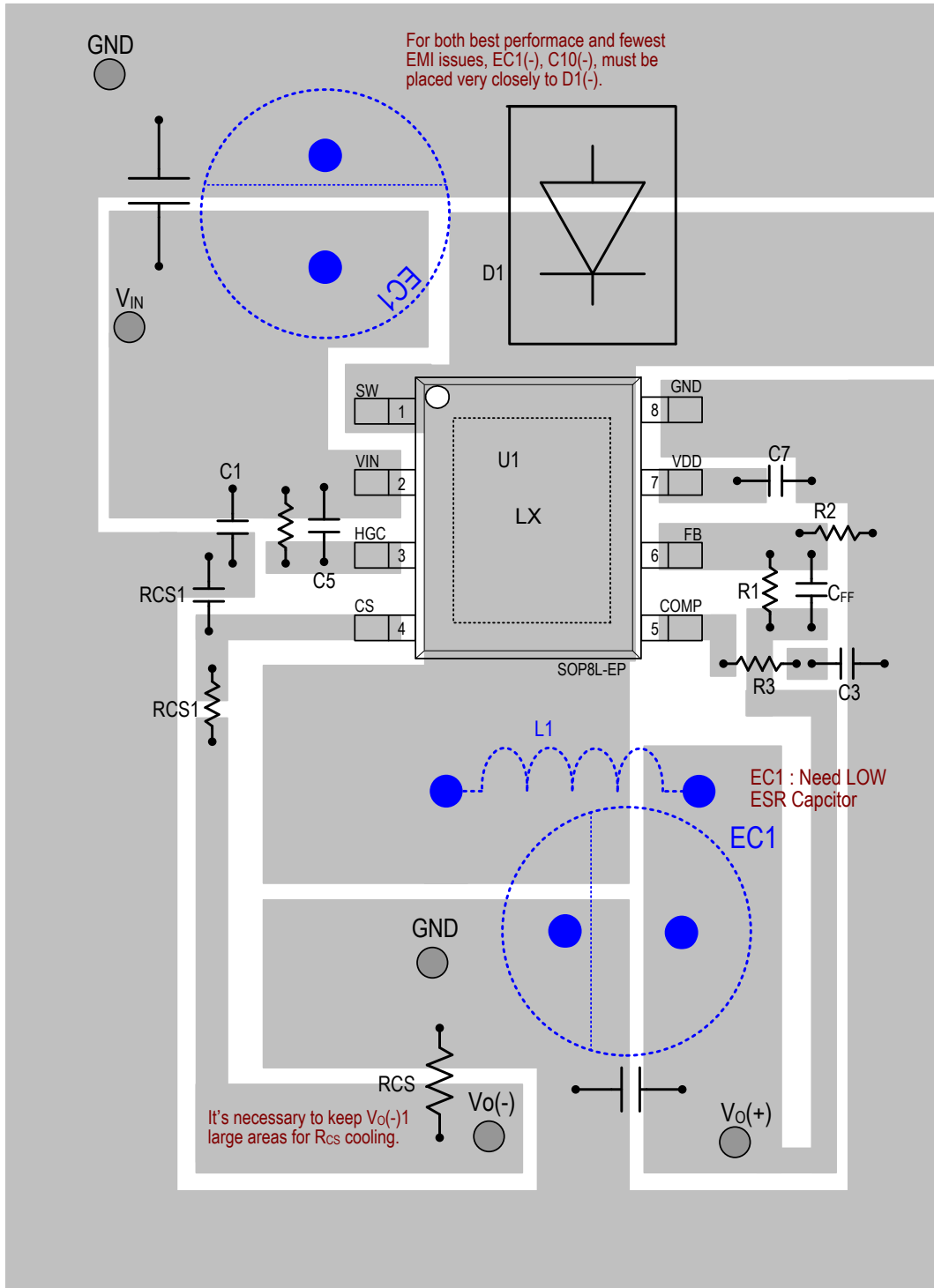
PCB Layout Guideline

PCB Layout Recommendation

When laying-out the PCB, the following rules should be used to ensure proper operation of the MA5802. Check the following in your PCB layout:

1. The power traces (VIN, GND, VO(+), SW) should be kept short, direct and wide.
2. The area of D1(-) cooling PAD should be given 1cm² per layer at least, and 1.5cm² per layer for D1 if output 2A.
3. Keep SW away from all sensitive traces, like VOUT, FB, COMP and CS node.
4. The EC1(-) must be placed very closely to D1(-) GND.

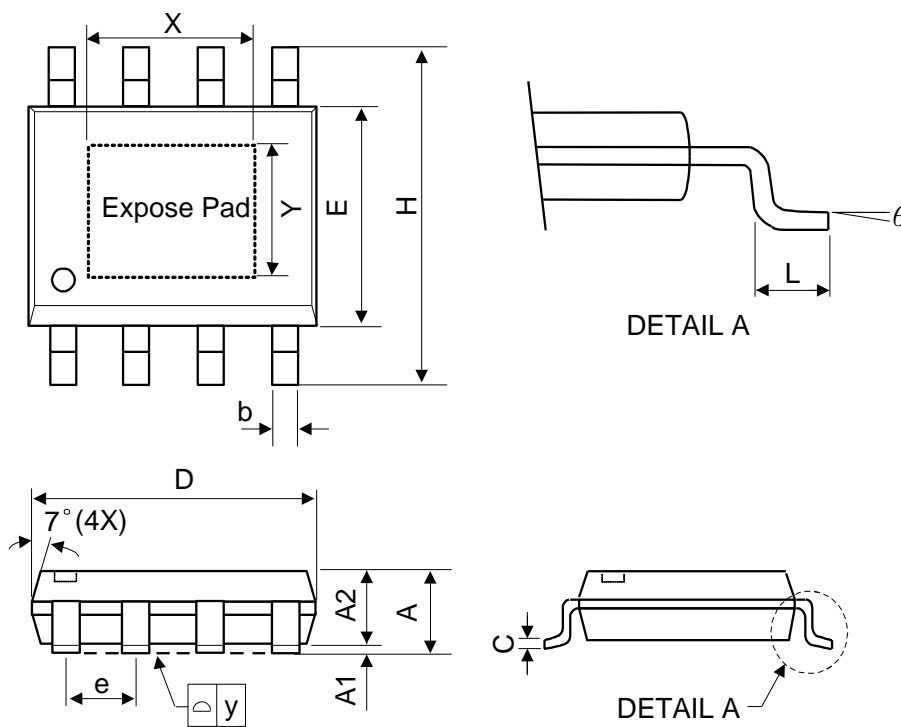
❖ PACKAGE OUTLINES

Symbol	Dimensions in Millimeters			Dimensions in Inches		
	Min.	Nom.	Max.	Min.	Nom.	Max.
A	-	-	1.75	-	-	0.069
A1	0	-	0.15	0	-	0.06
A2	1.25	-	-	0.049	-	-
C	0.1	0.2	0.25	0.0075	0.008	0.01
D	4.7	4.9	5.1	0.185	0.193	0.2
E	3.7	3.9	4.1	0.146	0.154	0.161
H	5.8	6	6.2	0.228	0.236	0.244
L	0.4	-	1.27	0.015	-	0.05
b	0.31	0.41	0.51	0.012	0.016	0.02
e	1.27 BSC			0.050 BSC		
y	-	-	0.1	-	-	0.004
X	-	2.34	3.33	-	0.092	0.131
Y	-	2.34	2.54	-	0.092	0.10
θ	0°	-	8°	0°	-	8°

Mold flash shall not exceed 0.25mm per side

JEDEC outline: MS-012 BA