

## Features

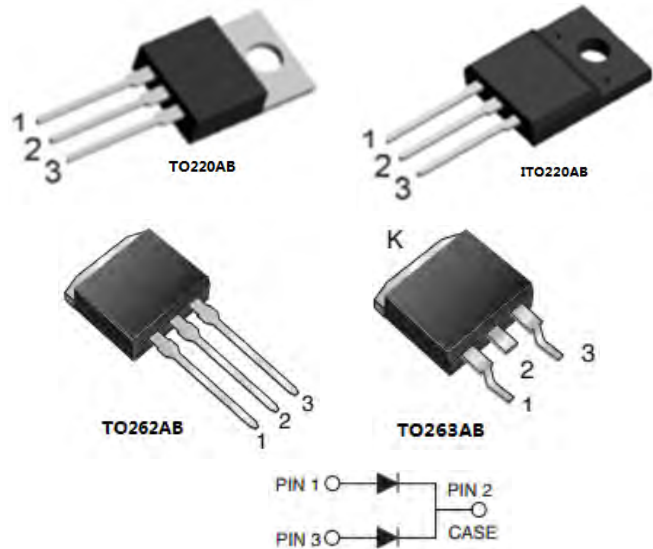
- Ultra Low Forward Voltage Drop
- Excellent High Temperature Stability
- Patented Super Barrier Rectifier Technology
- Soft, Fast Switching Capability

## Mechanical Data

- Case: TO-220AB, ITO-220AB, TO-262AB, TO-263AB
- Case Material: Molded Plastic, UL Flammability Classification Rating 94V-0
- Terminals: Matte Tin Finish annealed over Copper leadframe. Solderable per MIL-STD-202, Method 208

## Ordering Information

Part No.	Package	Packing
SBT30L100CT	TO-220AB	50pcs / Tube
SBT30L100FCT	ITO-220AB	50pcs / Tube
SBT30L100CK	TO-262AB	50pcs / Tube
SBT30L100CG	TO-263AB	50pcs / Tube
SBT30L100CG	TO-263AB	800pcs / Reel



## MAXIMUM RATINGS( $T_A=25^{\circ}\text{C}$ unless otherwise noted)

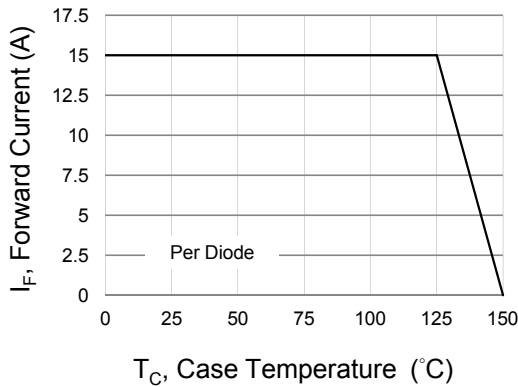
PARAMETER	SYMBOL	VALUE	UNIT
Maximum repetitive peak reverse voltage	$V_{RRM}$	100	V
Maximum rms voltage	$V_{RMS}$	70	V
Maximum average forward rectified current	$I_{F(AV)}$	30 15	A
Peak forward surge current 8.3ms single half sine-wave superimposed on rated load	$I_{FSM}$	250	A
Typical thermal resistance per diode	$R_{\theta JC}$	2	$^{\circ}\text{C/W}$
Operating junction temperature range	$T_J$	-55 to + 150	$^{\circ}\text{C}$
Storage temperature range	$T_{STG}$	-55 to + 150	$^{\circ}\text{C}$

Note : 1. Mounted on infinite heatsink.

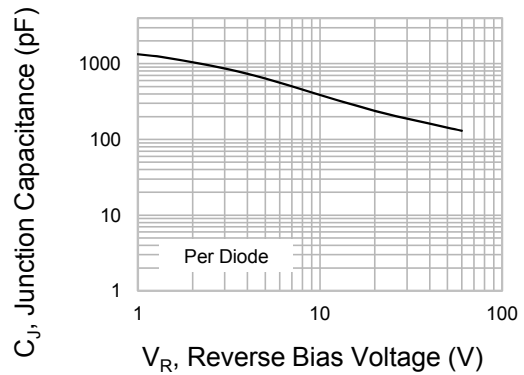
**ELECTRICAL CHARACTERISTICS**( $T_A=25^{\circ}\text{C}$  unless otherwise noted)

PARAMETER	SYMBOL	TEST CONDITIONS	MIN.	TYP.	MAX.	UNIT	
Breakdown voltage per diode	$V_{BR}$	$I_R=0.5\text{mA}$	100	-	-	V	
Instantaneous forward voltage per diode	$V_F$	$I_F=3\text{A}$	-	0.45	-	V	
		$I_F=5\text{A}$	-	0.47	-		
		$I_F=15\text{A}$	-	0.65	0.70		
				$T_J=25^{\circ}\text{C}$			
Instantaneous forward voltage per diode	$V_F$	$I_F=3\text{A}$	-	0.34	-	V	
		$I_F=5\text{A}$	-	0.44	-		
				$T_J=125^{\circ}\text{C}$			
				$T_J=125^{\circ}\text{C}$			
Reverse current per diode	$I_R$	$V_R=70\text{V}$	-	5	-	$\mu\text{A}$	
		$V_R=100\text{V}$	-	-	100	$\mu\text{A}$	
			-	8.5	-	mA	

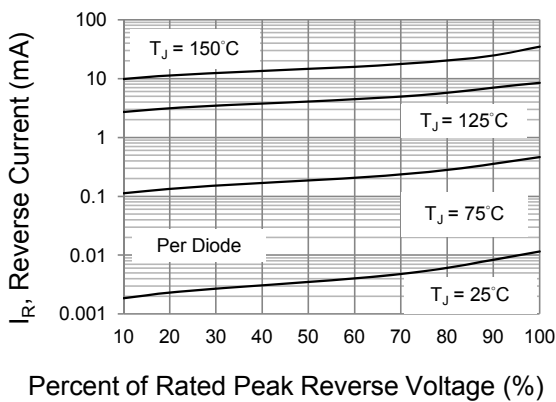
**RATING AND CHARACTERISTIC CURVES**



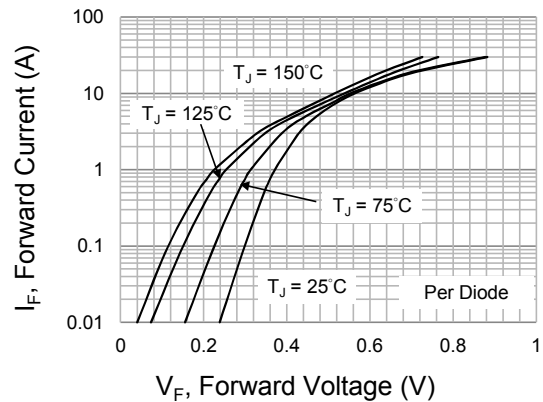
**Fig.1 Forward Current Derating Curve**



**Fig.2 Typical Junction Capacitance**

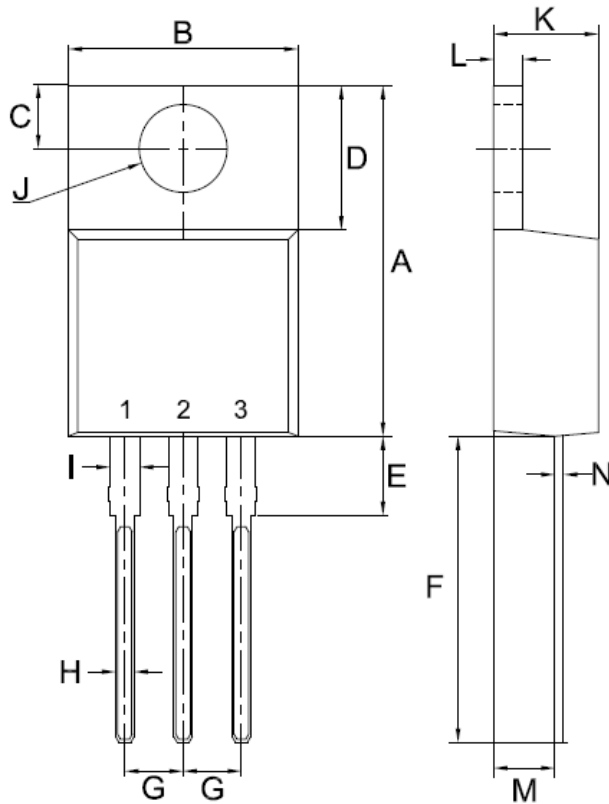


**Fig.3 Typical Reverse Characteristics**

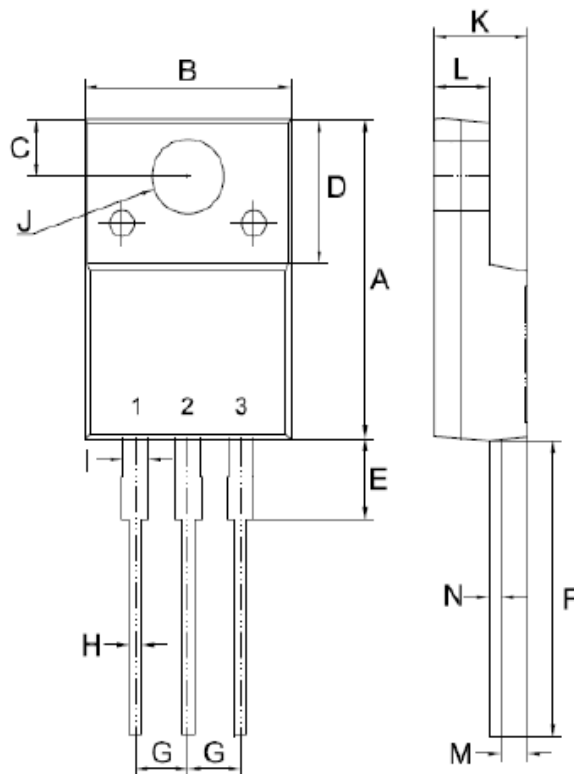


**Fig.4 Typical Forward Characteristics**

**Package Outline Dimensions**

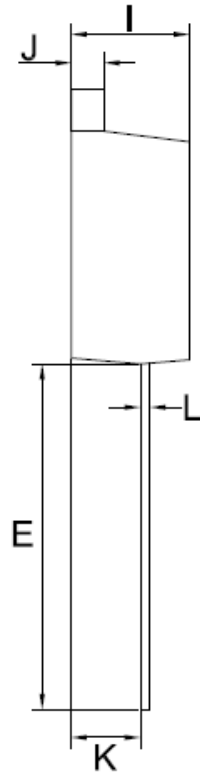
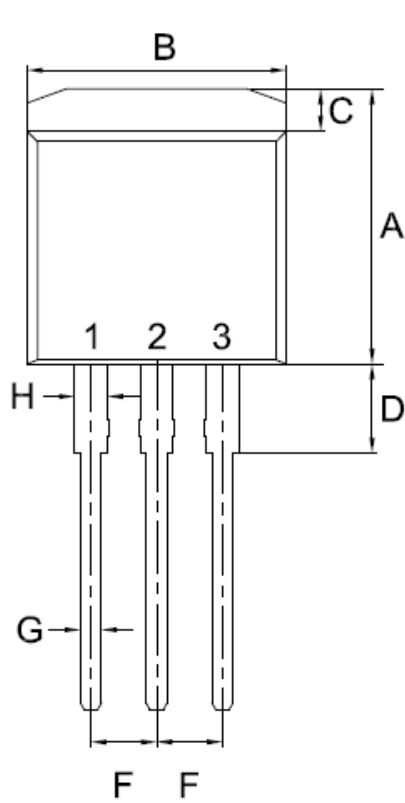


TO-220AB		
Unit:mm		
DIM	MIN	MAX
A	14.80	15.80
B	9.57	10.57
C	2.54	2.94
D	5.80	6.80
E	2.95	3.95
F	12.70	13.40
G	2.34	2.74
H	0.51	1.11
I	0.97	1.57
J	3.54 $\phi$	4.14 $\phi$
K	4.27	4.87
L	1.07	1.47
M	2.03	2.92
N	0.30	0.64

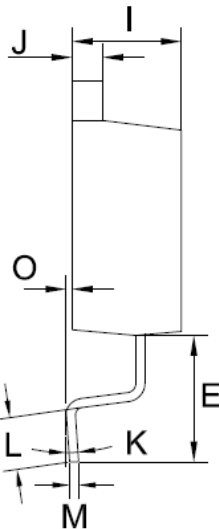
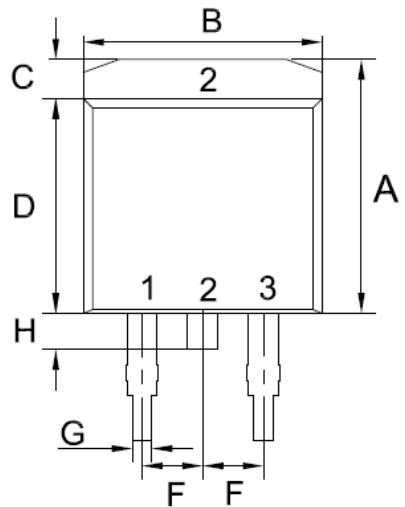


ITO-220AB		
Unit:mm		
DIM	MIN	MAX
A	14.50	15.50
B	9.50	10.50
C	2.50	2.90
D	6.30	7.30
E	3.30	4.30
F	13.00	14.00
G	2.35	2.75
H	0.30	0.90
I	0.90	1.50
J	3.20	3.80
K	4.24	4.84
L	2.52	2.92
M	1.09	1.49
N	0.47	0.64

**Package Outline Dimensions**



TO-262 (I <sup>2</sup> PAK)		
Unit:mm		
DIM	MIN	MAX
A	10.14	11.14
B	9.57	10.57
C	1.44	1.84
D	2.95	3.95
E	12.70	13.40
F	2.34	2.74
G	0.51	1.11
H	0.97	1.57
I	4.27	4.87
J	1.07	1.47
K	2.03	2.92
L	0.30	0.46



TO-263 (D <sup>2</sup> PAK)		
Unit:mm		
DIM	MIN	MAX
A	10.44	10.84
B	9.81	10.21
C	1.44	1.84
D	8.80	9.20
E	4.46	4.66
F	2.44	2.64
G	0.61	1.01
H	0.70	1.30
I	4.27	4.87
J	1.07	1.47
K	0°	8°
L	2.10	2.50
M	0.30	0.46
O	0	0.25