



SP2260

60V Buck LED Driver

DESCRIPTION

SP2260 is the monolithic IC designed for a step-down LED driver capable of driving 1.5A/3A load without an additional transistor. The input voltage range is up to 60V. Its feedback voltage, VFB, is 200mV. The SP2260 operates at a switching frequency of 52kHz. The external shutdown function is controlled by a logic level on the EN pin and then the circuit comes into the standby mode with $I_{STBY} \sim 50\mu A$ (typ.). As the voltage on the EN pin is increased from 0.07V to 0.67V, the voltage on the FB pin falls from 200mV to 0. The self-protection features include a cycle-by-cycle current limit and a thermal protection. SP2260 is available in standard TO-263 and SOP-8 with power pad. package.

APPLICATIONS

- DC/DC LED driver applications
- Backlighting for flat panel displays
- General purpose constant current source
- Automotive
- Chargers

FEATURES

- VIN Max = 60V
- VFB = 200mV
- Frequency 52kHz
- ILED Max 1.5A with PSOP-8L
- ILED Max 3.0A with TO-263-5L
- On/Off control input may be used for the EN pin
- Thermal protection
- Cycle-by-cycle current limit

PIN CONFIGURATION

PSOP-8L

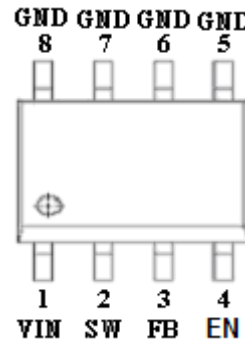

TO-263-5L

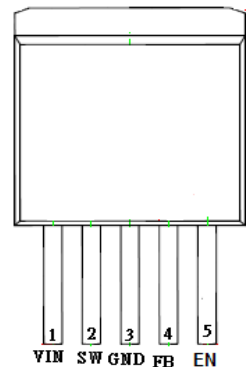

PART MARKING

PSOP-8L



A : Lot Code
B : Date Code

TO-263-5L

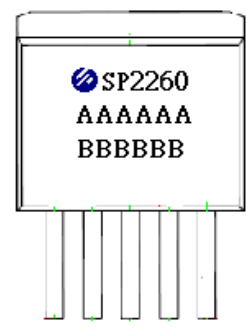

A : Lot Code
B : Date Code



SP2260

60V Buck LED Driver

TYPICAL APPLICATION CIRCUIT

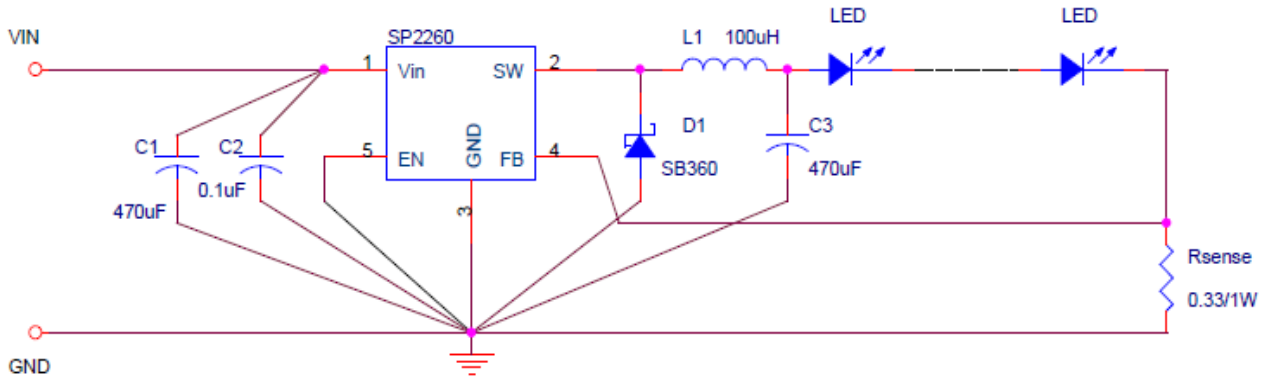

PIN DESCRIPTION

Pin (PSOP-8L)	Pin (TO263-5)	Symbol	Description
1	1	V _{IN}	Supply Voltage Input
2	2	SW	Switch
3	4	FB	Feedback
4	5	EN	Enable control, Active low
5~8	3	GND	Ground

ORDERING INFORMATION

Part Number	Package	Part Marking
SP2260S8RG	PSOP- 8L	SP2260
SP2260T265RG	TO-263-5L	SP2260

- ※ SP2260S8RG : 13" Tape Reel ; Pb – Free
- ※ SP2260S8RGB : 13" Tape Reel ; Pb – Free; Halogen – Free
- ※ SP2260T265RG : 13" Tape Reel ; Pb – Free
- ※ SP2260T265RGB : 13" Tape Reel ; Pb – Free; Halogen – Free

BLOCK DIAGRAM

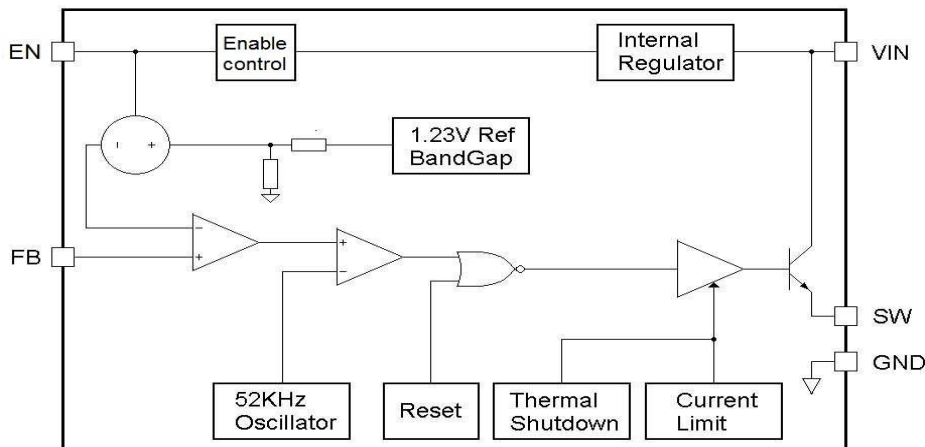



SP2260

60V Buck LED Driver

ABSOLUTE MAXIMUM RATINGS

(T_A=25°C Unless otherwise specified)

Parameter	Symbol	Value	Unit
DC Supply Voltage	V _{IN}	63	V
EN Voltage	EN	-0.3~V _{IN}	V
SW Voltage	SW	-0.8	V
FB Voltage	FB	-0.3~V _{IN}	V
Operating Temperature	T _{OPR}	-40~125	°C
Maximum Junction Temperature	T _{J(Max)}	150	°C
Storage Temperature	T _S	-65~150	°C

The IC has a protection circuit against static electricity. Do not apply high static electricity or high voltage that exceeds the performance of the protection circuit to the IC.

ELECTRICAL CHARACTERISTICS

(T_j=25°C, V_{IN}=12V, I_{LOAD}=350mA Unless otherwise specified)

Symbol	Parameter	Conditions	Min.	Typ.	Max.	Unit
V _{IN}	Operating Voltage		5.5		60	V
V _{FB}	Feedback Voltage	V _{IN} = 12V, I _{LOAD} = 350mA, EN = 0V	190	200	210	mV
		V _{IN} = 5.5V~60V, I _{LOAD} = 350mA, V _{EN} = 0V	180		220	mV
I _{FB}	Feedback Current	V _{FB} = 250mV, EN= 0V	-150	-50	150	nA
F _{OSC}	Oscillator Frequency		47	52	58	KHz
V _{SAT}	Saturation Current	I _{SW} =1.5A PSOP-8L		1.35	1.5	V
		I _{SW} =3.0A TO-263-5L		1.35	1.5	V
D _{MAX}	Max Duty				100	%
I _{LO}	SW Leakage Current	V _{IN} =60V, V _{FB} = 1.5V, V _{SW} = 0V	-0.3	-0.07		mA
CL	Current Limit	PSOP-8L	2.5		4.5	A
		TO-263-5L	4.5		6.5	A
V _{TH}	EN Threshold Voltage		1.0	1.4	2.0	V
I _{IH}	Input Current On/Off	V _{EN} = 2.5V	-1.0	0.01	1.0	uA
I _{IL}	Input Current On/Off	V _{EN} = 0 V	-1.0	-0.3	1.0	uA
I _Q	Quiescent Current	V _{FB} = 1.5V		5.3	10	mA
I _{STBY}	Standby Current	V _{IN} =60V, V _{EN} = 5V		50	200	uA
V _{EN}	Enable Voltage	V _{IN} = 12V, I _{LOAD} = 0	600	670	750	mV



SP2260

60V Buck LED Driver

PERFORMANCE CHARACTERISTICS

(Circuit for typical application circuit)

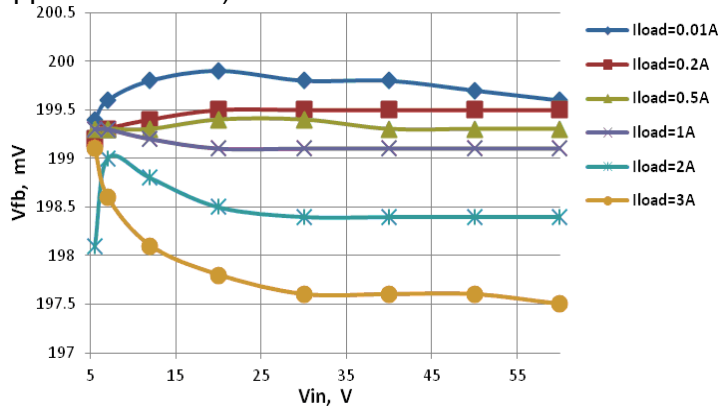

Fig.1 Feedback Voltage

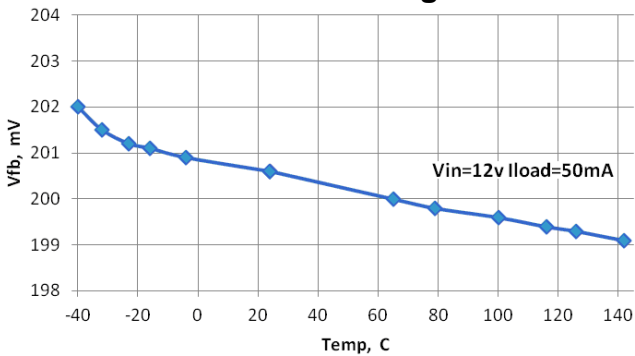

Fig.2 Normalized Feedback Voltage

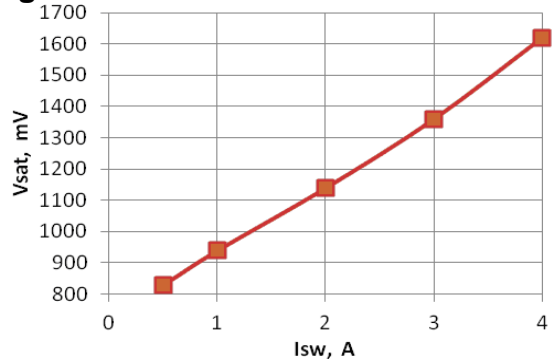

Fig.3 Switch Saturation Voltage

(no any components connected to SW-pin. Vfb=0)

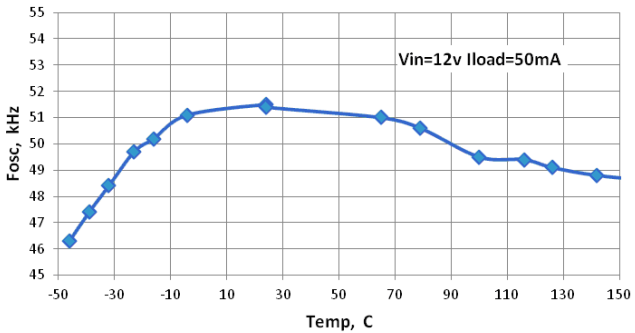

Fig.4 Oscillator Frequency

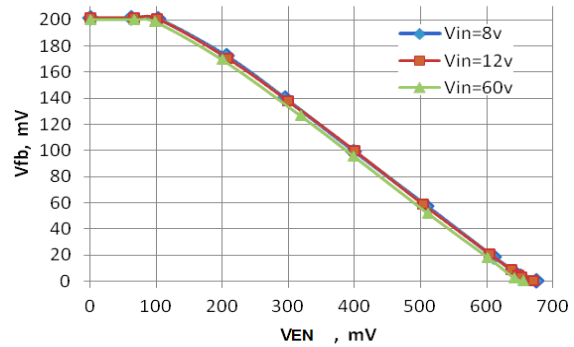

Fig.5 EN vs Vfb Voltage



SP2260

60V Buck LED Driver

PSOP- 8L PACKAGE OUTLINE

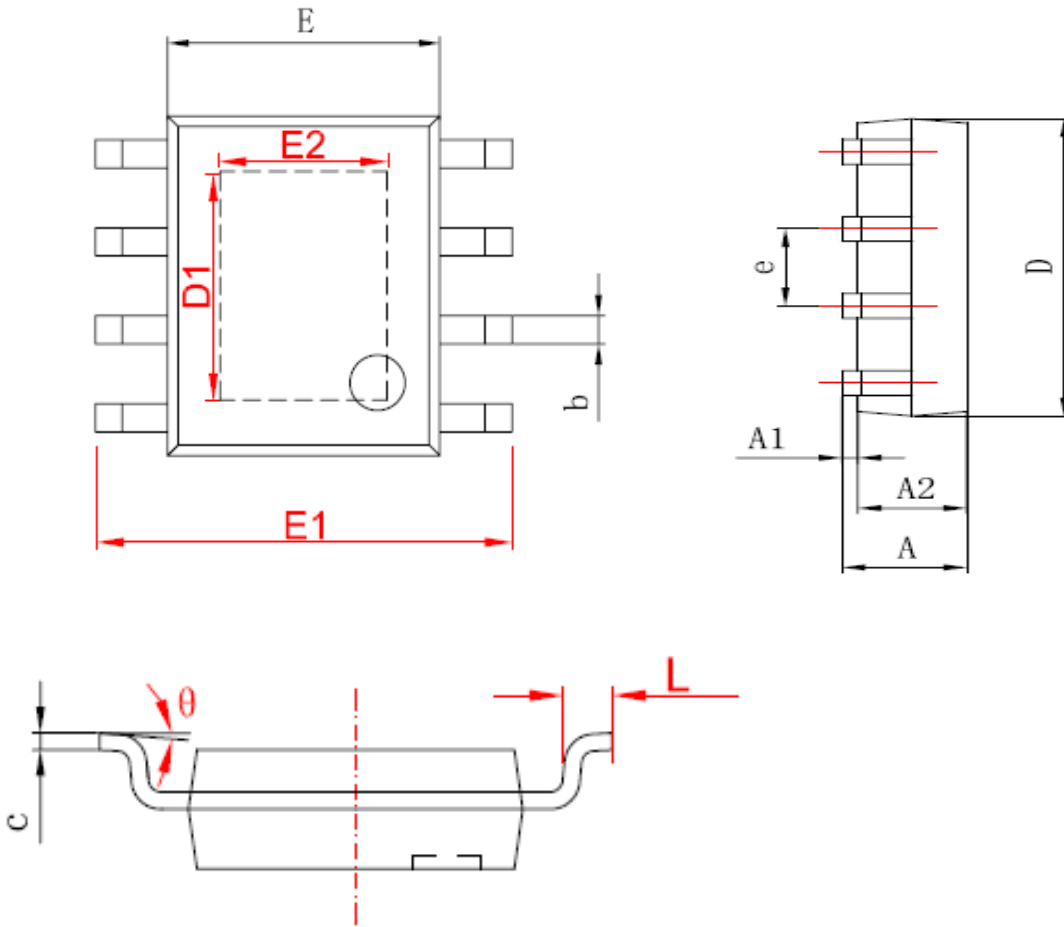

字符	Dimensions In Millimeters		Dimensions In Inches	
	Min	Max	Min	Max
A	1.350	1.750	0.053	0.069
A1	0.050	0.150	0.004	0.010
A2	1.350	1.550	0.053	0.061
b	0.330	0.510	0.013	0.020
c	0.170	0.250	0.006	0.010
D	4.700	5.100	0.185	0.200
D1	3.202	3.402	0.126	0.134
E	3.800	4.000	0.150	0.157
E1	5.800	6.200	0.228	0.244
E2	2.313	2.513	0.091	0.099
e	1.270 (BSC)		0.050 (BSC)	
L	0.400	1.270	0.016	0.050
theta	0°	8°	0°	8°



SP2260

60V Buck LED Driver

TO-263 PACKAGE OUTLINE

TO-263-5L PACKAGE OUTLINE DIMENSIONS

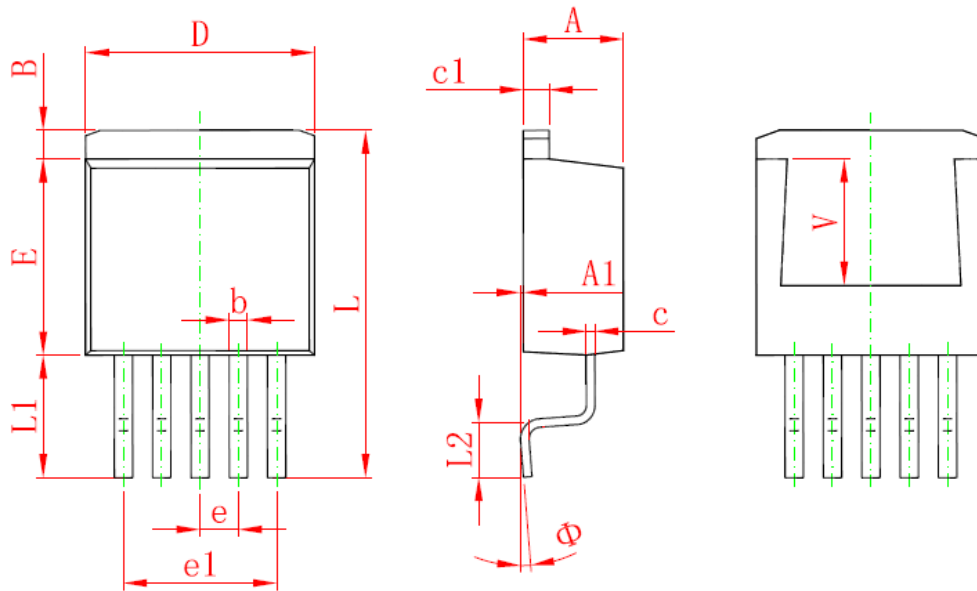

Symbol	Dimensions In Millimeters		Dimensions In Inches	
	Min.	Max.	Min.	Max.
A	4.470	4.670	0.176	0.184
A1	0.000	0.150	0.000	0.006
B	1.560	1.760	0.061	0.069
b	0.710	0.910	0.028	0.036
c	0.310	0.530	0.012	0.021
c1	1.170	1.370	0.046	0.054
D	9.880	10.180	0.389	0.401
E	8.200	8.600	0.323	0.339
e	1.700 TYP.		0.067 TYP.	
e1	6.700	6.900	0.264	0.272
L	15.140	15.540	0.596	0.612
L1	5.080	5.480	0.200	0.216
L2	2.340	2.740	0.092	0.108
Φ	0°	8°	0°	8°
V	5.600 REF.		0.220 REF.	



SP2260

60V Buck LED Driver

Information provided is alleged to be exact and consistent. SYNC Power Corporation presumes no responsibility for the penalties of use of such information or for any violation of patents or other rights of third parties which may result from its use. No license is granted by allegation or otherwise under any patent or patent rights of SYNC Power Corporation. Conditions mentioned in this publication are subject to change without notice. This publication surpasses and replaces all information previously supplied. SYNC Power Corporation products are not authorized for use as critical components in life support devices or systems without express written approval of SYNC Power Corporation.

©The SYNC Power logo is a registered trademark of SYNC Power Corporation

©2018 SYNC Power Corporation – Printed in Taiwan – All Rights Reserved

SYNC Power Corporation

7F-2, No.3-1, Park Street

NanKang District (NKSP), Taipei, Taiwan 115

Phone: 886-2-2655-8178

Fax: 886-2-2655-8468

<http://www.syncpower.com>