



SPE0587

Ultra Low Capacitance 4 -Line ESD Protection Array

DESCRIPTION

The SPE0587 is 4-channel very low capacitance ESD transient voltage suppressor which provides a very high level of protection for sensitive electronic components that may be subjected to electrostatic discharge. It is particularly well-suited to protect systems with high speed communication lines from ESD, EFT, and lightning.

The SPE0587 is consists of eight low capacitance steering diodes and a TVS diode in a MSOP-10L package. Each channel of SPE0587 could safely dissipate ESD strikes of $\pm 15\text{kV}$ air discharge as well as $\pm 8\text{kV}$ contact discharge, meeting the requirement of the IEC 61000-4-2 international standard. Using the MIL-STD-883 (Method 3015) specification for Human Body Model (HBM) ESD, the device provides protection for contact discharges to greater than $\pm 15\text{kV}$.

FEATURES

- ◆ Transient protection for data lines to
 - IEC 61000-4-2 (ESD)
 - $\pm 15\text{kV}$ (air)
 - $\pm 8\text{kV}$ (contact)
 - IEC 61000-4-4 (EFT)
 - 40A (5/50ns)
- ◆ Protects five bidirectional I/O lines
- ◆ Working voltage: 5V
- ◆ Low leakage current
- ◆ Low operating and clamping voltages
- ◆ Low capacitance: 0.35 pF typical

APPLICATIONS

- ◆ Cellular Handsets and Accessories
- ◆ Cordless Phone
- ◆ PDA
- ◆ Notebooks and Handhelds
- ◆ Portable Instrumentation
- ◆ Digital Cameras
- ◆ MP3 Player High Definition Multi-Media Interface Protection
- ◆ USB 2.0 Power and Data Line
- ◆ Monitors and Notebook Computers
- ◆ HDSL, IDSL Secondary IC Side Protection
- ◆ 10/100/1000 Ethernet

PIN CONFIGURATION (MSOP-10L)

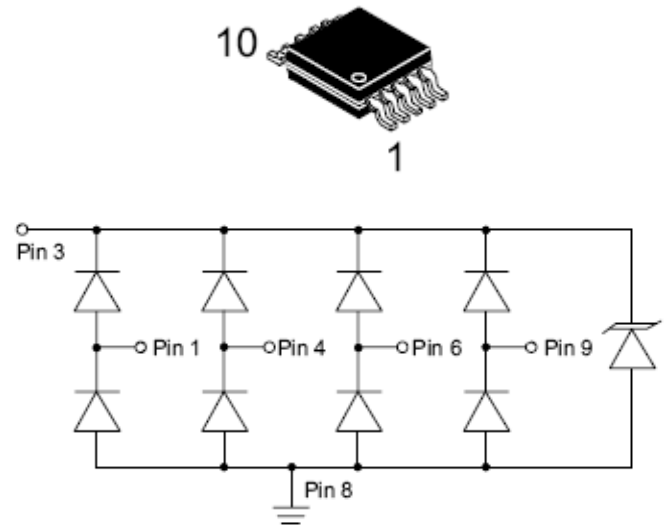

PART MARKING

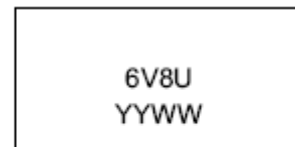

6V8U=Specific Device Code
YYWW=Date Code(y=year,w=week)



SPE0587

Ultra Low Capacitance 4-Line ESD Protection Array

ORDERING INFORMATION

Part Number	Package	Part Marking
SPE0587MS10RGB	MSOP-10L	6V8U YYWW

YYWW =Date Code (YY : 00~99, WW: 01~53)

※ SPE0587MS10RGB : Tape Reel ; Pb – Free ; Halogen – Free

ABSOLUTE MAXIMUM RATINGS

(TA=25°C Unless otherwise noted)

Parameter	Symbol	Typical	Unit
Peak Pulse Power (tp = 8/20 μs)	Ppk	46	W
Maximum Peak Pulse Current (tp = 8/20 μs)	Ipp	4	A
ESD per IEC 61000 – 4 – 2 (Air)	Vpp	±15	KV
ESD per IEC 61000 – 4 – 2 (Contact)	Vpp	±8	KV
Operating Junction Temperature	Tj	-55 ~ 125	°C
Storage Temperature Range	TSTG	-55 ~ 150	°C
Lead Soldering Temperature	TL	260 (10sec)	°C

ELECTRICAL CHARACTERISTICS

(TA=25°C Unless otherwise noted)

Parameter	Symbol	Conditions	Min.	Typ	Max.	Unit
Reverse Stand – Off Voltage	VRWM				5	V
Forward Voltage @ IF	VF	IF = 10mA	0.4	0.8	1.2	V
Reverse Breakdown Voltage	VBR	It = 1mA	6.0	7.0		V
Reverse Leakage Current	IR	VRWM = 5V , T=25°C		0.1	1	μA
Clamping Voltage TLP (I/O to GND) (note1)	Vc	Ipp=8A		13		V
	Vc	IPP=16A		17.5		V
Clamping Voltage	Vc	Ipp = 1A , tp = 8/20 μs			10	V
Junction Capacitance	Cj	VR = 0V, f = 1MHz Any I/O pin to Ground		0.7	1.0	pF
		VR = 0V, f = 1MHz Between I/O pins		0.35		

Notes:

1) TLP parameter: Zo = 50 Ω , tp = 100ns, tr = 10ns, averaging window from 70ns to 90ns.



SPE0587

Ultra Low Capacitance 4-Line ESD Protection Array

TYPICAL CHARACTERISTICS

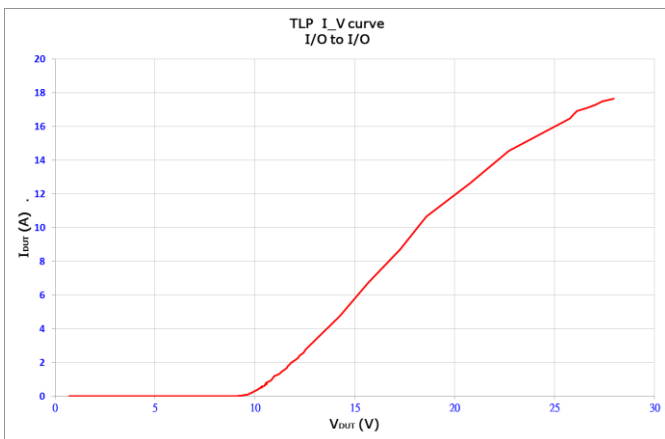
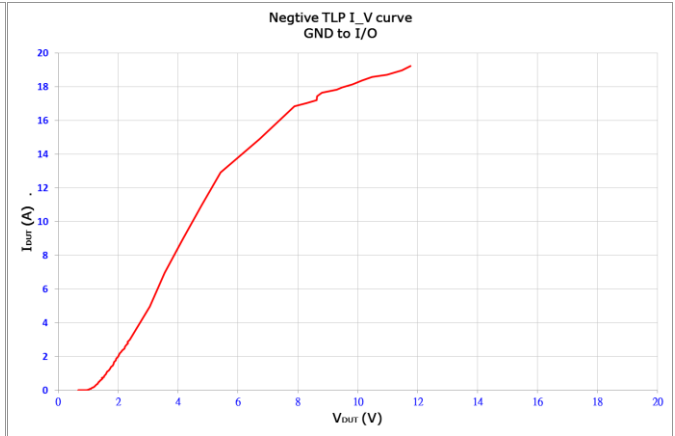
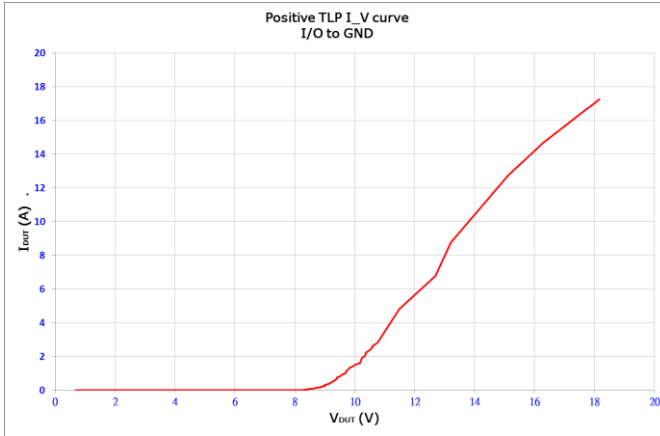



SPE0587

Ultra Low Capacitance 4-Line ESD Protection Array

SCHEMATIC & PIN CONFIGURATION

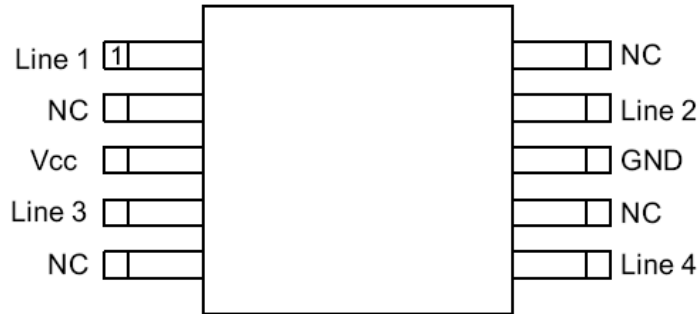

APPLICATION INFORMATION

The HDMI Compliance Test Specification (CTS) requires sink (receiver) ports maintain a differential impedance of 100 Ohms +/- 15%. The measurement is taken using a Time Domain Reflect (TDR) method that utilizes a pulse with a rise time $\leq 200\text{ps}$. ESD protection devices have an inherent junction capacitance. Even a small amount of added capacitance on an HDMI port will cause the impedance of the differential pair to drop. As such, some form of compensation to the layout will be required to bring the differential pairs back within the required 100Ohm +/-15% range. The higher the added capacitance, the more extreme the modifications will need to be. If the added capacitance is too high, compensation may not even be possible. The SPE0587 presents $<1\text{pF}$ capacitance between the pairs while being rated to handle $>8\text{KV}$ ESD contact discharges ($>15\text{KV}$ air discharge) as outlined in IEC 61000-4-2. As such, it is possible to make minor adjustments to the board layout parameters to compensate for the added capacitance of the SPE0587. As figure shows how to implement the SPE0587 in an HDMI application (transmitter and receiver).

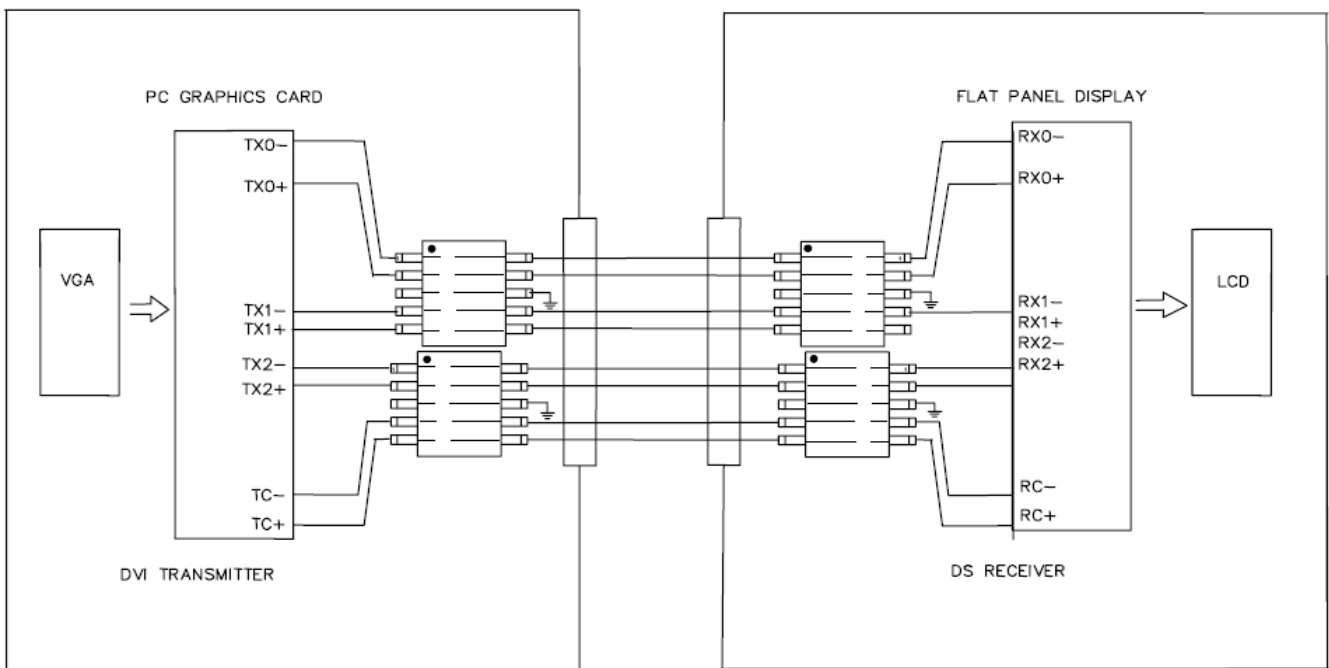

HDMI Schematic



SPE0587

Ultra Low Capacitance 4-Line ESD Protection Array

MSOP-10L PACKAGE OUTLINE

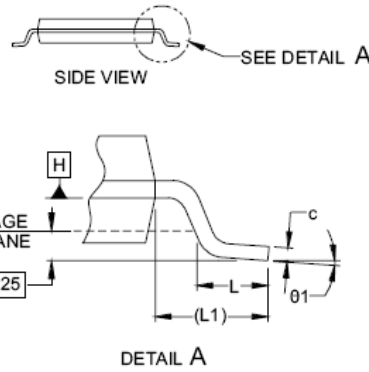
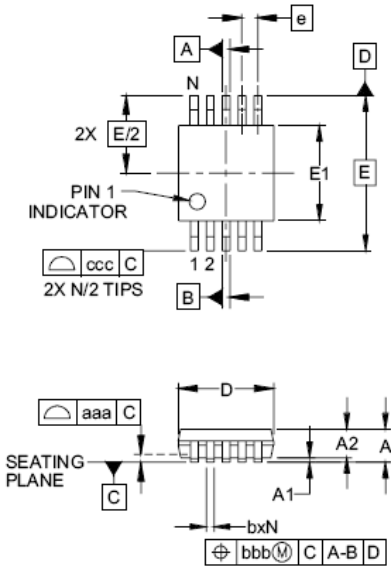

DIM	INCHES			MILLIMETERS		
	MIN	NOM	MAX	MIN	NOM	MAX
A	-	-	.043	-	-	1.10
A1	.000	-	.006	0.00	-	0.15
A2	.030	-	.037	0.75	-	0.95
b	.007	-	.011	0.17	-	0.27
c	.003	-	.009	0.08	-	0.23
D	.114	.118	.122	2.90	3.00	3.10
E1	.114	.118	.122	2.90	3.00	3.10
E	.193 BSC			4.90 BSC		
e	.020 BSC			0.50 BSC		
L	.016	.024	.032	0.40	0.60	0.80
L1	(.037)			(.95)		
N	10			10		
θ_1	0°	-	8°	0°	-	8°
aaa	.004			0.10		
bbb	.003			0.08		
ccc	.010			0.25		

NOTES:

1. CONTROLLING DIMENSIONS ARE IN MILLIMETERS (ANGLES IN DEGREES).
2. DATUMS **-A-** AND **-B-** TO BE DETERMINED AT DATUM PLANE **-H-**
3. DIMENSIONS "E1" AND "D" DO NOT INCLUDE MOLD FLASH, PROTRUSIONS OR GATE BURRS.
4. REFERENCE JEDEC STD MO-187, VARIATION BA.

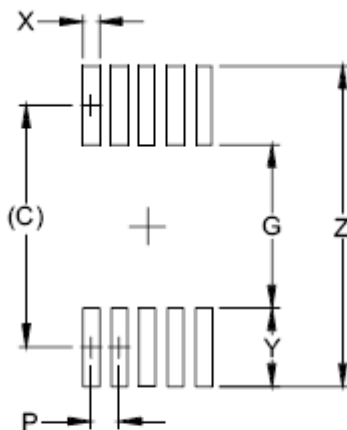

DIMENSIONS		
DIM	INCHES	MILLIMETERS
C	(.161)	(4.10)
G	.098	2.50
P	.020	0.50
X	.011	0.30
Y	.063	1.60
Z	.224	5.70

NOTES:

1. THIS LAND PATTERN IS FOR REFERENCE PURPOSES ONLY. CONSULT YOUR MANUFACTURING GROUP TO ENSURE YOUR COMPANY'S MANUFACTURING GUIDELINES ARE MET.



SPE0587

Ultra Low Capacitance 4 -Line ESD Protection Array

Information provided is alleged to be exact and consistent. SYNC Power Corporation presumes no responsibility for the penalties of use of such information or for any violation of patents or other rights of third parties which may result from its use. No license is granted by allegation or otherwise under any patent or patent rights of SYNC Power Corporation. Conditions mentioned in this publication are subject to change without notice. This publication surpasses and replaces all information previously supplied. SYNC Power Corporation products are not authorized for use as critical components in life support devices or systems without express written approval of SYNC Power Corporation.

© The SYNC Power logo is a registered trademark of SYNC Power Corporation

© 2018 SYNC Power Corporation – Printed in Taiwan – All Rights Reserved

SYNC Power Corporation

7F-2, No.3-1, Park Street

NanKang District (NKSP), Taipei, Taiwan, 115, R.O.C

Phone: 886-2-2655-8178

Fax: 886-2-2655-8468

© <http://www.syncpower.com>