



SPE0588

Ultra Low Capacitance Single-Line ESD Protection Array

DESCRIPTION

The SPE0588 is an ESD transient voltage suppression component which provides a very high level of protection for sensitive electronic components that may be subjected to electrostatic discharge (ESD).

It is particularly well-suited for cellular phones, portable device, digital cameras, power supplies and many other portable applications because of its small package and low weight. The SPE0588 is Uni-directional, Safely dissipate ESD strikes of Level 4, IEC61000-4-2, exceeding the maximum requirement. Using the MILSTD-883 (Method 3015) specification for Human Body Model (HBM) ESD, the device provides protection for contact discharges to greater than +/-10KV.

The SPE0588 is available in a SOD-523 package with peak reverse working voltage of 5 voltages.

APPLICATIONS

- ◆ Cellular Handsets and Accessories
- ◆ Cordless Phone
- ◆ PDA
- ◆ Notebooks and Handhelds
- ◆ Portable Instrumentation
- ◆ Digital Cameras
- ◆ MP3 Player

FEATURES

- ◆ Transient protection for data lines to

IEC 61000-4-2 (ESD)

±15kV (air)

±8kV (contact)

IEC 61000-4-4 (EFT)

40A (5/50ns)

- ◆ Protects single I/O lines
- ◆ Working voltage: 5V
- ◆ Low leakage current
- ◆ Low operating and clamping voltages

PIN CONFIGURATION (SOD-523)

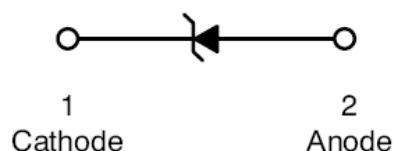
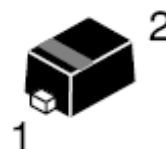

PART MARKING

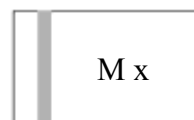

M= Month Code
x=Specific Device Code



SPE0588

Ultra Low Capacitance Single-Line ESD Protection Array

ORDERING INFORMATION

Part Number	Package	Part Marking
SPE0588D52RGB	SOD-523	Mx

M=Month Code (A~Z)

※ SPE0588D52RGB : Tape Reel ; Pb – Free ; Halogen – Free

ABSOLUTE MAXIMUM RATINGS

(TA=25°C Unless otherwise noted)

Parameter	Symbol	Typical	Unit
Peak Pulse Power (tp = 8/20 μs)	Ppk	250	W
Maximum Peak Pulse Current (tp = 8/20 μs)	Ipp	7	A
ESD per IEC 61000 – 4 – 2 (Air)	Vpp	±15	KV
ESD per IEC 61000 – 4 – 2 (Contact)	Vpp	±10	KV
Operating Junction Temperature	Tj	-55 ~ 125	°C
Storage Temperature Range	TSTG	-55 ~ 150	°C
Lead Soldering Temperature	TL	260 (10sec)	°C

ELECTRICAL CHARACTERISTICS

(TA=25°C Unless otherwise noted)

Parameter	Symbol	Conditions	Min.	Typ	Max.	Unit
Reverse Stand – Off Voltage	VRWM				5	V
Reverse Breakdown Voltage	VBR	It = 1mA	6			V
Reverse Leakage Current	IR	VRWM = 5V , T=25°C			1	μA
Clamping Voltage	Vc	Ipp = 1A , tp = 8/20 μs			8	V
Junction Capacitance	Cj	Between I/O Pin and GND VR = 0V , f = 1MHz		0.5	0.9	pF



SPE0588

Ultra Low Capacitance Single-Line ESD Protection Array

TYPICAL CHARACTERISTICS

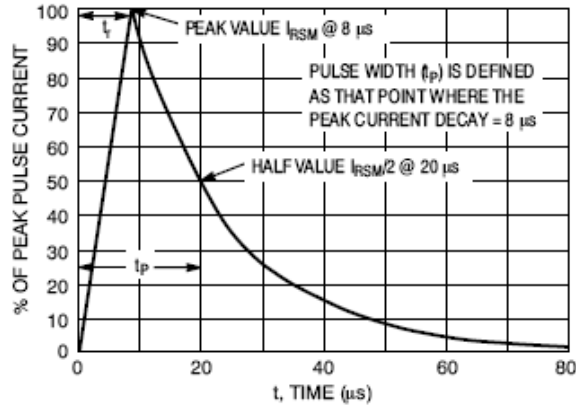

Figure 1. 8 X 20 μ s Pulse Waveform

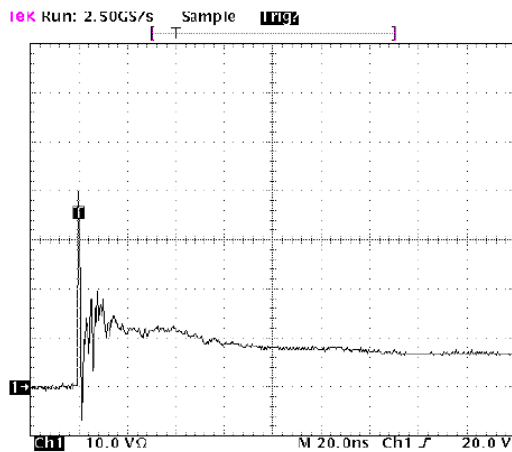

Figure 2. ESD Clamping Voltage Screenshot
Positive 8 kV Contact per IEC61000-4-2

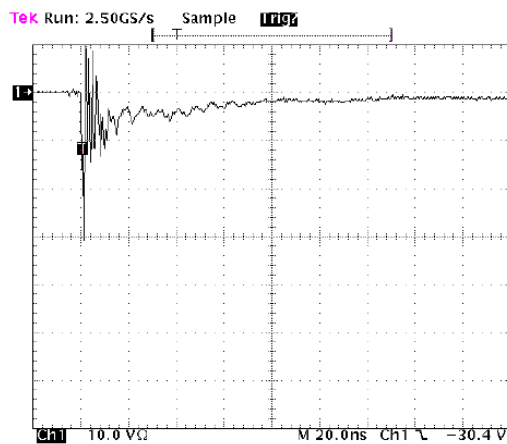

Figure 3. ESD Clamping Voltage Screenshot
Negative 8 kV Contact per IEC61000-4-2



SPE0588

Ultra Low Capacitance Single-Line ESD Protection Array

SOD-523 PACKAGE OUTLINE

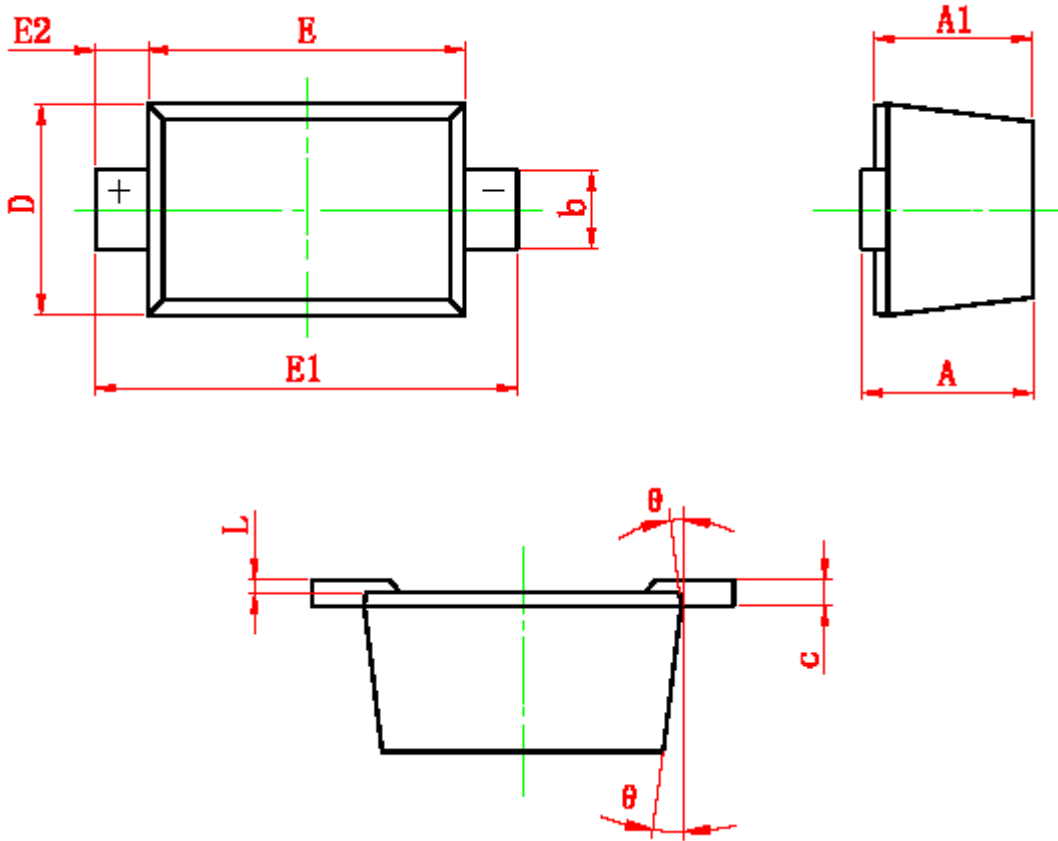

Symbol	Dimensions In Millimeters		Dimensions In Inches	
	Min	Max	Min	Max
A	0.510	0.770	0.020	0.031
A1	0.500	0.700	0.020	0.028
b	0.250	0.350	0.010	0.014
c	0.080	0.150	0.003	0.006
D	0.750	0.850	0.030	0.033
E	1.100	1.300	0.043	0.051
E1	1.500	1.700	0.059	0.067
E2	0.200 REF		0.008 REF	
L	0.010	0.070	0.001	0.003
θ	7° REF		7° REF	



SPE0588

Ultra Low Capacitance Single-Line ESD Protection Array

Information provided is alleged to be exact and consistent. SYNC Power Corporation presumes no responsibility for the penalties of use of such information or for any violation of patents or other rights of third parties which may result from its use. No license is granted by allegation or otherwise under any patent or patent rights of SYNC Power Corporation. Conditions mentioned in this publication are subject to change without notice. This publication surpasses and replaces all information previously supplied. SYNC Power Corporation products are not authorized for use as critical components in life support devices or systems without express written approval of SYNC Power Corporation.

©The SYNC Power logo is a registered trademark of SYNC Power Corporation

©2004 SYNC Power Corporation – Printed in Taiwan – All Rights Reserved

SYNC Power Corporation

7F-2, No.3-1, Park Street

NanKang District (NKSP), Taipei, Taiwan, 115, R.O.C

Phone: 886-2-2655-8178

Fax: 886-2-2655-8468

©<http://www.syncpower.com>