



SPN230T06

N-Channel Enhancement Mode MOSFET

DESCRIPTION

The SPN230T06 is the N-Channel enhancement mode power field effect transistor which is produced using super high cell density DMOS trench technology. This high density process is especially tailored to minimize on-state resistance. These devices are particularly suitable for synchronous rectifier application, Motor control power management and other Power Tool circuits. It has been optimized for low gate charge, low $R_{DS(ON)}$ and fast switching speed.

FEATURES

- ◆ 60V/230A, $R_{DS(ON)}=2.5m\Omega@V_{GS}=10V$
- ◆ High density cell design for extremely low $R_{DS(ON)}$
- ◆ Exceptional on-resistance and maximum DC current capability
- ◆ TO-220-3L and TO-263-2L package design

APPLICATIONS

- AC/DC Synchronous Rectifier
- Load Switch
- UPS
- Power Tool
- Motor Control

PIN CONFIGURATION

TO-220-3L

TO-263-2L

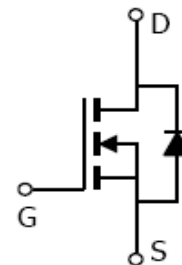
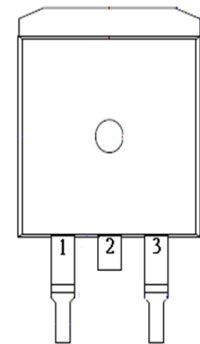
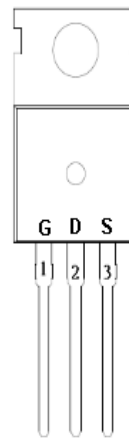

PART MARKING



AAAAA: Wafer lot no
BBBBBB: date code

A : Lot Code
B : Date Code



SPN230T06

N-Channel Enhancement Mode MOSFET

PIN DESCRIPTION

Pin	Symbol	Description
1	G	Gate
2	D	Drain
3	S	Source

ORDERING INFORMATION

Part Number	Package	Part Marking
SPN230T06T220TGB	TO-220-3L	SPN230T06
SPN230T06T262RGB	TO-263-2L	SPN230T06

※ SPN230T06T220TGB : Tube ; Pb – Free ; Halogen - Free

※ SPN230T06T262RGB : Tape&Reel ; Pb – Free ; Halogen - Free

ABSOLUTE MAXIMUM RATINGS

(TA=25°C Unless otherwise noted)

Parameter	Symbol	Typical	Unit	
Drain-Source Voltage	V _{DSS}	60	V	
Gate –Source Voltage	V _{GSS}	±20	V	
Continuous Drain Current(T _J =150°C)	I _D	TA=25°C	230	A
		TA=70°C	160	
Pulsed Drain Current	I _{DM}	500	A	
Avalanche Energy, Single Pulse @ L=1mH, TA=25°C	E _{AS}	350	mJ	
Power Dissipation @ TA=25°C	P _D	104	W	
Operating Junction Temperature	T _J	-55/150	°C	
Storage Temperature Range	T _{STG}	-55/150	°C	
Thermal Resistance-Junction to Case	R _{θJC}	1.2	°C/W	



SPN230T06

N-Channel Enhancement Mode MOSFET

ELECTRICAL CHARACTERISTICS

(TA=25°C Unless otherwise noted)

Parameter	Symbol	Conditions	Min.	Typ	Max.	Unit
Static						
Drain-Source Breakdown Voltage	$V_{(BR)DSS}$	$V_{GS}=0V, I_D=250\mu A$	60			V
Gate Threshold Voltage	$V_{GS(th)}$	$V_{DS}=V_{GS}, I_D=250\mu A$	2.0	2.8	4.0	
Gate Leakage Current	I_{GSS}	$V_{DS}=0V, V_{GS}=\pm 20V$			± 100	nA
Zero Gate Voltage Drain Current	I_{DSS}	$V_{DS}=60V, V_{GS}=0V$ $T_J=25^\circ C$			1	uA
		$V_{DS}=60V, V_{GS}=0V$ $T_J=100^\circ C$			100	
Drain-Source On-Resistance	$R_{DS(on)}$	$V_{GS}=10V, I_D=20A$		2.1	2.5	mΩ
Forward Transconductance	g_{fs}	$V_{DS}=5V, I_D=20A$		80		S
Gate Resistance	R_G	$V_{GS}=0V, V_{DS}=Open, f=1MHz$		0.7		Ω
Diode Forward Voltage	V_{SD}	$I_S=20A, V_{GS}=0V$		0.9	1.2	V
Dynamic						
Total Gate Charge	Q_g	$V_{DS}=30V, V_{GS}=10V$ $I_D=20A$		85		nC
Gate-Source Charge	Q_{gs}			24		
Gate-Drain Charge	Q_{gd}			14		
Input Capacitance	C_{iss}	$V_{DS}=30V, V_{GS}=0V$ $f=1MHz$		7070		pF
Output Capacitance	C_{oss}			2140		
Reverse Transfer Capacitance	C_{rss}			63		
Turn-On Time	$t_{d(on)}$	$V_{DD}=30V, V_{GS}=10V$ $I_D=20A, R_G=10\Omega$		36		nS
	t_r			62		
Turn-Off Time	$t_{d(off)}$			95		
	t_f			34		



SPN230T06

N-Channel Enhancement Mode MOSFET

TYPICAL CHARACTERISTICS

Fig 1. Typical Output Characteristics

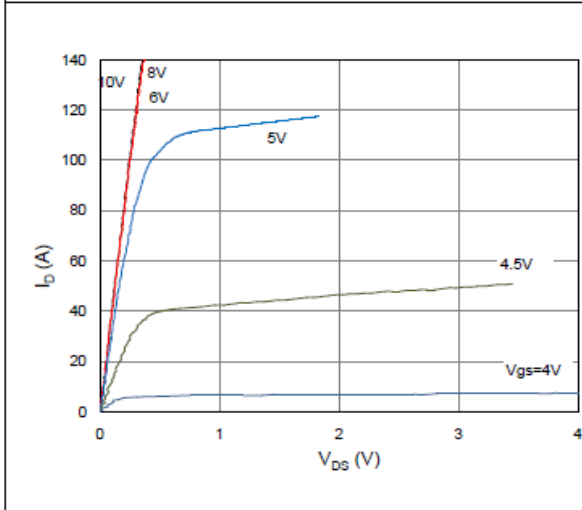

Figure 2. On-Resistance vs. Gate-Source Voltage

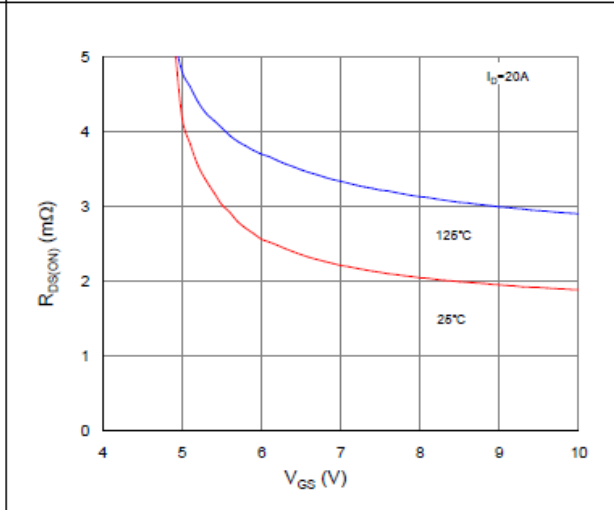

Figure 3. On-Resistance vs. Drain Current and Gate Voltage

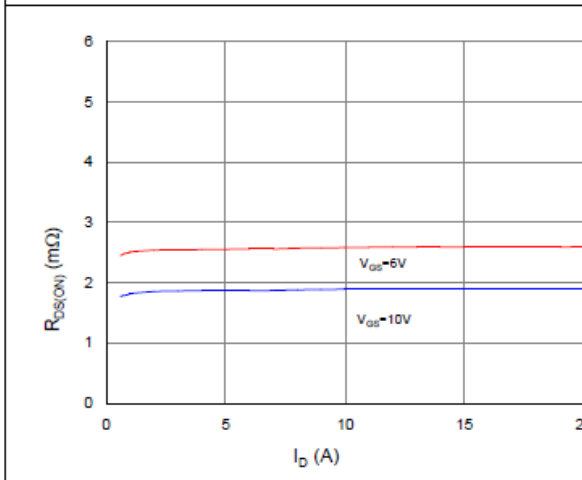

Figure 4. Normalized On-Resistance vs. Junction Temperature

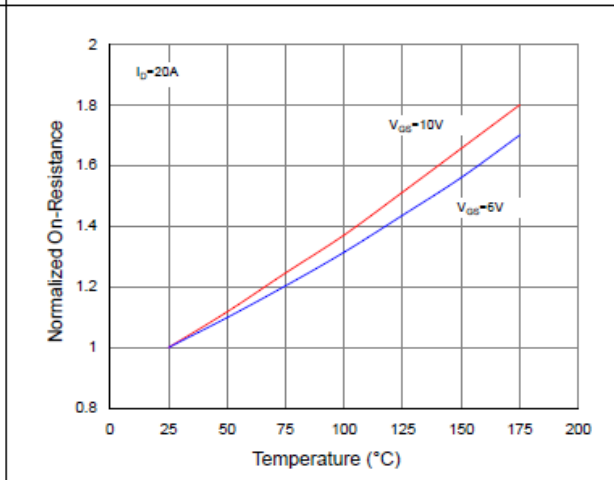

Figure 5. Typical Transfer Characteristics

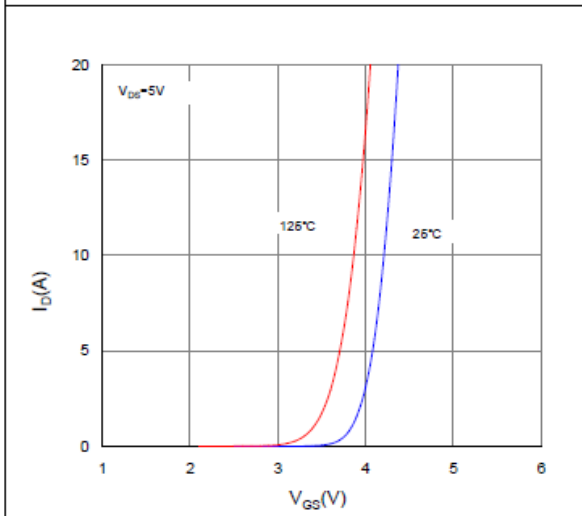
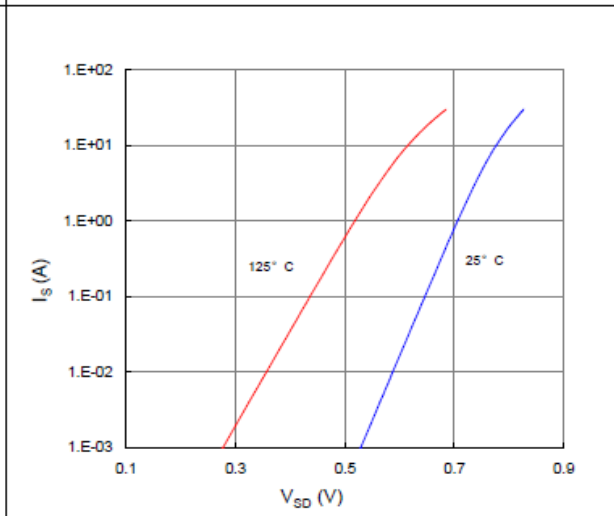

Figure 6. Typical Source-Drain Diode Forward Voltage





SPN230T06

N-Channel Enhancement Mode MOSFET

TYPICAL CHARACTERISTICS

Figure 7. Typical Gate-Charge vs. Gate-to-Source Voltage

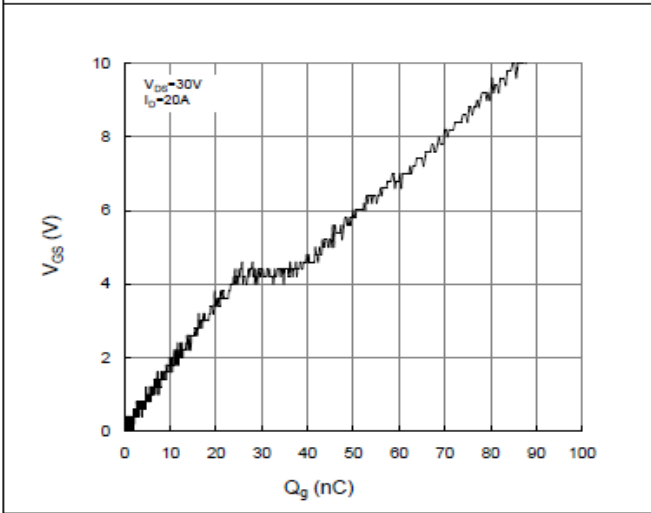

Figure 8. Typical Capacitance vs. Drain-to-Source Voltage

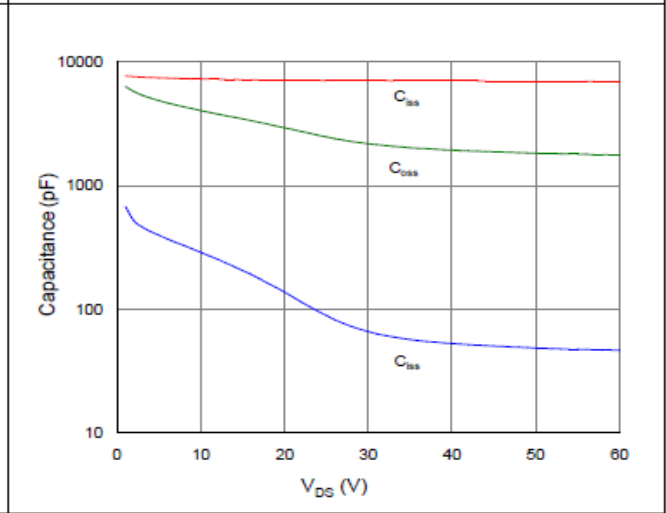

Figure 9. Maximum Safe Operating Area

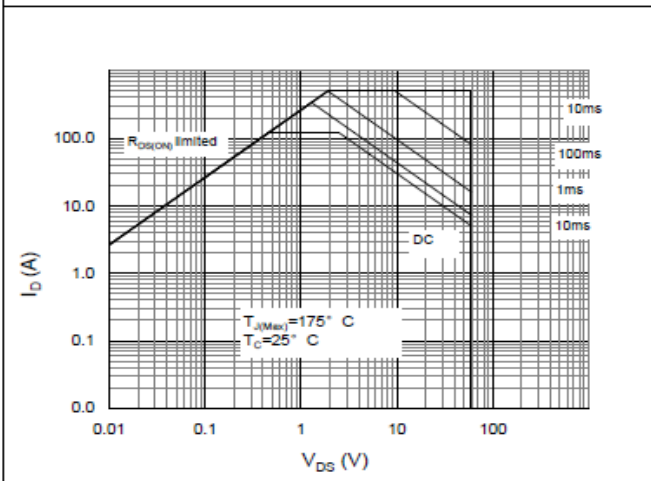

Figure 10. Maximum Drain Current vs. Case Temperature

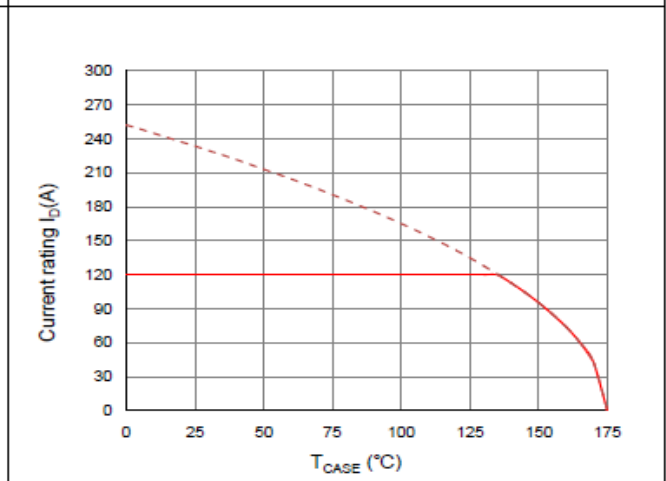
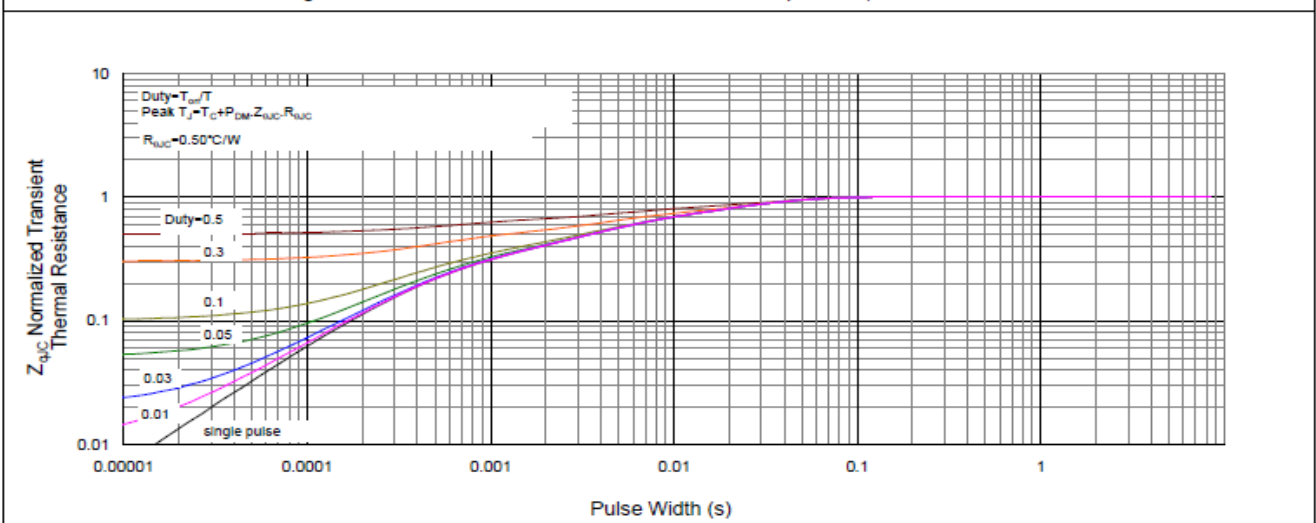

Figure 11. Normalized Maximum Transient Thermal Impedance, Junction-to-Case





SPN230T06

N-Channel Enhancement Mode MOSFET

TO-220-3L PACKAGE OUTLINE

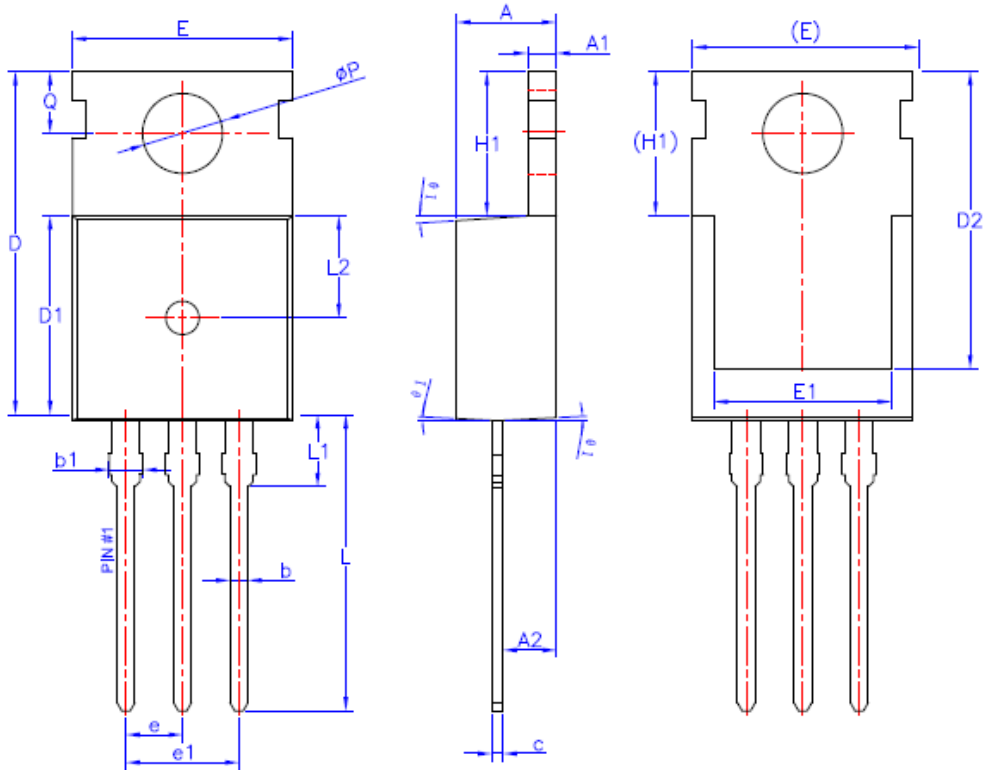

SYMBOL	MIN	NOM	MAX
A	4.40	4.50	4.60
A1	1.27	1.30	1.33
A2	2.30	2.40	2.50
b	0.70	0.60	0.90
b1	-	-	1.40
c	0.45	0.50	0.60
D	15.30	15.70	16.10
D1	9.10	9.20	9.30
D2	13.10	-	13.70
E	9.70	9.90	10.20
E1	7.80	8.00	8.20
e	2.54BSC		
e1	5.08BSC		
H1	6.30	6.50	6.70
L	12.78	13.08	13.38
L1	-	-	3.50
L2	4.6REF		
ϕP	3.55	3.60	3.65
Q	2.73	-	2.87
$\theta 1$	1°	3°	5°



SPN230T06

N-Channel Enhancement Mode MOSFET

TO-263-2L PACKAGE OUTLINE

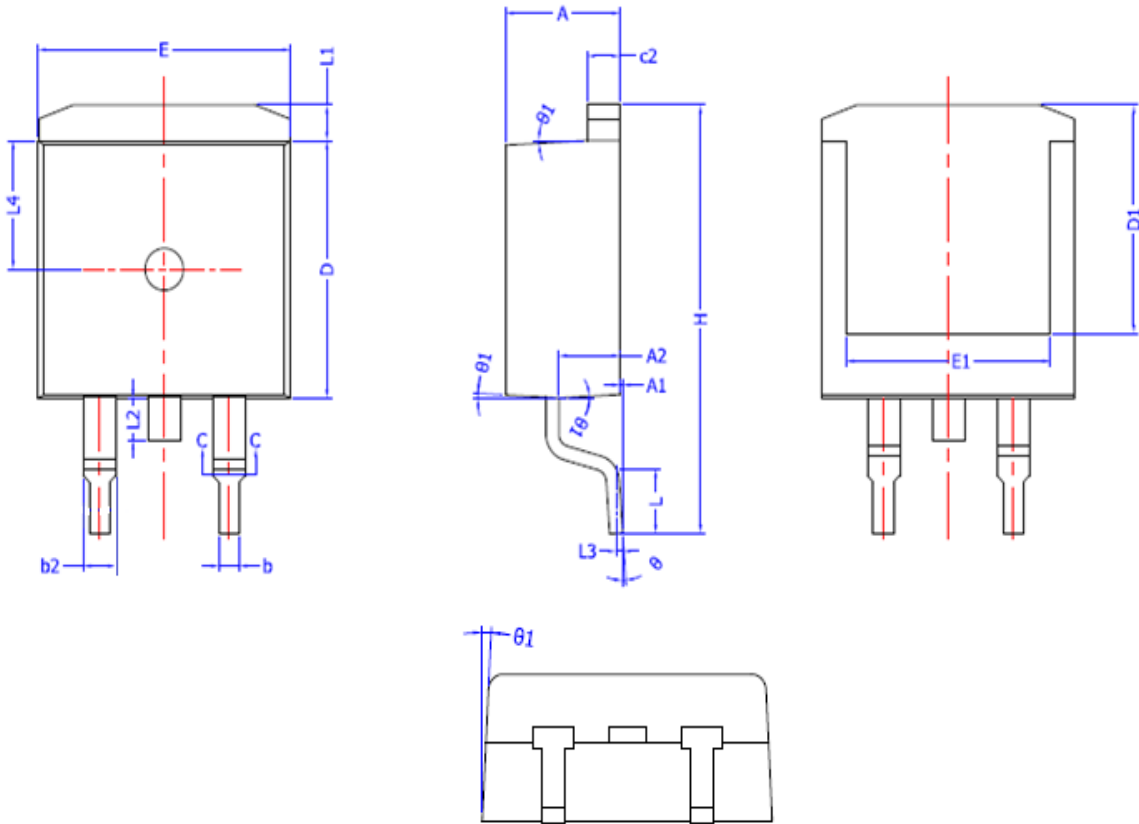

SYMBOL	MIN	NOM	MAX
A	4.40	4.50	4.60
A1	0.00	0.10	0.25
A2	2.20	2.40	2.60
b	0.71	-	0.91
b2	1.17	--	1.37
c	0.47	--	0.60
c2	1.25	1.30	1.35
D	9.10	9.20	9.30
D1	8.00	--	--
E	9.80	9.90	10.00
E1	7.80	--	--
e	2.54BSC		
H	14.90	15.30	15.70
L	2.00	2.30	2.60
L1	1.12	1.27	1.42
L2	--	--	1.75
L3	0.25BSC		
L4	4.60 REF		
θ	0°	--	8°
$\theta 1$	1°	3°	5°



SPN230T06

N-Channel Enhancement Mode MOSFET

Information provided is alleged to be exact and consistent. SYNC Power Corporation presumes no responsibility for the penalties of use of such information or for any violation of patents or other rights of third parties which may result from its use. No license is granted by allegation or otherwise under any patent or patent rights of SYNC Power Corporation. Conditions mentioned in this publication are subject to change without notice. This publication surpasses and replaces all information previously supplied. SYNC Power Corporation products are not authorized for use as critical components in life support devices or systems without express written approval of SYNC Power Corporation.

© The SYNC Power logo is a registered trademark of SYNC Power Corporation

© 2016 SYNC Power Corporation – Printed in Taiwan – All Rights Reserved

SYNC Power Corporation

7F-2, No.3-1, Park Street

NanKang District (NKSP), Taipei, Taiwan 115

Phone: 886-2-2655-8178

Fax: 886-2-2655-8468

© <http://www.syncpower.com>