



SPN5003

N-Channel Enhancement Mode MOSFET

DESCRIPTION

The SPN5003 is the N-Channel logic enhancement mode power field effect transistor which is produced with high voltage BiCMOS technology. This device is particularly suited for reducing the no load consumption in PC power, TV power and Adapter.

APPLICATIONS

- Desk PC Power Supply
- AC adapter
- LCD TC Power Supply
-

FEATURES

- ◆ 500V/10mA, $R_{DS(ON)}=250\Omega @ V_{GS}=10V$
- ◆ Reduce power consumption at no load for EPA/Climate Saver Application
- ◆ SOP-8 and DIP-8 package design

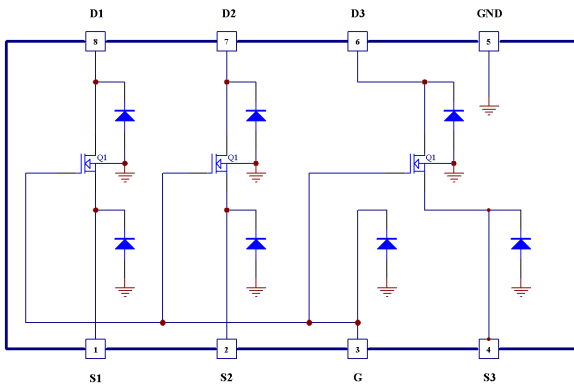

PIN CONFIGURATION

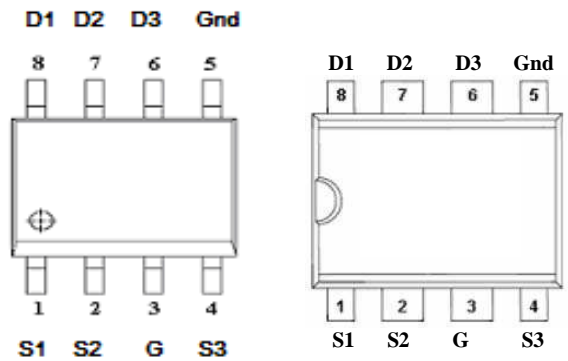

PART MARKING

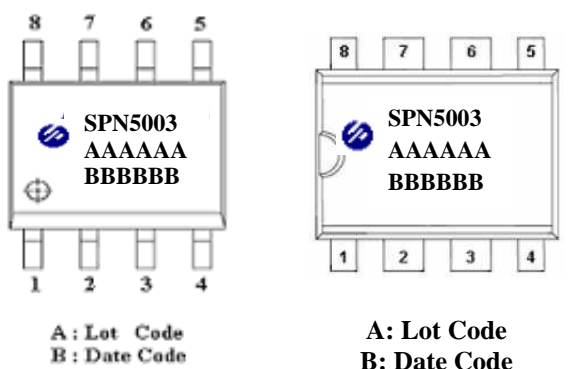



SPN5003

N-Channel Enhancement Mode MOSFET

PIN DESCRIPTION

Pin	Symbol	Description
1	S1	Source 1
2	S2	Source 2
3	G	Gate
4	S3	Source 3
5	Ground	Ground
6	D3	Drain 3
7	D2	Drain 2
8	D1	Drain 1

ORDERING INFORMATION

Part Number	Package	Part Marking
SPN5003S8RGB	SOP-8	SPN5003
SPN5003D8TGB	DIP-8	SPN5003

※ SPN5003S8RGB : Tape Reel ; Pb – Free ; Halogen - Free

※ SPN5003D8TGB : Tube ; Pb – Free ; Halogen - Free

ABSOLUTE MAXIMUM RATINGS

($T_A=25^{\circ}\text{C}$ Unless otherwise noted)

Parameter	Symbol	Typical	Unit	
Drain-Source Voltage	V_{DSS}	500	V	
Gate –Source Voltage	V_{GSS}	+20	V	
Continuous Drain Current($T_J=150^{\circ}\text{C}$)	I_D	$T_A=25^{\circ}\text{C}$	30	mA
		$T_A=70^{\circ}\text{C}$	20	
Pulsed Drain Current	I_{DM}	200	mA	
Power Dissipation	P_D	$T_A=25^{\circ}\text{C}$	1.3	W
		$T_A=70^{\circ}\text{C}$	1.0	
Operating Junction Temperature	T_J	150	$^{\circ}\text{C}$	
Storage Temperature Range	T_{STG}	-55/150	$^{\circ}\text{C}$	
Thermal Resistance-Junction to Ambient	$R_{\theta JA}$	80	$^{\circ}\text{C}/\text{W}$	



SPN5003

N-Channel Enhancement Mode MOSFET

ELECTRICAL CHARACTERISTICS

(TA=25°C Unless otherwise noted)

Parameter	Symbol	Conditions	Min.	Typ	Max.	Unit
Static						
Drain-Source Breakdown Voltage	$V_{(BR)DSS}$	$V_{GS}=0V, I_D=40\mu A$	500			V
Gate Threshold Voltage	$V_{GS(th)}$	$V_{DS}=V_{GS}, I_D=250\mu A$	0.75	1.3	2.25	
Gate Leakage Current	I_{GSS}	$V_{DS}=0V, V_{GS}=+20V$			20	μA
Zero Gate Voltage Drain Current	I_{DSS}	$V_{DS}=400V, V_{GS}=0V$			25	μA
On-State Drain Current	$I_{D(on)}$	$V_{DS} \geq 5V, V_{GS} = 10V$	25			mA
Drain-Source On-Resistance	$R_{DS(on)}$	$V_{GS} = 10V, I_D = 10mA$		160	250	Ω
		$V_{GS} = 4.5V, I_D = 10mA$		180	250	Ω
Diode Forward Voltage	V_{SD}	$I_S = 10mA, V_{GS} = 0V$		0.8	1.0	V
Dynamic						
Gate-Source Charge	Q_{gs}	$V_{DS}=50V, V_{GS}=10V$ $I_D = 25mA$		1		nC
Turn-On Time	$t_{d(on)}$	$V_{DD}=50V, R_L=2.7\Omega$ $V_{GEN}=5V, R_G=3\Omega$		20		nS
	t_r			16		
Turn-Off Time	$t_{d(off)}$			4		
	t_f			3.8		



SPN5003 N-Channel Enhancement Mode MOSFET

SOP-8 PACKAGE OUTLINE

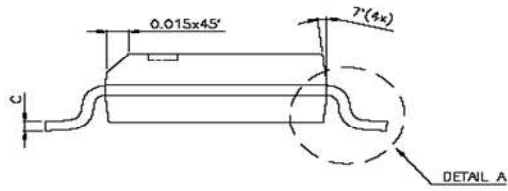
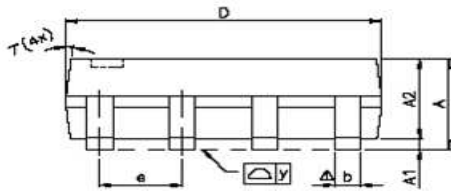
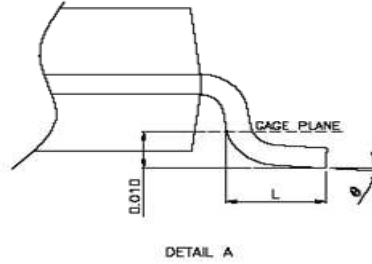
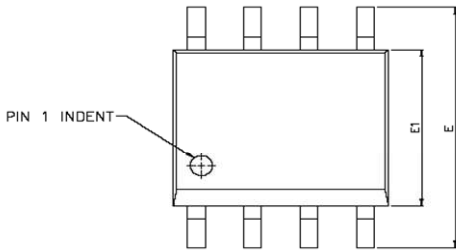

SYMBOLS	DIMENSIONS IN MILLIMETERS			DIMENSIONS IN INCHES		
	MIN	NOM	MAX	MIN	NOM	MAX
A	1.47	1.60	1.73	0.058	0.063	0.068
A1	0.10	—	0.25	0.004	—	0.010
A2	—	1.45	—	—	0.057	—
b	0.33	0.41	0.51	0.013	0.016	0.020
C	0.19	0.20	0.25	0.0075	0.008	0.0098
D	4.80	4.85	4.95	0.189	0.191	0.195
E	5.80	6.00	6.20	0.228	0.236	0.244
E1	3.80	3.90	4.00	0.150	0.154	0.157
e	—	1.27	—	—	0.050	—
L	0.38	0.71	1.27	0.015	0.028	0.050
Δ y	—	—	0.076	—	—	0.003
θ	0°	—	8°	0°	—	8°



SPN5003 N-Channel Enhancement Mode MOSFET

DIP-8P PACKAGE OUTLINE

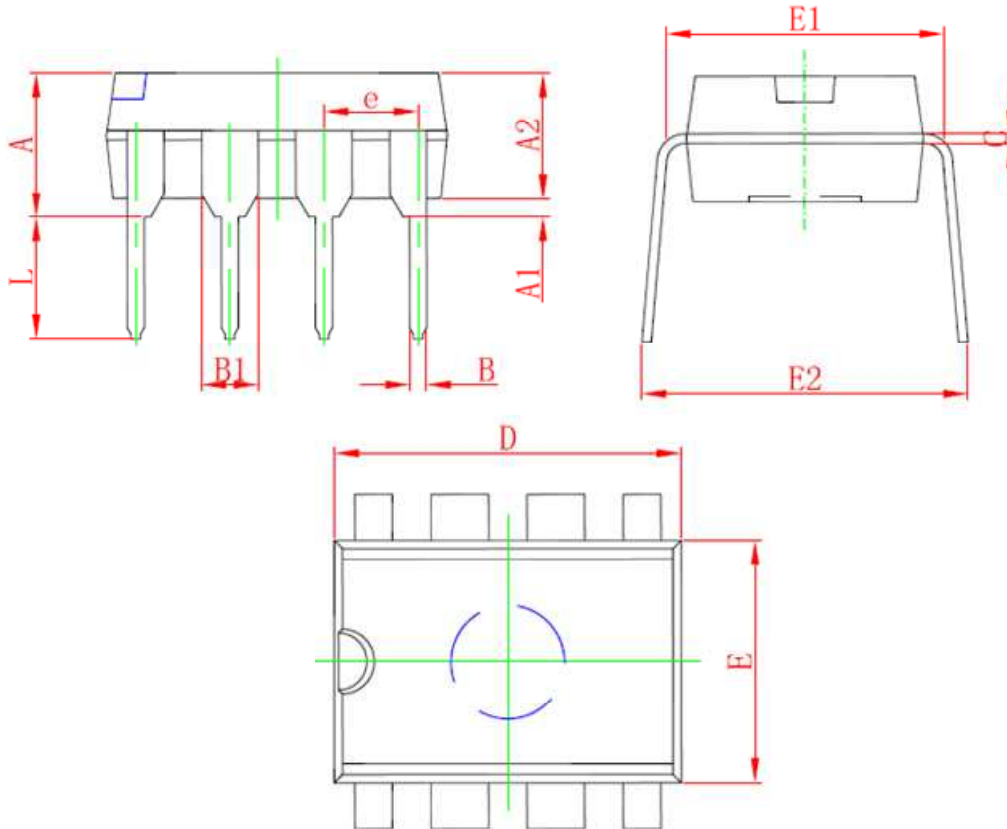

Symbol	Dimensions In Millimeters		Dimensions In Inches	
	Min	Max	Min	Max
A	3.710	4.310	0.146	0.170
A1	0.510		0.020	
A2	3.200	3.600	0.126	0.142
B	0.380	0.570	0.015	0.022
B1	1.524 (BSC)		0.060 (BSC)	
C	0.204	0.360	0.008	0.014
D	9.000	9.400	0.354	0.370
E	6.200	6.600	0.244	0.260
E1	7.320	7.920	0.288	0.312
e	2.540 (BSC)		0.100 (BSC)	
L	3.000	3.600	0.118	0.142
E2	8.400	9.000	0.331	0.354



SPN5003

N-Channel Enhancement Mode MOSFET

Information provided is alleged to be exact and consistent. SYNC Power Corporation presumes no responsibility for the penalties of use of such information or for any violation of patents or other rights of third parties which may result from its use. No license is granted by allegation or otherwise under any patent or patent rights of SYNC Power Corporation. Conditions mentioned in this publication are subject to change without notice. This publication surpasses and replaces all information previously supplied. SYNC Power Corporation products are not authorized for use as critical components in life support devices or systems without express written approval of SYNC Power Corporation.

©The SYNC Power logo is a registered trademark of SYNC Power Corporation

©2010 SYNC Power Corporation – Printed in Taiwan – All Rights Reserved

SYNC Power Corporation

7F-2, No.3-1, Park Street

NanKang District (NKSP), Taipei, Taiwan, 115, R.O.C

Phone: 886-2-2655-8178

Fax: 886-2-2655-8468

©<http://www.syncpower.com>